

**Durham Accessibility and Inclusivity
Design Requirements
DRAFT For Review with Region**

PURPOSE



Durham Accessibility and Inclusivity Requirements

April 8, 2022

Acknowledgements

November 2022

Re: Durham Accessibility Requirements

Dear reader/user of these Requirements

On behalf of the Region of Durham, we are pleased to present the 2022 Durham Accessibility and Inclusivity Requirements. The requirements presented in the manual are intended to apply to all newly constructed and/or renovated facilities owned, leased or operated by the member organizations of the Region of Durham. We would like to thank and recognize the contributions of:

- Members of the Durham Region Review Committees and Focus Groups, *any specific individuals that should be recognized within Durham Region*, but particularly the community participants who have taken the time to provide the Region of Durham with their input concerning these design requirements. The Corporation of the City of Markham and the City of Oshawa for their generous permission for permitting the adaptation of their Accessibility Design Guidelines, and the City of Mississauga for use as reference and resource materials for these Requirements.



MISSISSAUGA

- The staff of Purpose and DesignABLE Environments for their guidance and work in drafting the document.



Name/position of Durham Region Staff

Durham Accessibility and Inclusivity Requirements

April 8, 2022

Contents

| | |
|-----------------------------------------------|-----|
| 1.0 Introduction | 5 |
| 1.1 Mandate | 5 |
| 1.2 Understanding Disability..... | 6 |
| 1.3 Regulatory Framework | 7 |
| 1.4 Standard Organization and Use | 9 |
| 2.0 Exterior and Interior Elements | 13 |
| 2.1 Ground and Floor Surfaces | 13 |
| 2.2 Ramps..... | 16 |
| 2.3 Stairs | 21 |
| 2.4 Guards and Handrails | 25 |
| 2.5 Overhanging and Protruding Objects | 27 |
| 2.6 Rest Areas | 29 |
| 2.7 Tactile Walking Surface Indicators | 31 |
| 2.8 Drinking Fountains | 33 |
| 2.9 Public Telephones..... | 36 |
| 2.10 Seating, Tables and Work Surfaces | 39 |
| 3.0 Exterior Elements | 42 |
| 3.1 Parking..... | 42 |
| 3.2 EV Charging Parking Spaces | 47 |
| 3.3 Passenger Loading Zones | 50 |
| 3.4 Exterior Path of Travel | 53 |
| 3.5 Curb Ramps and Depressed Curbs | 56 |
| 4.0 Interior Environments..... | 60 |
| 4.1 Entrances..... | 60 |
| 4.2 Doors and Doorways..... | 62 |
| 4.3 Interior Accessible Routes | 73 |
| 4.4 Elevating Devices | 77 |
| 4.5 Washrooms | 80 |
| 4.6 Showers | 93 |
| 5.0 Systems, Controls and Communications..... | 97 |
| 5.1 Controls and Operating Mechanisms..... | 97 |
| 5.2 Assistive Listening Systems | 100 |
| 5.3 Public Address Systems..... | 102 |
| 5.4 Acoustics | 103 |

Durham Accessibility and Inclusivity Requirements

April 8, 2022

| | |
|------------------------------------------------|-----|
| 5.5 Security Systems | 104 |
| 5.6 Fire and Life Safety Systems | 106 |
| 5.7 Lighting | 109 |
| 5.8 Signage and Wayfinding | 111 |
| 5.9 Windows | 117 |
| 6.0 Special Facilities and Spaces..... | 119 |
| 6.1 Assembly Areas | 119 |
| 6.2 Meeting and Multi-Purpose Rooms | 122 |
| 6.3 Cafeteria and Dining Facilities | 124 |
| 6.4 Kitchens and Kitchenettes | 126 |
| 6.5 Libraries | 134 |
| 6.6 Recreational and Community Facilities..... | 137 |
| 6.7 Change Rooms..... | 140 |
| 6.8 Balconies and Terraces..... | 143 |
| 6.9 Service Counters..... | 144 |
| 6.10 Waiting and Queuing Areas | 147 |
| 6.11 Visitability – Housing..... | 150 |
| 6.12 Outdoor Public Use Eating Areas | 152 |
| 6.13 Inclusive Play Spaces | 154 |
| 6.14 Multi-Faith Rooms..... | 157 |
| 7.0 Appendices | 159 |
| 7.1 Glossary | 159 |
| 7.2 Feedback Form | 167 |

Durham Accessibility and Inclusivity Requirements

April 8, 2022

1.0 Introduction

1.1 Mandate

The Region of Durham (Region) intends to be a leader in developing accessible environments for all, embracing the principles of “universal design”, defined as the:

“design of products and environments to be usable by all people, to the greatest extent possible, without the need for adaptation or specialized design.”

Source: North Carolina State University, Center for Universal Design, 1997

The Durham Accessibility and Inclusivity Requirements (DAIR) were developed with recognition of the following:

- Diversity: Encourages the inclusion and integration of diverse communities, appreciating differences, while promoting a common goal to make the Region a more accessible place to live, work, play and learn;
- Barrier Removal: Preventing and removing obstructions that create exclusion;
- Provincial Directions: Accessibility standards in the areas of customer service, information and communication, employment, transportation and the built environment, developed under the Accessibility for Ontarians with Disabilities Act, 2005 (AODA) initiative; and
- Changing Demographics: People with varying types of disabilities comprise a significant proportion of the population. The proportion of seniors within the Canadian population is also increasing rapidly and for some people, acquiring a disability may also increase with age. Currently, people with disabilities represent approximately one in seven Ontarians. Due primarily to aging, one in every five Ontarians is expected to have a disability within 20 years.

With accessibility requirements and related best practices continually evolving, particularly in light of recent changes to Provincial legislation, update of the Durham Accessibility and Inclusivity Design Requirements (DAIR) will be an ongoing process. These requirements are a “living document”, evolving over time to meet best practices, and future changes that may be related to the Ontario Building Code (OBC), Canadian Standards Association (CSA) and the Accessibility for Ontarians with Disabilities Act, 2005 (AODA) updates.

During the planning, design and construction of accessible spaces and buildings, a range of opportunities exist to optimize independent access for people with disabilities and to improve accessibility for all users. **The purpose of the Region’s Accessibility and Inclusivity Design Requirements is to set out the conditions for meeting the Region’s performance standards with respect to accessibility and inclusivity in its facilities.**

Finally, the Region is committed to identifying, removing and preventing barriers, but also intends to demonstrate leadership in an effort to encourage the private sector to follow the Region’s designs related to both existing and new facilities.

Please note that these requirements use person first language (PFL).

Durham Accessibility and Inclusivity Requirements

April 8, 2022

1.2 Understanding Disability

Using a Cross-Disability Perspective

Knowledge of the basic characteristics of different disabilities and the resulting barriers is critical towards understanding individual needs and how to address them when designing the built environment. Common types of disabilities are identified within these Requirements to assist with understanding how users with disabilities interact with elements of the built environment. A list of key types of disabilities include but are not limited to:

- Auditory Disabilities
- Intellectual Disabilities
- Physical Disabilities
- Developmental Disabilities
- Visual Disabilities
- Learning Disabilities
- Mental Health Disabilities

The intent is to recognize and understand that everyone will experience variations in abilities throughout their lifespan, or ‘universal’ abilities. This approach considers no distinction between people with or without disabilities, focusing on identifying what is usable and safe for everyone in the community. The focus is also on extending the ideals of accessible design to routinely under-served populations, like people of short stature, seniors, pregnant women, parents with children in strollers, people who speak different languages and others.

The universal design philosophy is structured around the seven design principles listed below.

Principles of Universal Design

| | | |
|----------|--------------------------------------------|------------------------------------------------------------------------------------------------------------------------------------------|
| 1 | Equitable Use | The design is useful and marketable to people with diverse abilities. |
| 2 | Flexibility in Use | The design accommodates a wide range of individual preferences and abilities. |
| 3 | Simple and Intuitive | Use of the design is easy to understand, regardless of the user's experience, knowledge, language skills or current concentration level. |
| 4 | Perceptible Information | The design communicates necessary information effectively to the user, regardless of ambient conditions or the user's sensory ability. |
| 5 | Tolerance for Error | The design minimizes hazards and the adverse consequences of accidental or unintended actions. |
| 6 | Low Physical Effort | The design can be used efficiently and comfortably and with a minimum of fatigue. |
| 7 | Size and Space for Approach and Use | Appropriate size and space is provided for approach, reach, manipulation and use regardless of user's body size, posture or mobility. |

Source: North Carolina State University, Centre for Universal Design, 1997.

Durham Accessibility and Inclusivity Requirements

April 8, 2022

1.3 Regulatory Framework

The development of the Durham Accessibility and Inclusivity Design Requirements (DAIR) is driven by the regulatory environment and important provincial accessibility legislation and related requirements, which also supports the Region's position and initiative to be proactive and a leader in developing inclusive communities.

While the DAIR have been developed to assist with compliance with relevant legislation and related requirements, users are cautioned that the DAIR by no means attempts to duplicate all the details of those references. Users must be familiar with the relevant legislation that affects a particular project or situation to ensure compliance.

For more information on Durham Region's Accessibility Advisory Committee, refer to the Region's website at www.durham.ca/accessibility.

The framework from which the DAIR draws is summarized as follows:

1.3.1 The Ontarians with Disabilities Act, (ODA) 2001

The purpose of the ODA is to improve opportunities for people with disabilities and to provide for their involvement in the identification, removal and prevention of barriers.

Overall, the ODA does not expect municipalities to remove every existing barrier immediately, allowing for the removal of barriers to accessibility over time. The Regulations provide municipalities with flexibility to identify their own priorities and to decide on what level of detail they will include in their annual accessibility plans. This is based on the recognition and assumption that accessibility plans must be developed on sound planning principles, with issues addressed according to priorities and needs identified during the public consultation process.

1.3.2 The Accessibility for Ontarians with Disabilities Act (AODA), 2005

The AODA benefits all Ontarians by developing, implementing and enforcing accessibility standards in order to achieve accessibility for Ontarians with disabilities with respect to goods, services, facilities, accommodation, employment, buildings, structures and premises.

Under the AODA, the Council of every municipality having a population of not less than 10,000 is required to establish and/or maintain an Accessibility Advisory Committee (AAC). The committee advises Council about the requirements and implementation of accessibility standards and the preparation of accessibility reports; reviews in a timely manner the site plans and drawings described in section 41 of the Planning Act that the committee selects, and performs other functions that are outlined in the regulations to the AODA. Council is required to seek advice from the committee on accessibility for people with disabilities for the following:

- to a building, structure or premises,
- in whole or in part, that Council purchases, constructs, significantly renovates, enters into a lease or that a person provides as municipal capital facilities.

For more information about the Accessibility for Ontarians with Disabilities Act, visit:

<https://www.ontario.ca/laws/regulation/110191>

1.3.3 Ontario Regulation 191/11 Integrated Accessibility Standards Regulation (IASR)

The IASR, a regulation to the AODA, establishes the accessibility standards for information and communication, employment, transportation, design of public spaces and customer service. The requirements of the standards set out in the IASR are not a replacement or substitution for the requirements established under the Human Rights Code nor do the standards limit any obligations owed to people with disabilities under any other legislation.

Under the IASR, public sector organizations are required to establish, implement, maintain and document a multi-year accessibility plan, which outlines the strategy to be implemented to prevent and remove barriers and meet the requirements of the Regulation. Design of public

Durham Accessibility and Inclusivity Requirements

April 8, 2022

spaces requirements apply to public spaces that are newly constructed or redeveloped as outlined in the IASR.

Municipalities are also required to establish, review and update their accessibility plans in consultation with people with disabilities and their accessibility advisory committees as outlined in the AODA.

For more information on provincial legislation visit the Ministry of Economic Development, Employment & Infrastructure at:

www.mcass.gov.on.ca/en/mcass/programs/accessibility

1.3.4 The Human Rights Code

The Human Rights Code ('the Code') protects people from discrimination and harassment in five specific areas: 1) goods, services and facilities, 2) accommodation/ housing, 3) contracts, 4) employment and 5) membership in trade or vocational associations. Under the Code, every person has a right to equal treatment with respect to services, goods, facilities, employment, housing and membership in associations and trade unions, without discrimination and harassment because of disability, race, ancestry, place of origin, colour, ethnic origin, citizenship, creed, sex, sexual orientation, gender identity, gender expression, age, marital status and family status.

Employers, landlords, service providers and others have a duty to consider the needs of people with disabilities. This can include ways to apply the principles of inclusive or universal design for the construction or renovation of buildings and facilities, as well as their application to related processes, programs and services. If systems, facilities or other elements of the built environment or people's attitudes create discriminatory barriers, then they must be removed or changed. Where it is impossible to remove these barriers without undue hardship, then accommodations must be made so that people with disabilities can participate fully.

1.3.5 The Ontario Building Code Act, 1992 (OBC) as amended

Accessibility amendments to Ontario's Building Code came into force on January 1, 2015. The accessibility requirements, or "barrier-free design" requirements as they are referred to in the OBC (Section 3.8), are a minimum standard for buildings. The requirements of the OBC specifically related to accessibility can be summarized as follows:

- applies to most new construction and extensive renovation; and
- amended requirements cover a range of areas, such as parking, entrances, elevators, washrooms, barrier-free access, ramps, stairs, signs and exits.

1.3.6 Canadian Standards Association "Accessible Design for the Built Environment" (CSA B651-18)

Currently the Canadian Standards Association's "Accessible Design for the Built Environment" (CSA B651-18) is recognized as a voluntary national built environment standard for Canada. The C.S.A. B651-18 requirements are considered more comprehensive than the OBC however, there are limitations with respect to signage and wayfinding accessibility requirements.

Overall, the Durham Accessibility and Inclusivity Design Requirements go above and beyond the minimum requirements of the OBC and the voluntary CSA B651-18, and represent a "best practice" approach to providing accessible design.

1.3.7 The Ontario Planning Act

The Planning Act sets out the framework for land use planning in Ontario and describes how land uses may be controlled and who may control them. The Planning Act is designed to:

- promote sustainable economic development in a healthy natural environment within a provincial policy framework;
- provide for a land use planning system led by provincial policy;

Durham Accessibility and Inclusivity Requirements

April 8, 2022

- integrate matters of provincial interest into provincial and municipal planning decisions by requiring that all decisions shall be consistent with the Provincial Policy Statement when decision-makers exercise planning authority or provide advice on planning matters;
- provide for planning processes that are fair by making them open, accessible, timely and efficient;
- encourage co-operation and coordination among various interests; and
- recognize the decision-making authority and accountability of municipal councils in Planning.

The Provincial Policy Statement (P.P.S., 2014) of the Planning Act identifies the importance of healthy, livable and safe communities that are sustained by improving accessibility for people with disabilities and the elderly by removing and/or preventing land use barriers which restrict their full participation in society.

Provisions in the Planning Act enable municipalities to provide for accessibility through their planning and development decisions.

1.3.8 Other References

Several other key references were consulted in the creation and revision of the DAIR including:

- Canadian National Institute for the Blind (CNIB). (2009). Clearing Our Path Universal design recommendations for people with vision loss.
- Global Alliance on Accessible Technologies and Environments (GAATES). (2014). Illustrated Technical Guide to the Accessibility Standard for the Design of Public Spaces.
- Parks and Recreation Ontario. (2014). Pathways to Recreation: Learning about Ontario's Accessibility Standard for the Design of Public Spaces Guidebook.
- AccessON (April 2014). A Guide to the Integrated Accessibility Standards Regulation.
- International Organization for Standardization (I.S.O.). (2011). I.S.O.21542:2011 Accessibility and Usability of the Built Environment.

1.4 Requirements Organization and Use

These Requirements were organized to provide accessibility criteria in the following sections, in order to group and identify issues that are related. These sections are identified as follows:

1.0 Introduction

2.0 Common Elements: Exterior and Interior

3.0 Exterior Environments

4.0 Interior Environments

5.0 Systems, Controls and Communication

6.0 Special Facilities and Spaces

7.0 Appendices

These Sections are further divided into additional subsections that refer to specific site or facility elements. Each section begins with

- a) Rationale, which provides a brief overview and reasoning for inclusion and implementation of the various design requirements within the section, and,
- b) Application which identifies and assists with implementation and how each section relates or applies to the built environment, element or feature.

Durham Accessibility and Inclusivity Requirements

April 8, 2022

1.4.1 Scope and Application

The accessible design criteria provided in the DAIR aim to make Region-owned or leased spaces, buildings, infrastructure and elements accessible as possible to Durham residents, employees and visitors, as part of any new construction or redevelopment activities. The intent is for the Region to clearly identify the accessibility criteria and features included in the procurement of its facilities and to demonstrate proactive steps towards making its facilities and sites accessible.

The Region of Durham recognizes that addressing accessibility issues as early as possible in the planning and design phases of new construction and redevelopment projects is the most practical and cost-effective way to ensure accessible and inclusive environments.

The DAIR are:

- mandatory for all new construction and redevelopment of existing spaces and facilities, owned, leased or operated by the Region of Durham;
- intended to be applied to the greatest extent possible for retrofit, alternations or additions to existing spaces and facilities owned, leased or operated by the Region of Durham;
- encouraged to be implemented by other sectors and organizations within the Region of Durham; and
- recognized as addressing the needs of diverse users, with or without disabilities, to ensure inclusive environments for all.

The DAIR are not applicable to the following spaces and areas:

- equipment service rooms or spaces;
- elevator machine rooms;
- janitor rooms;
- crawl spaces; and
- other similar areas identified in the Ontario Building Code.

Although the design criteria contained in these Requirements may differ from the requirements of the AODA, Ontario Building Code and the Canadian Standards Association's "Accessible Design for the Built Environment (C.S.A. B651-12), the intent is that AODA, and OBC requirements are used as the baseline minimum requirements that are to be applied. The DAIR reflect an optimum level of accessibility for the design of the built environment, as the Requirements are intended to meet or go beyond the requirements of the AODA, OBC and CSA.

By making the applicable to planning, design, construction and development activities, Durham will demonstrate its commitment to proactive measures to eliminate and prevent barriers faced by people with disabilities.

1.4.2 Existing Barriers and Conditions

Barrier removal for existing Region spaces, infrastructure, facilities and elements is conducted annually through a list of priorities established in the Durham Accessibility Plan. The Region intends to implement the DAIR to the greatest extent possible for renovations and alterations to facilities, sites and elements of the built environment.

Designers will be required to coordinate with the Region on including barrier removal from the respective facility in the scope of the project.

Consultation with the Region's Project Manager should be done where there are questions or options.

Durham Accessibility and Inclusivity Requirements

April 8, 2022

1.4.3 Implementation Alternatives

Consistent with the policies of national and international accessibility standards, the information within the DAIR are not intended to prevent the use of other designs, products or technologies as alternatives to those identified. This assumes that the implementation of these alternatives will result in an equivalent or an increased level of accessibility, meeting the principles of universal accessibility.

Implementation alternatives will be evaluated on a project-by-project basis by Region staff, in collaboration and consultation with all relevant stakeholders, including the Durham Accessibility Advisory Committee, as required.

It is the intent of the Region to review the DAIR every five (5) years to ensure the highest level of accessibility is achieved and to ensure the DAIR reflect any future changes to the legislation.

Consultation with the Region's Project Manager should be done where there are questions or options.

1.4.4 Exceptions

For Region facilities when exceptions to the Accessibility and Inclusion Design Requirements are approved by the appropriate Region of Durham authority, the exceptions must be documented and provided in writing to the Region's Project Manager.

Financial constraints are not typically regarded as an acceptable rationale for an exception to be approved. There are some exceptions allowed by the IASR which are specifically related to heritage, historic, or environmental effects. The IASR also notes exceptions where it is not practicable to comply with those requirements because existing physical or site constraints prohibit modification or addition of elements, spaces or features - examples are noted within the individual subsections of the IASR.

1.4.5 Dimensions

Dimensions that are not marked as "maximum" or "minimum" are absolute, unless otherwise indicated. All dimensions for construction purposes are subject to conventional industry tolerances.

1.4.6 Definitions

Definitions for key words are provided in Section 7.1 "Glossary".

1.4.7 Special Note - "High Tonal Contrast"

Users of these Requirements will note the consistent use of the term "high tonal contrast". Tonal contrast refers to the difference in colour and brightness between one surface or element and its adjacent surface. Effective tonal contrast can be used to locate a particular feature, for example using a different colour and / or brightness for a handrail compared to the surface around the handrail.

In order to provide an effective differentiation between accessibility features and their surrounding surfaces, these Requirements call for the use of "high tonal contrast" as opposed to simply "tonal contrast" for many elements. "High" refers to the requirement to provide a very different colour and / or brightness level. For example, high tonal contrast can be achieved using dark brown / white or dark blue / white, compared to poor tonal contrast of yellow / grey or light blue / white.

More guidance on tonal contrast, and the best practice of providing a colour and brightness contrast of 70% or more can be found in:

- Canadian National Institute for the Blind (CNIB). (2009). Clearing Our Path-Universal design recommendations for people with vision loss.
- Global Alliance on Accessible Technologies and Environments (GAATES). (2014). Illustrated Technical Guide to the Accessibility Standard for the Design of Public Spaces.

Durham Accessibility and Inclusivity Requirements

April 8, 2022

1.4.8 Feedback Form

The Region of Durham recognizes that accessibility best practices continue to evolve and change over time, with the expectation that these Requirements are recognized as a “living document” and will be updated on a regular basis. A feedback form is provided in Section 7.2, for any recommendations on how to improve this document or to provide new information.

Durham Accessibility and Inclusivity Requirements

April 8, 2022

2.0 Exterior and Interior Elements

2.1 Ground and Floor Surfaces

Rationale

Design decisions related to ground and floor surfaces will influence every person who enters the property and the building. Irregular surfaces, such as cobblestones or pea-gravel finished concrete, are difficult for both walking and maneuvering of mobility devices. These surfaces can also create unpleasant and damaging vibration for wheeled mobility aids users. Slippery surfaces are hazardous to all individuals and especially hazardous for seniors and others who may not be sure-footed. Hard floor surfaces, such as marble or terrazzo may amplify footsteps and add another level of noise for people who are Deaf, deafened or hard of hearing.

The use of pavers should be carefully considered as they may heave or settle due to weather conditions and can become potential tripping hazards. If pavers are to be used, provide controls to prevent any potential heaving due to frost and minimize the number of joints. Pavers may be used as accent banding to delineate the accessible route.

Glare from polished floor surfaces can be uncomfortable for all users and can be a particular obstacle for those who are blind or have vision loss by obscuring important orientation and safety features. Pronounced colour contrast between walls and floor finishes may be helpful for those who are blind or have vision loss, as are changes in colour/texture where a change in level or function occurs.

Patterned floors should be avoided, as they can create visual confusion and can be misinterpreted as level changes by people with vision loss.

Tonal contrasted floor mats can provide textural and visual cues for people with vision loss. They can be used to indicate doorways or circulation intersection. Thick pile carpeting makes pushing a wheelchair very difficult. Small and uneven changes in floor level represent a further barrier to using a wheelchair but also present a tripping hazard to ambulatory people.

Openings in any ground or floor surface such as grates or grilles can catch canes or wheelchair wheels and can become a potential tripping hazard.

Application

This section applies to ground and floor surfaces throughout interior and exterior environments including, but not limited to floor areas, paths of travel, ramps, landings and stair surfaces. The type of materials and finishes used for ground and floor surfaces are essential in determining accessibility.

2.1.1 Surfaces

Ensure all ground and floor surfaces in interior and exterior environments:

- a. are firm, stable and slip-resistant;
- b. have a matte finish to minimize glare;
- c. are well-drained at locations where water or other liquid might be expected such as exterior locations, or washrooms;
- d. have saw cut joints between surfaces no wider than 5 mm (Figure 1); and
- e. where ground and floor surfaces have a change in level:
 - i. no bevel is required (e.g. vertical change permitted), where the change in level is less than 6 mm;
 - ii. provide a beveled slope of 1:2 (maximum - the ratio rise to run), where the change in level is between 6 and 13 mm;
 - iii. provide a slope, ramp or curb ramp, where the change in level is greater than 13 mm; and

Durham Accessibility and Inclusivity Requirements

April 8, 2022

iv. for exterior ground surfaces, refer to Section 3.3 Exterior Paths of Travel for additional details.

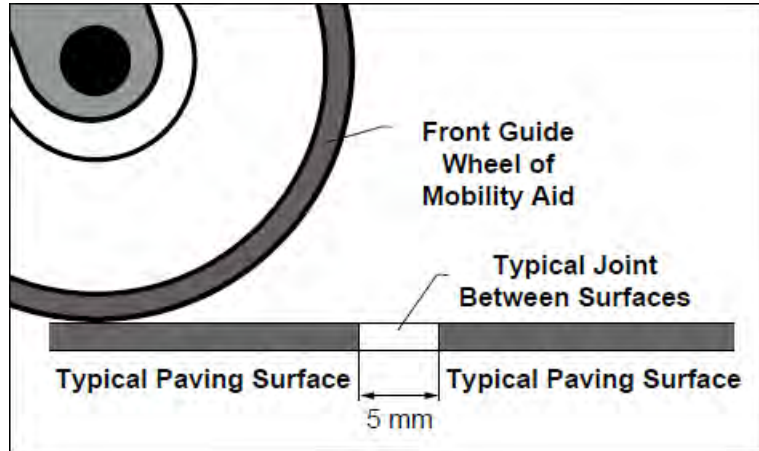

Figure 1: Joints Between Surfaces - Section View

2.1.2 Carpets

Where carpeting is used:

- a. ensure it is securely fastened;
- b. ensure combined carpet and pad height does not exceed 13 mm;
- c. ensure any cushion, under padding or backing is firm to reduce rolling resistance for wheeled mobility aids; and
- d. ensure it is a low level loop or level cut / uncut pile.

2.1.3 Floor Mats

Where floor mats are used:

- a. ensure they are securely fixed or placed in a depression that is level with surrounding floor area;
- b. ensure maximum mat height of 13 mm with beveled edges; and
- c. provide high tonal contrast between floor mats and surrounding surfaces.

2.1.4 Gratings and Covers

Openings can include sewer catch basin covers or drainage grates, utility covers and tree grates. Avoid use of any grate, opening or cover along accessible routes, especially high traffic areas in order to prevent any potential tripping hazards. Where there are any openings along the path of travel, or where gratings or other covers are required in both interior and exterior environments:

- a. ensure openings do not allow passage of an object that has a diameter greater than 13 mm (Figure 2a & b); and
- b. ensure that elongated openings are oriented perpendicular to the pedestrian path of travel.

Durham Accessibility and Inclusivity Requirements

April 8, 2022

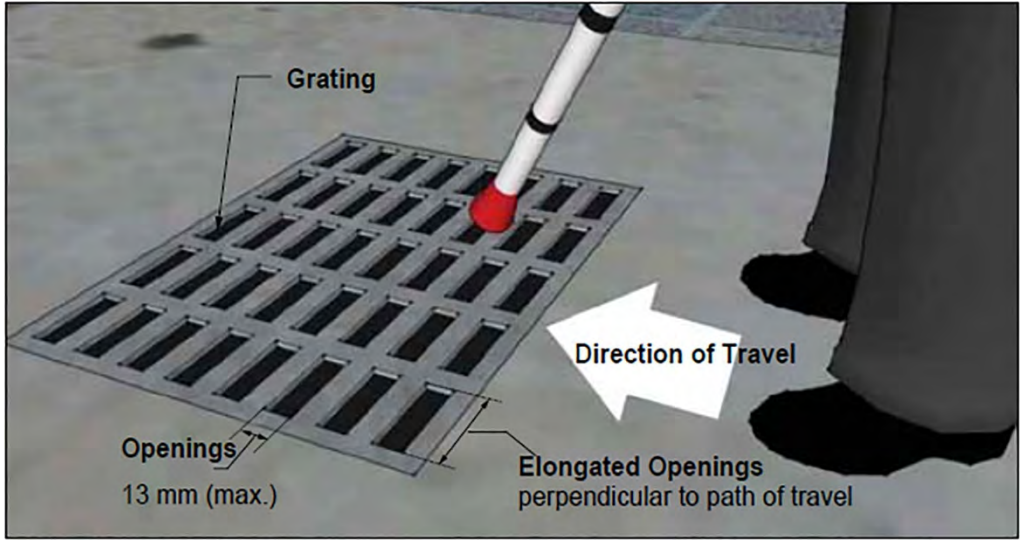

Figure 2a: Grating Opening

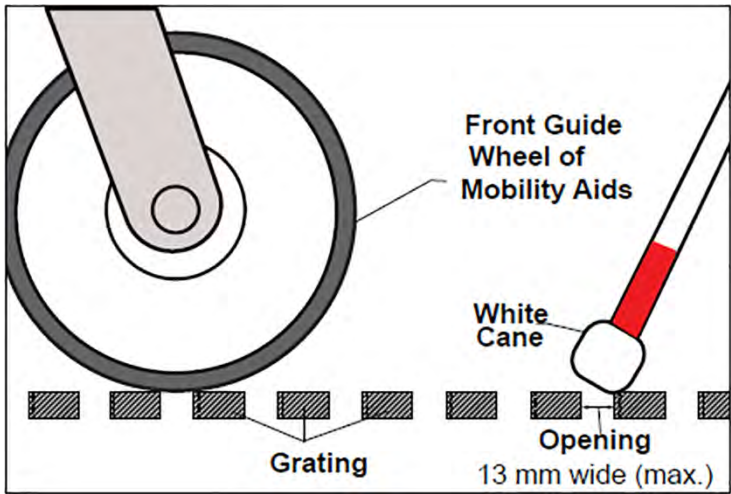

Figure 2b: Gratings – Section View

Durham Accessibility and Inclusivity Requirements

April 8, 2022

2.2 Ramps

Rationale

Traditionally, ramps have been synonymous with wheelchair accessibility. However, ramps can be problematic in providing accessibility, and it is preferred to avoid ramps in new construction where alternate universal design solutions are possible. Ramps can be difficult and dangerous to negotiate. Also, the physical space required for ramps makes them cumbersome to integrate into a facility. However, where a change in level already exists or cannot be avoided, a properly designed ramp can provide access for those using wheelchairs or scooters, people with mobility issues, and people pushing strollers or other wheeled items.

The design of the ramp is critical to its usefulness and safety. A steeply inclined ramp is difficult to ascend when using a wheelchair and can increase the risk of the wheelchair tipping backwards. Descending a steep ramp can also be hazardous. Any cross slope will further increase the effort required to negotiate the ramp. Manoeuvring space at the top and bottom are also important factors in a ramp's usability. Level areas at points along a long ramp enable an individual to rest.

Textured surfaces, edge protection and handrails all provide important safety features. Heated surfaces are recommended to address the safety concerns associated with snow and ice.

Application

This section applies to ramps provided as part of an accessible route within exterior or interior environments.

Additionally, refer to the Ontario Building Code (OBC) and Integrated Accessibility Standards Regulation (IASR) for ramp requirements.

2.2.1 Design Features

- a. provide a clear width of 1100 mm (minimum) between handrails;
- b. where space is available, a ramp surface of up to 1500 mm wide is preferred to allow space for a person with a companion or guide dog;
- c. ensure individual ramp sections are no longer than 9000 mm (Figure 3);
- d. provide landings:
 - i. at top and bottom of ramp;
 - ii. where there is any directional change; and
 - iii. between each ramp section where overall length of ramp exceeds 9000 mm (Figure 5);
- e. provide lighting in accordance with Section 5.7 Lighting requirements, as applicable;
- f. provide handrails on both sides of the ramp (Figure 8); and
- g. provide a wall or guard on both sides of the ramp (Figure 9).

Exterior ramp and landing surfaces should be heated to prevent snow and ice accumulation during winter conditions.

2.2.1.1 Running Slope

- a. ensure maximum gradient of 1:15 (6.67%) (Figure 3).

2.2.1.2 Cross-Slope

- a. ensure maximum gradient of 1:50 (2%).

2.2.1.3 Edge Protection

Provide edge protection along ramps and landings:

- a. with railings or other barriers that extend to within 50 mm of the finished ramp surface (Figure 4b & 4c); and

2.2.1.4 Colour Contrasting Strip

- a. provide a 50 +/- 10 mm yellow and slip-resistant strip at the beginning and end of ramp, and where landings meet a slope change (Figure 3).

Durham Accessibility and Inclusivity Requirements

April 8, 2022

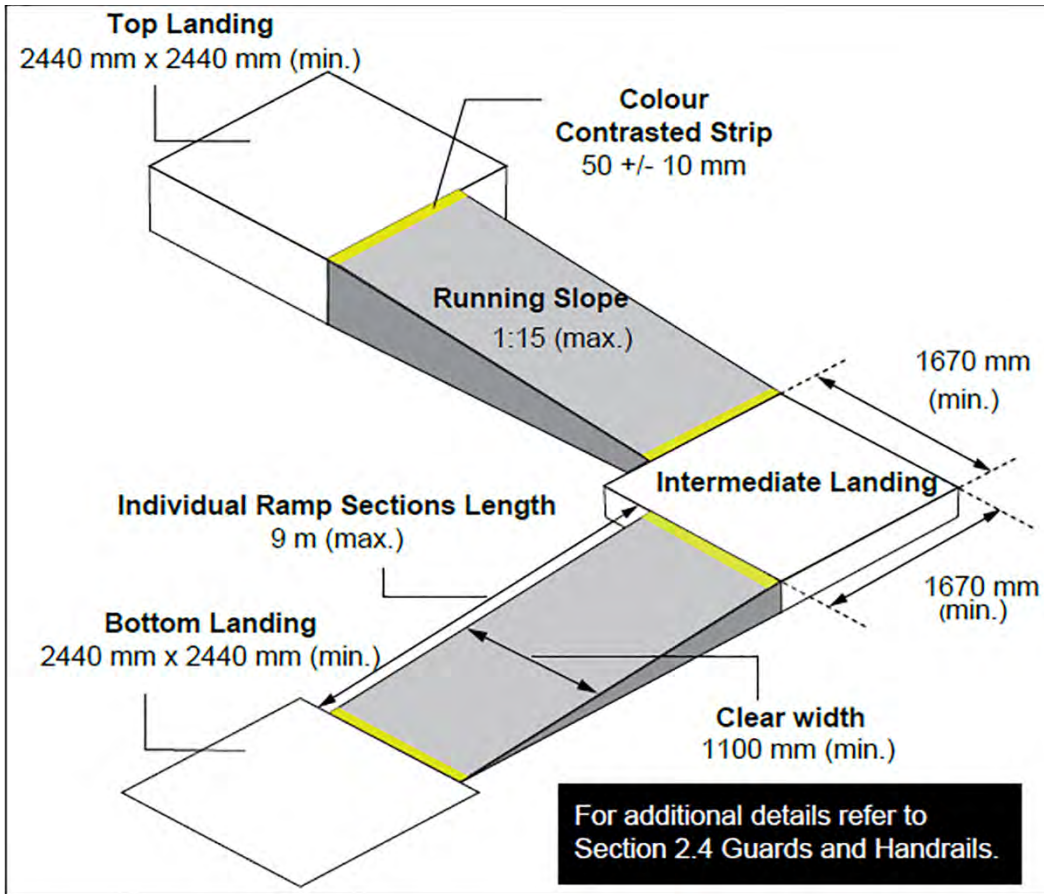

Figure 3: Ramp Design Features

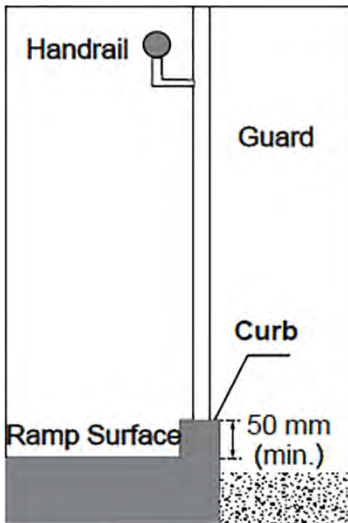

Figure 4a: Curb Protection - Cross Section

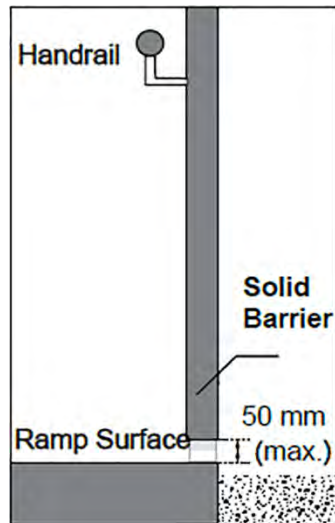

Figure 4b: Solid Barrier Protection - Cross Section

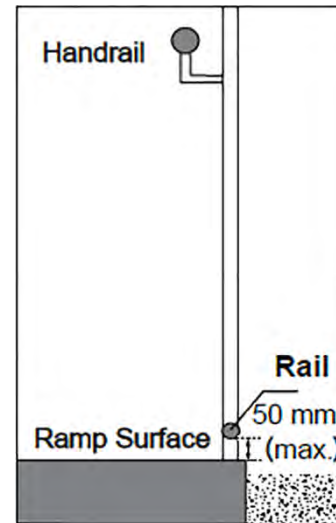

Figure 4c: Rail Protection - Cross Section

2.2.2 Landings

- a. ensure landings are level and have a cross slope that is not steeper than 1:50 (2%);

Durham Accessibility and Inclusivity Requirements

April 8, 2022

- b. provide clear space of 2440 mm by 2440 mm (minimum) at top and bottom landings (Figure 3) and where there is an abrupt change in direction a landing of 1670 mm by 1670 mm (Figure 5);
- c. where space is available, a landing dimension of 3150 mm by 3150 mm is preferred in order to accommodate powered wheelchairs and large scooters, respectively;
- d. provide clear space of 1670 mm (minimum) long and at least the same width as the ramp for an in-line landing;
- e. where overall length of ramp exceeds 9000 mm, provide intermediate landings; and
- f. where a door swings into ramp landing, ensure length of landing is extended:
 - i. 600 mm beyond the latch side of the door opening, when the door swings towards the ramp landing (Figure 6a); and
 - ii. 300 mm beyond the latch side of door opening, when door swings away from the ramp landing (Figure 6b).

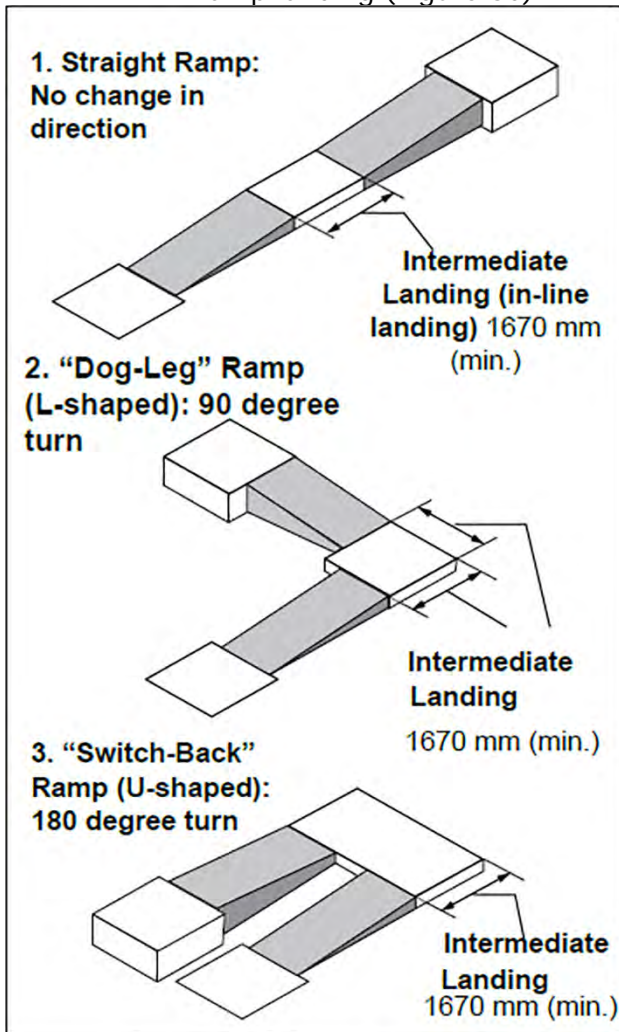

Figure 5: Typical Ramp Configurations

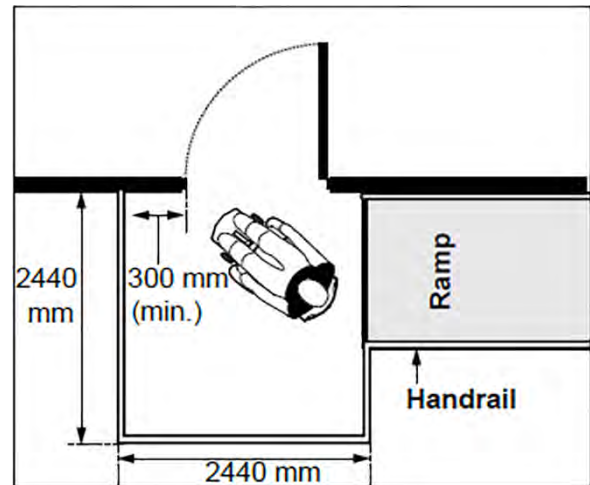

Figure 6a: Door Swings towards the Ramp Landing - Plan View

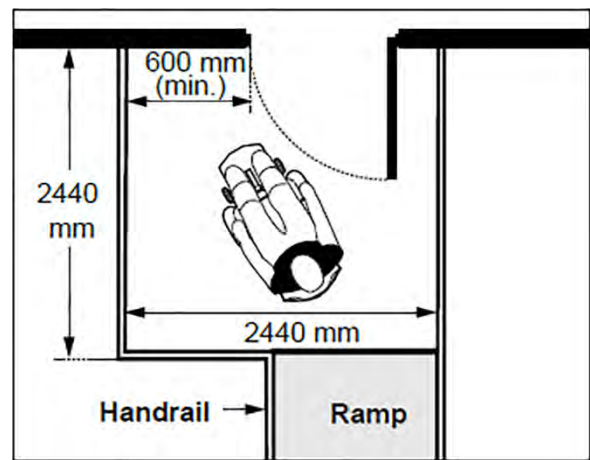

Figure 6b: Door Swings Away From Ramp Landing

2.2.3 Handrails and Guards

2.2.3.1 Handrails

- a. mount continuously on both sides of ramp, including landings, at consistent height between 865 mm and 920 mm, measured vertically from the surface of the ramp (Figure 8);
- b. provide clear width of 1100 mm (minimum) between handrails and / or any projections into the ramp surface (Figure 8);
- c. provide intermediate handrails so that
 - i. a handrail is reachable within 825 mm of all portions of the required exit width, and;
 - ii. at least one portion of the ramp between the two handrails is the required exit width.
- d. ensure high tonal contrast is provided between handrails and mounting surfaces; and
- e. provide extensions with the following criteria (Figure 7a & b):
 - i. extend horizontally 300 mm (minimum) at top and bottom landings;
 - ii. design to return to the guard / rail or wall; and
 - iii. ensure handrails are terminated in a manner that will not obstruct pedestrian path of travel or create potential bumping hazards.

Handrails that do not meet the vertical mounting requirements are permitted provided that they are installed in addition to the required handrail.

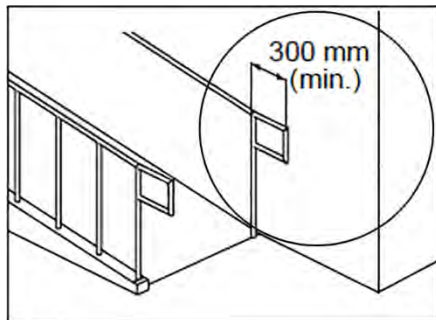

Figure 7a: Handrail Returns to Guard or Rail

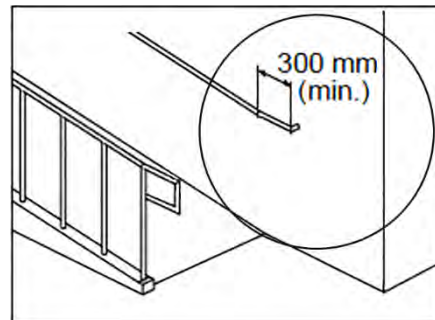

Figure 7b: Handrail Returns to Wall

2.2.3.2 Guards

Where walls or guards are required:

- a. mount at 1070 mm (minimum) high, measured vertically to the top of the guard from the ramp surface (Figure 9); and
- b. ensure that no guard, handrail, attachment or opening located between 140 mm and 900 mm high above the ramp surface will facilitate climbing.

For ramps under the jurisdiction of the Integrated Accessibility Standards Regulation (IASR), the ramp must have a wall or guard on both sides.

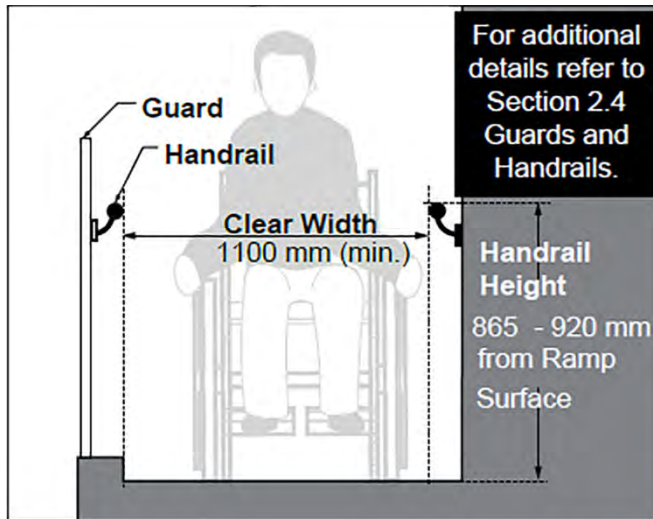

Figure 8: Handrail Design and Features - Section View

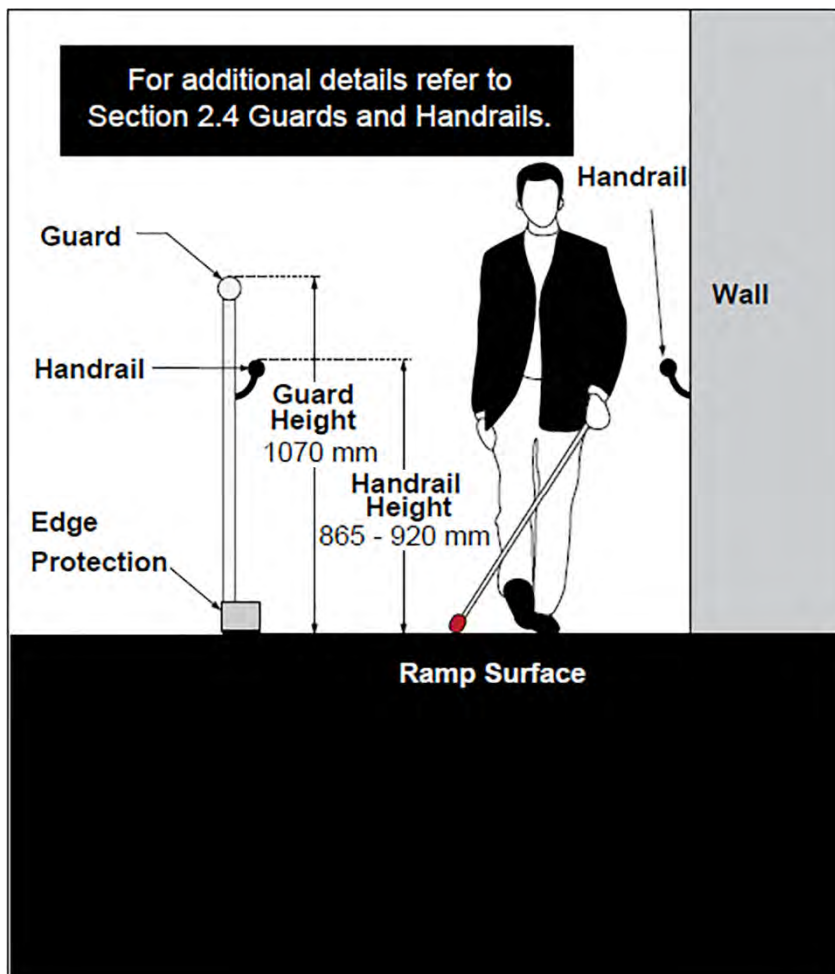

Figure 9: Guard Provision at Ramp - Section View

Durham Accessibility and Inclusivity Requirements

April 8, 2022

2.3 Stairs

Rationale

Stairs that are comfortable for many adults may be challenging for children, seniors or people of short stature. Poorly designed nosings can present tripping hazards, particularly to people with prosthetic devices or those using canes.

Cues to warn persons who are blind or have vision loss of an upcoming set of stairs are vitally important. Tactile walking surface indicators (TWSI) provided at the head of stair systems act as a warning, and tonal contrasted nosings increase the visibility of each step when descending, especially for users with vision loss.

The appropriate application of handrails will aid all users navigating stairways. They are an additional wayfinding guide for users with vision loss when continuous and if a strong tonal contrast is provided.

Application

This section applies to stair systems, where provided for exterior or interior environments.

Additionally, refer to the Ontario Building Code (OBC) and Integrated Accessibility Standards Regulation (IASR) requirements for stairs.

2.3.1 Design Features

- a. ensure surface is stable, firm, slip-resistant and non-glare; and
- b. provide lighting in accordance with Section 5.7 Lighting requirements, as applicable.

2.3.1.1 Treads and Risers

- a. riser height of 125 mm (minimum) to 180 mm (maximum) (Figure 10);
- b. tread depth of 280 mm (minimum) to 355 mm (maximum) (Figure 10);
- c. stairs must have closed risers; and
- d. ensure uniform riser height and tread depth throughout any stair system.

Riser height and tread depth standards do not apply to interior exit stairwells.

2.3.1.2 Nosings

- a. ensure no abrupt undersides;
- b. ensure they do not project more than 25 mm over the tread below and are sloped to the riser at an angle greater than 60 degrees to the horizontal;
- c. ensure leading edge is rounded or has a beveled profile, with a radius of curvature of between 8 mm and 13 mm (max) (Figure 10); and
- d. provide horizontal marking strips:
 - i. 50 mm (+/- 10 mm) deep;
 - ii. at the leading edge of the tread;
 - iii. with a high tonal contrast compared to tread and riser finishes with slip-resistant surface; and
 - iv. extend the full width of the tread.

Marking strips can also be fully integrated within the design of the nosing or finish used on the tread. For exterior stairs, exposed to the elements, and/ or stair systems that have a high level of pedestrian traffic, durable marking strips are recommended (e.g., carborundum).

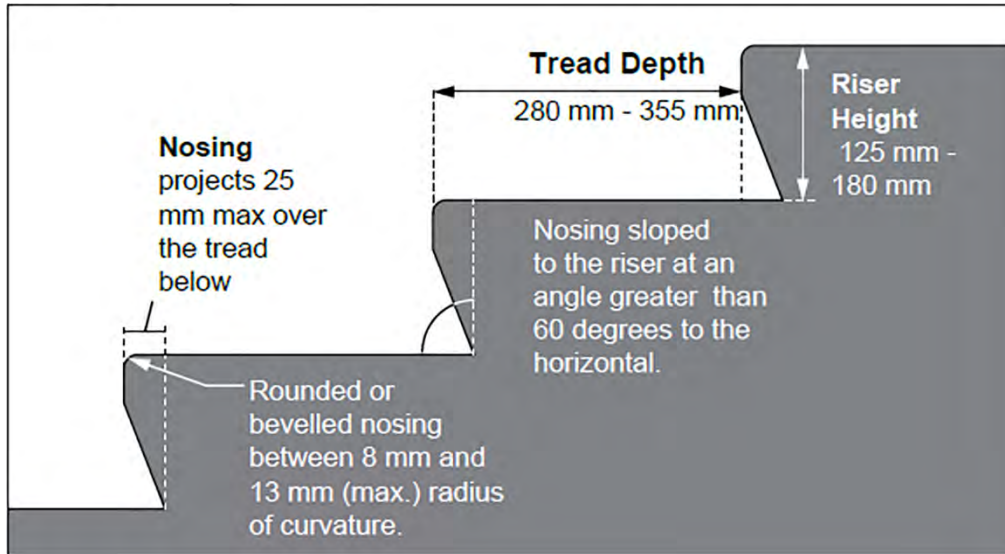

Figure 10: Stair Design Features - Section View

2.3.1.3 Tactile Walking Surface Indicators (TWSIs)

Provide tactile walking surface indicators (TWSIs):

- a. at the top of all flights of stairs starting one tread depth back from the leading edge of the top step; and
- b. at the top step, starting one tread depth back from the leading edge, at the following locations:
 - i. at each landing incorporating an entrance into a stair system;
 - ii. where the regular pattern of a stairway is broken; and
 - iii. where the run of a landing which does not have a continuous handrail is greater than 2100 mm;
- c. with surface depth of 610 mm, extending the full width of the stair (Figure 11).

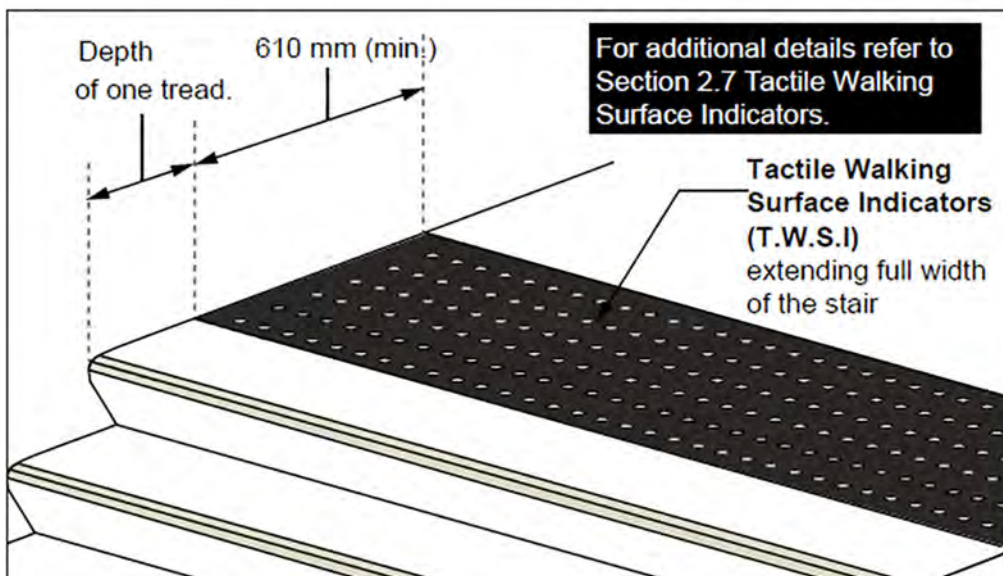

Figure 11: Tactile Walking Surface Indicators (TWSI) at Top of Stairs

Durham Accessibility and Inclusivity Requirements

April 8, 2022

2.3.2 Guards and Handrails

2.3.2.1 Guards

Where there is a change in level 600 mm or more in floor level adjacent to stairs, provide guards as follows:

- a. mount 1070 mm (minimum) high, measured vertically to the top of the guard from the stair surface;
- b. provide edge protection; and
- c. ensure that no member, attachment or opening located between 140mm and 900 mm high above the stair surface will facilitate climbing.

2.3.2.2 Handrails

- a. provide handrails where stair system contains three or more steps;
- b. mount on both sides of stairs, at a consistent height between 865 mm and 920 mm, measured from leading edge of stair tread (Figure 12);
- c. ensure high tonal contrast is provided between handrails and mounting surfaces for improved visibility;
- d. be continuous around landing less than 2100 mm in length from the top of stairs, except where the landing (Figure 13):
 - i. is intersected by an alternative accessible route; or
 - ii. has an entry door leading into it;
- e. be continuous on the inside edge of stairs
- f. provide intermediate handrails so that
 - i. a handrail is reachable within 825 mm of all portions of the required exit width, and
 - ii. at least one portion of the stair between the two handrails is the required exit width.
- g. provide extensions with the following criteria:
 - i. extend horizontally 300 mm (minimum) at top of flight of stairs, starting immediately above tread nosing;
 - ii. extend diagonally at the slope of the stair flight, for a horizontal distance equal to one tread depth beyond the bottom tread nosing, at bottom of flight of stairs then extend 300 mm parallel to the floor surface;
 - iii. design to return to the wall, guard or floor; and
 - iv. ensure handrails are terminated in a manner that will not obstruct pedestrian travel or create hazards.

Durham Accessibility and Inclusivity Requirements

April 8, 2022

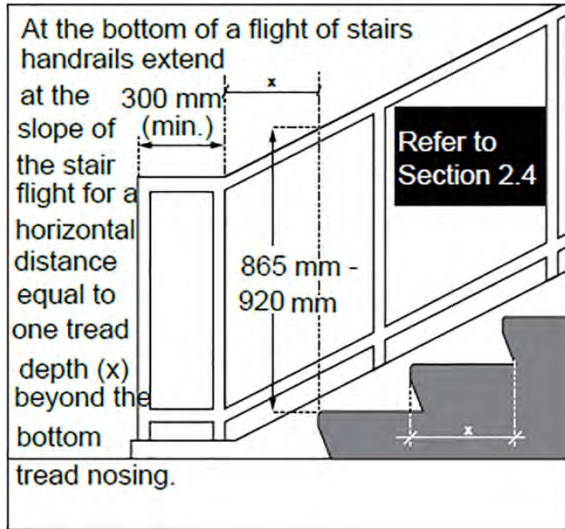

Figure 12: Handrail Extension at Stairs - Section View

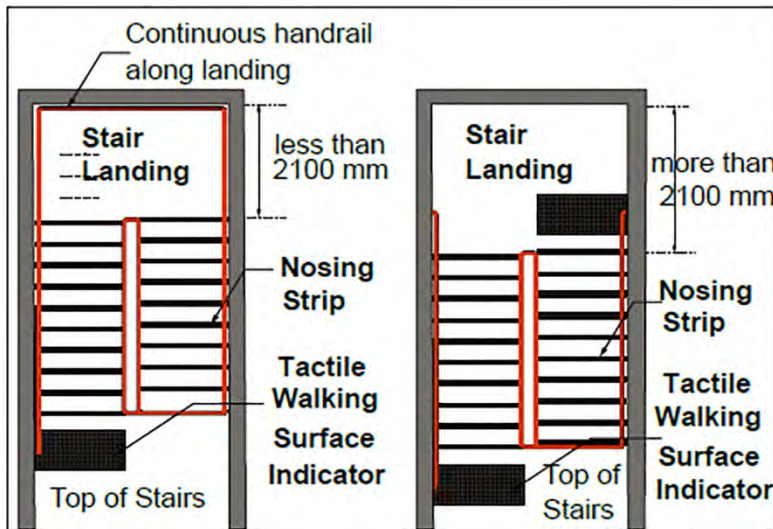

Figure 13: Continuous Handrails at Landings - Plan View

Durham Accessibility and Inclusivity Requirements

April 8, 2022

2.4 Guards and Handrails

Rationale

In the design of handrails, consideration must be given to the range of hands that will grasp them. A handrail profile should be graspable for an adult hand as well as a child or a person with arthritis. The same is true for the heights of handrails. In environments used frequently by children, lowered handrails are permitted, provided they are in addition to the required handrails.

Extensions of the handrails at the top and bottom of stairs, along with the use of a contrasting colour, provide important cues for those who are blind or have vision loss, and provide a support to ensure a safe and stable gait before ascending or descending the stairs. A continuous handrail with no interruptions ensures that a handhold will not be broken.

The clear space between the wall and handrail is also essential, as it must provide a clear area for the hand and knuckles but must not offer enough space into which an arm may slip during a fall or stumble on the stairs.

Application

This section applies to guards and handrails at ramps, stairs and other areas in both interior and exterior environments.

2.4.1 Guards

- a. ensure they comply with the OBC or IASR requirements, as applicable;
- b. mount at 1070 mm (minimum) high, measured vertically to the top of the guard from the ground / floor surface;
- c. design to prevent the passage of a sphere with a diameter greater than 100 mm; and
- d. ensure no member, attachment or opening located between 140 mm and 900 mm high above the level protected by the guard will facilitate climbing.

2.4.2 Handrails

- a. ensure handrails are continuous with grasping surface, uninterrupted by mounting brackets, newel posts or any other construction elements;
- b. provide rounded edges, free of abrasive elements;
- c. provide outside diameter between 30 and 40 mm for circular cross-section, which is preferred (Figure 14a & 14b);
- d. where non-circular cross sections are provided, ensure perimeter dimension of 100 mm (minimum) and 125 mm (maximum), with cross section dimension of 45 mm (maximum);
- e. provide clearance of 50 mm (minimum) between grasping surface and any adjacent surface (Figure 14a);
- f. provide clearance of 60 mm (minimum) between grasping surface and any adjacent rough surfaces;
- g. where handrails are in a recessed area, ensure clearance of 50 mm (minimum) between handrail surface and adjacent surface with clearance of 450 mm (minimum) above the handrail (Figure 14b); and
- h. be designed and constructed such that handrails and their supports withstand:
 - i. the loading values obtained from the non-concurrent application of a concentrated load not less than 0.9 kN applied at any point and in any direction; and
 - ii. a uniform load not less than 0.7 kN/m, applied in any direction.

Durham Accessibility and Inclusivity Requirements

April 8, 2022

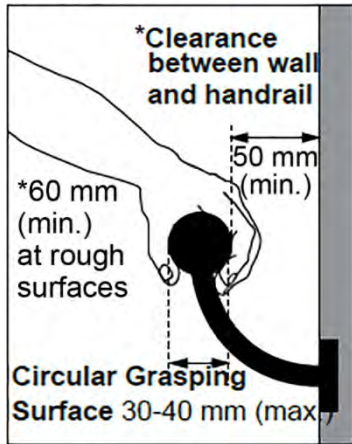

Figure 14a: Handrails on Wall - Section View

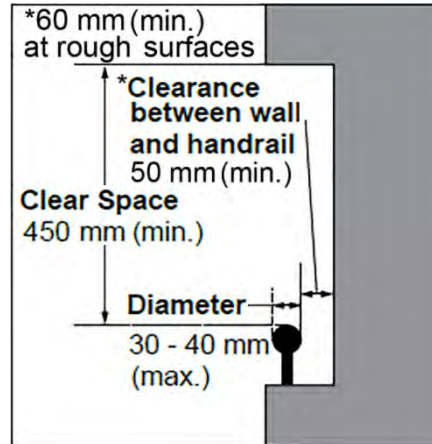

Figure 14b: Handrails in Recessed Area - Section View

2.5 Overhanging and Protruding Objects

Rationale

The creation of paths of travel that are free from protruding objects or freestanding obstacles is important for safety of all facility users. An unexpected object protruding from a wall especially if above the detection range of a cane is dangerous for those who are blind or have vision loss or a pedestrian distracted by a conversation. Temporary construction barriers can also be hazardous if their lower edge is too high to be detected by a person using a long white cane for mobility.

Providing enclosures at the underside of the stairs is important protection as this is a common overhead hazard. Railings, fixed planters or seating are all options for providing protection under stairs as long as they are placed within cane detection limits. Detectable warning surfaces around freestanding obstacles, such as light standards, may be advantageous to anyone using a pathway.

Application

This section applies to overhanging and protruding objects throughout and around facilities (interior and exterior environments) to prevent any hazard or obstruction for all users. Protruding objects are typically mounted on walls, ceilings or other locations adjacent to interior and exterior paths of travel.

2.5.1 Protruding Objects

Where objects protrude along accessible paths of travel:

- a. ensure the clear width of an accessible path of travel or maneuvering space is not reduced; and
- b. ensure objects protruding more than 100 mm from wall have a leading edge that is cane detectable (Figure 15).

2.5.2 Headroom Clearance

- a. provide 2100 mm (minimum) headroom clearance; and
- b. where the headroom clearance is less than 2100 mm over a portion of the accessible path of travel, provide a rail or other barrier with leading edge that is cane detectable around the object that is obstructing the headroom clearance (Figure 16).

2.5.3 Cane Detectable Leading Edge

Where an accessible path of travel is obstructed by overhanging or protruding objects, either the objects themselves must be cane detectable, or a rail or other barrier with a leading edge that is cane detectable must be provided.

- a. Wall mounted barriers must have a horizontal element at 680 mm high, or lower, to be detectable by people who use white canes (Figure 15).
- b. Floor mounted barriers such as curbs must be at least 50 mm high, unless they include a railing or other component that has a horizontal element at 680 mm high or lower.

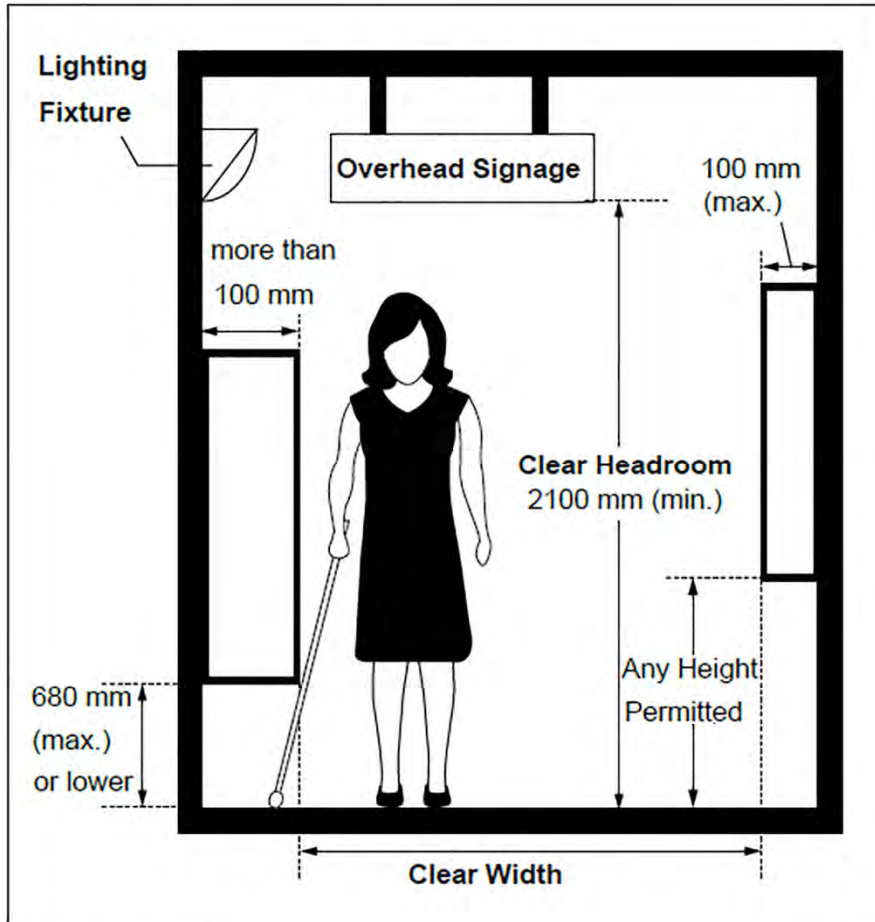

Figure 15: Protruding Objects

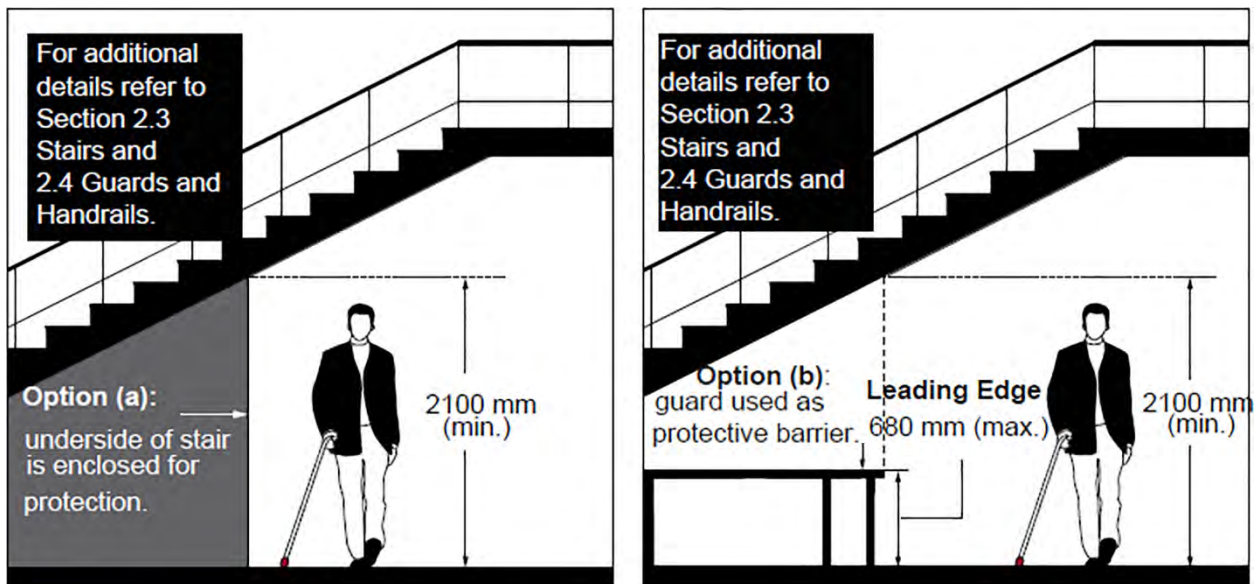

Figure 16: Protection Options Underneath Stairs

Durham Accessibility and Inclusivity Requirements

April 8, 2022

2.6 Rest Areas

Rationale

Benches provide convenient resting places for all individuals and are especially important for those who may have difficulty with standing or walking for extended periods. Benches are to be placed adjacent to pedestrian walkways to provide convenient rest places without becoming obstructions especially when in use. Those who are blind or have vision loss may find it easier to locate benches if they are located adjacent to a detectable landmark, such as a large tree, a bend in a pathway, or a sound source.

Application

This section applies to rest areas provided along accessible paths of travel within a facility or throughout exterior environments.

2.6.1 Consultation Requirements

When constructing new or redeveloping existing exterior paths of travel that will be maintained, consultation on the design and placement of rest areas must occur with:

- a. the public and people with disabilities; and
- b. the Durham Accessibility Advisory Committee.

2.6.2 Design and Placement

To determine the provision and placement of rest areas, consider the input received through the consultation process and other factors such as available space, property requirements, location of transit stops, and volume of pedestrian traffic. Consider providing rest areas, spaced no more than 30 metres apart, to maximize the usability of the paths of travel for people with reduced stamina.

Where rest areas are provided:

- a. ensure ground and floor surfaces are firm, stable and slip-resistant;
- b. in exterior environments, ensure surface has a slope no greater than 1:50 (2%) to allow suitable drainage, as well as maneuverability for users of mobility aids;
- c. consider providing contrast through ground finish, texture and / or tone to distinguish the rest area from the accessible path of travel;
- d. provide clear floor space of 915 mm wide by 1370 mm long (minimum) (Figure 17); and
- e. where seating is provided, ensure seating offers both armrests and backrests.

Durham Accessibility and Inclusivity Requirements

April 8, 2022

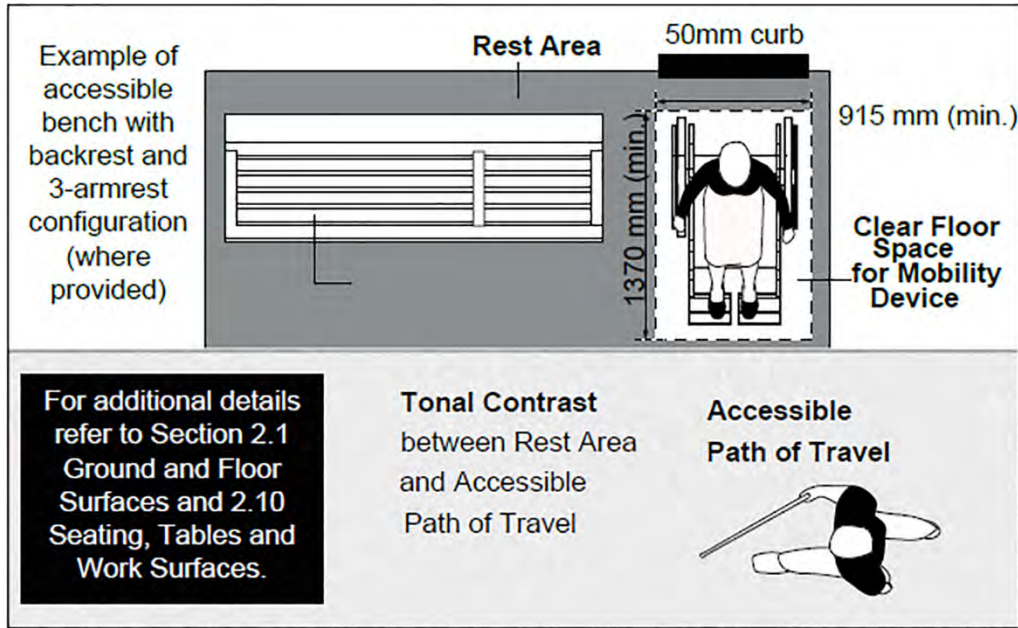

Figure 17: Rest Area - Plan View

Durham Accessibility and Inclusivity Requirements

April 8, 2022

2.7 Tactile Walking Surface Indicators

Rationale

Tactile walking surface indicators (TWSI) provide important navigational cues for people with a visual impairment. There are two types of indicators defined by the ISO. The type listed here are called Tactile Attention Indicators (TAI). These domed surfaces alert all pedestrians to potential hazards, such as crosswalks or stairs. To be effective TAIs are to include a change in texture and high colour and tonal contrast but design specifications have ensured they do not present a tripping hazard. The second kind of TWSI is called a Tactile Directional Indicator (TDI).

Application

Tactile Attention Indicators (TAI), also referred to as detectable warning surfaces, refers to a standardized surface, detectable underfoot or by a long white cane, to assist people with low vision or blindness by alerting them of an overhead or protruding hazard or a drop off (Illustrated Technical Guide to the Accessibility Standard for the Design of Public Spaces, GAATES, p. 201). TAIs should be used consistently throughout a facility and their typical locations include:

- at curb ramps and depressed curbs;
- where walking surfaces between pedestrian and vehicular areas are not separated by curbs; and
- at stairs and escalators.

Both cast in place (e.g. embedded within concrete) and surface applied TWSI systems are available for new construction and retrofits depending on the mounting surface and application. Surface applied systems require beveled edges to prevent potential tripping hazards. Moreover, simply applying tonal contrasted finish to a concrete surface does not provide appropriate tactile profile for detection by foot or cane.

2.7.1 Design Features

Provide tactile attention indicators (TAI) with:

- a. raised tactile profile;
- b. truncated domes (e.g., circular and flat-topped domes);
- c. slip-resistant and non-glare surfaces;
- d. a high colour and tonal contrast between the TAI and the adjacent surfaces; and
- e. edges beveled or level with surrounding surface (e.g. height of 3 mm or less).

2.7.2 Truncated Dome Specifications

- a. ensure flat-topped domes are 5 mm (+/- 1 mm) high (Figure 18);
- b. ensure the top of flat-topped domes are between 12 to 25 mm diameter;
- c. ensure diameter of the lower base of the flat-topped domes are 10 mm (+/-1 mm) more than the diameter of the top (e.g. a base diameter of 21 to 36 mm is typical);
- d. ensure domes are arranged in a square grid; and
- e. ensure spacing between adjacent flat-topped domes is adjusted depending on the size of the domes, as identified in Table 1.

Durham Accessibility and Inclusivity Requirements

April 8, 2022

Table 1: Truncated Dome Spacing Requirements

| Top Diameter of Flat Topped Domes (mm) | Spacing Between the Centres of Adjacent Domes (mm) |
|----------------------------------------|----------------------------------------------------|
| 12 | 42 to 61 |
| 15 | 45 to 63 |
| 18 | 48 to 65 |
| 20 | 50 to 68 |
| 25 | 55 to 70 |

For more information on requirements for truncated domes, refer to: ISO 23599:2012 "Assistive products for blind and vision-impaired persons -- Tactile walking surface indicators."

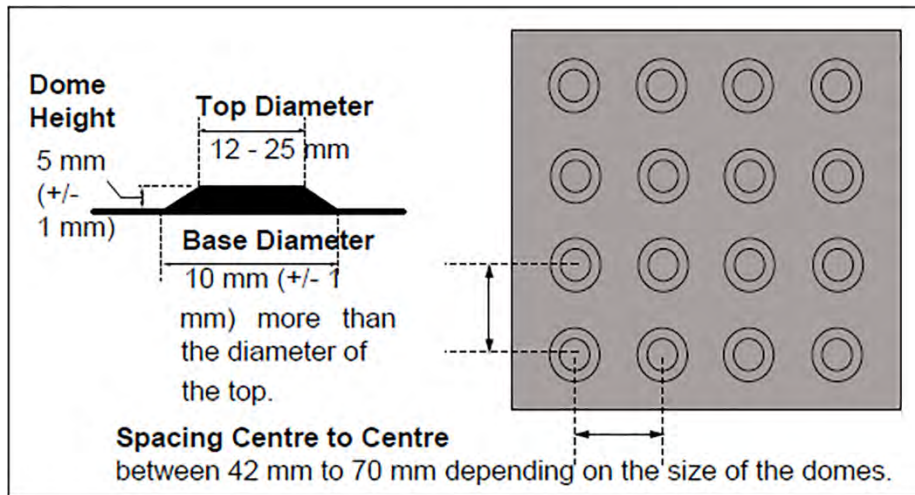

Figure 18: Truncated Dome Specification

Durham Accessibility and Inclusivity Requirements

April 8, 2022

2.8 Drinking Fountains

Rationale

Access to drinking water is an important accessibility accommodation. When planning the design of drinking fountains and water bottle filling stations, the design needs to consider the limited height of children and that of a person using a wheelchair or scooter, but also there may be individuals who have difficulty bending who would require a higher fountain. The provision of two drinking fountains, one at a lowered, accessible height and the other at a standing height meets the needs of diverse users. The operating system should account for limited hand strength or dexterity. Automatic or hands-free operating controls are preferred.

The placement of the fountain is also important. Fountains need to be recessed to avoid protruding into the path of travel. Angled walls into recessed alcove designs allow more flexibility and require less precision by a person using a mobility assistive device such as a wheelchair or scooter.

Application

This section applies to drinking fountains were provided throughout interior and exterior environments.

2.8.1 Design and Layout

Where drinking fountains are provided:

- a. ensure at least one drinking fountain is accessible to all users, including lowered units for people using mobility aids, people of short stature, children, others who may have trouble bending and people who have limited manual strength or dexterity;
- b. where only one drinking fountain is provided, ensure it is an accessible unit for people who use a wheelchair and who may have difficulty bending or stooping;
- c. ensure fountains are located adjacent to an accessible route, recessed or with a leading edge that is cane detectable at 680 mm (maximum) high, if they protrude into an accessible route;
- d. ensure drinking fountain fixtures provide a high tonal contrast with surroundings for easy identification.

2.8.2 Clear Floor Space Requirements and Approach

- a. provide clear floor space of 915 mm wide by 1370 mm deep (minimum) for forward approach (Figure 19);
- b. provide clear floor space of 1525 mm wide by 915 mm deep (minimum) for adjacent side approach (Figure 19);
- c. ensure one fully unobstructed side adjoins an accessible route or adjoins another clear floor area; and
- d. ensure clear floor space does not overlap the minimum space of the accessible route used to access the drinking fountain.

The space beneath the drinking fountain may be included as part of the clear floor area or turning space, provided that appropriate toe and knee clearances are available for a forward or parallel approach to an unrecessed or partially recessed drinking fountain.

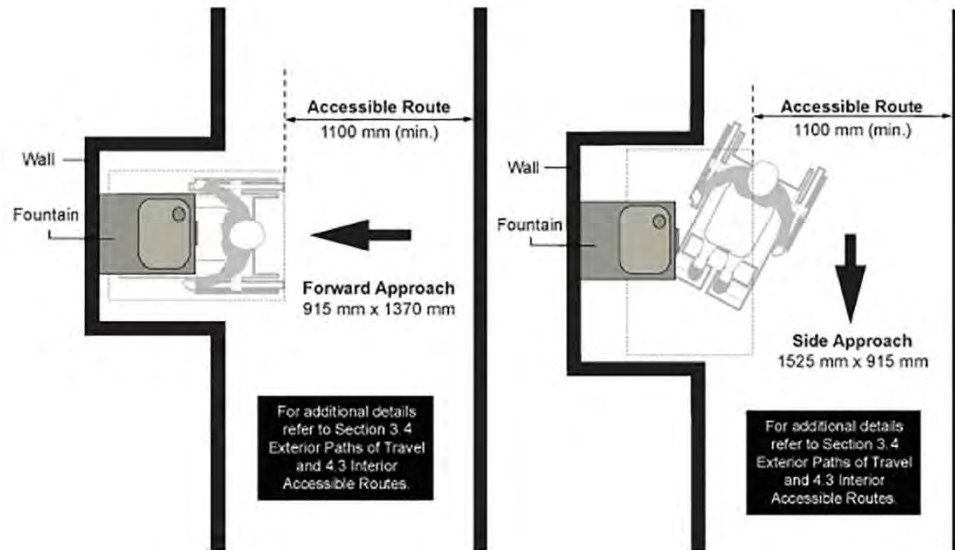

Figure 19: Clear Floor Space Requirements and Approach at Recessed Drinking Fountain - Plan View

2.8.3 Knee and Toe Clearances

Where accessible, lowered drinking fountains are provided:

- ensure clear knee space under the fountain is 760 mm wide by 200 mm deep at 735 mm high (minimum) above the floor (Figure 20);
- ensure clear toe space under the fountain is 350 mm above the floor from a point of 300 mm back from the front edge to the wall; and ensure the depth at the base of the fountain is 735 mm (minimum).

2.8.4 Operating Controls

Ensure fountain operating controls are:

- not foot-operated;
- located at or near the front of the drinking fountain (Figure 20); and
- operable with one hand, requiring a force of no more than 22 Newtons to operate without turning / twisting of the wrist or pinching of the fingers or operates automatically.

2.8.5 Water Spout

- mount no higher than 915 mm above the finished floor for accessible units;
- for standing use, mount between 965 and 1090 mm above floor;
- mount 125 mm (maximum) from the front of the drinking fountain, including bumpers, and 380 mm (minimum) from the vertical support;
- ensure water flows 100 mm high (minimum) to allow users who cannot use the drinking fountain to insert a cup under the flow of water; and
- ensure water flows at a vertical angle of:
 - 30 degrees maximum, where spouts are located less than 75 mm from the front of the unit; or
 - 15 degrees maximum, where water spouts are located between 75 mm and 125 mm from the front of the unit.

Durham Accessibility and Inclusivity Requirements

April 8, 2022

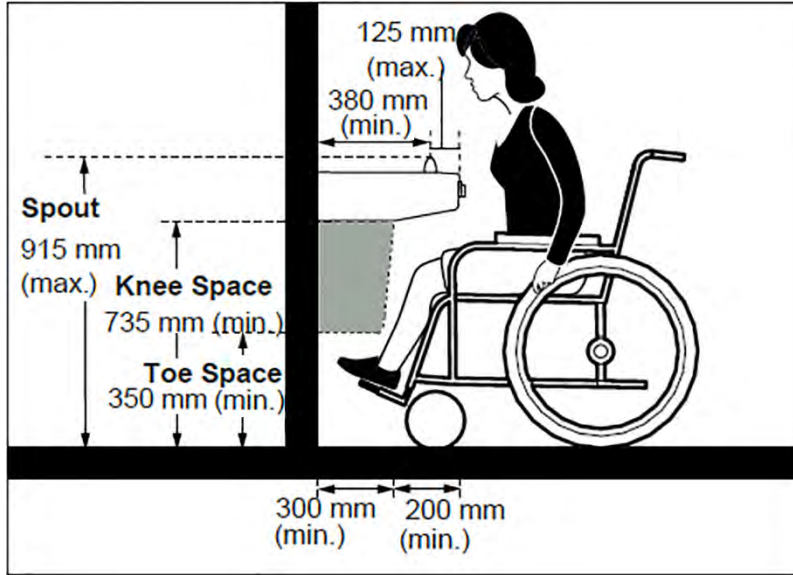

Figure 20: Drinking Fountain Design and Layout - Elevation View

Durham Accessibility and Inclusivity Requirements

April 8, 2022

2.9 Public Telephones

Rationale

The placement of telephones needs to address many factors including the limited reach of children, shorter people, people who are limb different or people in a seated position. Longer cords facilitate the use of the phone for someone unable to get close to the phone due to a mobility device or amputees. Adjustable volume controls are important for people who are hard of hearing or where background noise is loud, and shelves next to the phone are important to support a TDD device. Provision of a seat or fold-down seat is an asset to someone having difficulty standing for extended periods. Telephones projecting from a wall will present a horizontal protruding hazard, particularly for those who are blind or have vision loss, if the sides are not configured to be cane-detectable.

Application

This section applies to public telephones, which include coin operated, coin-less, and courtesy phones, located in both exterior and interior environments.

Public telephones can vary in design and style. Overall configuration is beyond the scope of these Standards and is typically the responsibility of the telephone service provider.

2.9.1 Provision

Where public telephones are provided, provide at least one accessible telephone unit on each accessible floor level as identified in Table 2.

Table 2: Minimum Number of Accessible Telephones Required

| Total Number of Telephone Units Located on Floor | Number of Telephone Units Required to be Accessible |
|--------------------------------------------------|-----------------------------------------------------|
| 1 or more single units | 1 per floor |
| 1 bank | 1 per floor |
| 2 or more banks | 1 per bank |

Where more than four public telephones are provided on an accessible floor level, equip one phone with a fixed T.T.Y. device, mounted below the phone without minimizing required knee space height for users of mobility aids.

2.9.2 Design and Layout

- a. provide directional signage to accessible public telephone location, if phone is hidden from view or mounted in a recessed area;
- b. mark with International Symbols of Accessibility and Hearing Loss, for accessibility features provided;
- c. provide clear floor space in front of accessible telephone unit (e.g., can be wall-mounted or hung in an enclosure) of (Figure 21):
 - i. 915 mm wide by 1370 mm depth (minimum) for a forward approach; and
 - ii. 1525 mm wide x 915 mm depth (minimum) for a side approach;
- d. ensure they are located adjacent to an accessible route, recessed or with a leading edge that is cane detectable at 680 mm (maximum) high, if they protrude into an accessible route;
- e. ensure overhead clearance of 2100 mm (minimum);
- f. where seating is provided in floor space, ensure it can be moved to accommodate users of mobility aids and people who prefer to stand;
- g. where stall or booth is provided for privacy and acoustics, provide sound-absorbing surfaces and ensure all required clearances are provided (e.g., floor space);
- h. provide lighting in accordance with Section 5.7 Lighting requirements, as applicable; and
- i. complies with CAN/CSA T515 Standards.

Durham Accessibility and Inclusivity Requirements

April 8, 2022

2.9.3 Telephone Operating Controls

- provide push button controls with large size numbers;
- ensure a high tonal contrast is provided between button and background, as well as numbering;
- ensure controls have a matte finish;
- mount operating controls, such as coin and card slots, push buttons and dispensers, at 1200 mm (maximum) from floor level (Figure 22);
- ensure maximum reach to all operating controls is 485 mm from front edge of phone cabinet or shelf;
- provide cord for telephone handset with length of 735 mm (minimum); and
- equip all accessible public telephones and a minimum of 25% of the total number of telephones with adjustable volume controls for users with hearing loss.

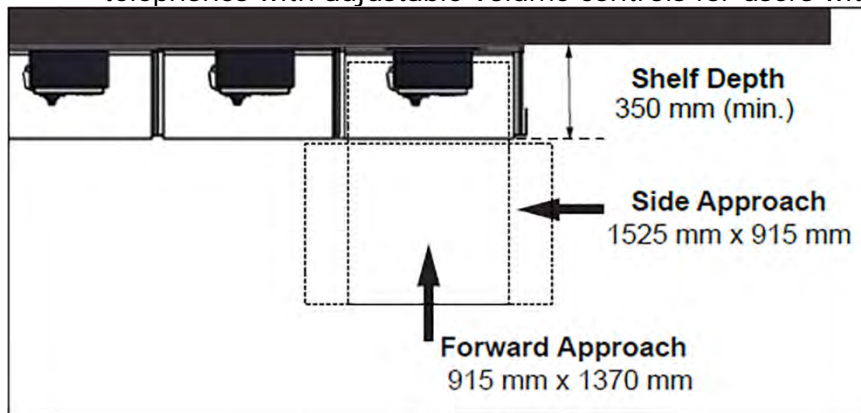

Figure 21: Clear Floor Space Requirements at Accessible Public Telephone

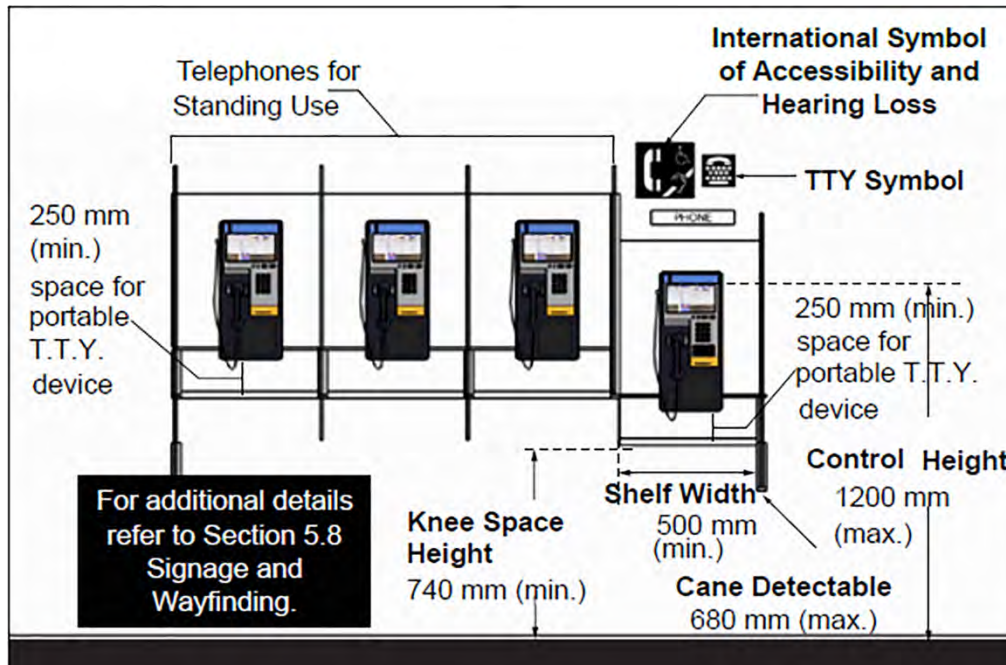

Figure 22: Public Telephone Provisions and Layout

2.9.4 Shelves and Counters

Where more than one telephone is provided for public use, provide a built-in shelf or counter underneath at least one telephone (Figure 22):

Durham Accessibility and Inclusivity Requirements

April 8, 2022

- a. ensure shelf or counter is level;
- b. 500 mm wide by 350 mm deep (minimum);
- c. mount top surface between 775 and 875 mm high above floor;
- d. ensure knee clearance is 740 mm high (minimum); and
- e. ensure a clear space of 250 mm (minimum) high between top of shelf and lower edge of phone equipment.

2.9.5 Text Telephones (T.T.Y.s)

Where fixed or portable teletypewriter (T.T.Y.) devices or connections are available:

- a. provide signage with the International Symbols of Accessibility and Hearing Loss and symbol for T.T.Y., to identify its location;
- b. provide adaptable controls to allow portable T.T.Y. connections, including adjacent electrical outlet where telephones are provided specifically to address the needs of users with hearing loss; and
- c. provide a long cord on telephone handset to allow connection to text telephone (T.T.Y.), if acoustic coupler is used.

Durham Accessibility and Inclusivity Requirements

April 8, 2022

2.10 Seating, Tables and Work Surfaces

Rationale

Benches provide resting places for all individuals and are especially important for those who may have difficulty with standing or walking for extended periods. Appropriate seat heights, back rests and armrests facilitate sitting and rising for most including individuals such as those with reduced strength and older persons. Where multiple benches are provided, consider option of some benches oriented to face each other where possible. This arrangement allows people to see each other, which is beneficial for people with hearing and communication disabilities to facilitate interaction. Also consider different configurations for armrests, transfer seating, clear floor space for assistive devices to sit in-line with the bench.

Tables, counters and work surfaces are to accommodate the needs of a range of staff and public needs. Consideration needs to be given to standing-use as well as seated use. For individuals using wheelchairs, tables need to be high enough to provide knee space and toe space so the clear space for assistive devices can sit under the table. The furniture placement at tables and the path of travel and manoeuvring space at counters include sufficient turning space for a person a mobility assistive device such as a wheelchair or scooter. Tables that have support leg(s) in the centre of the table may provide a higher level of accessibility as long as they do not block the required toe space.

Application

This section applies to site and facility furniture, provided in both exterior and interior environments which typically includes, but is not limited to seating (e.g. benches) tables and work surfaces. Some common locations, where site and facility furniture can be found are:

- rest areas and accessible routes;
- dining facilities;
- outdoor public use eating areas;
- waiting areas;
- lobbies; and
- office environments.

Furniture provisions should be reviewed on a case-by-case basis, specific to facility type and occupancy. Some locations may require more exterior site furnishings if high level of public traffic and use is expected.

2.10.1 Benches and Seats

Provision of benches and seats are typically recommended for people who may have difficulty with standing or walking for extended periods, limited stamina, or for users of mobility aids.

For accessible benches and seating provided in both interior and exterior environments:

- a. ensure seating is located on an accessible route;
- b. ensure seat height is between 450 and 500 mm above finished floor ground (Figure 23);
- c. ensure seat depth is between 330 and 510 mm;
- d. provide back support, extending 320 mm (minimum) above the seat surface, or affix the seat to a wall;
- e. provide at least one (1) arm rest at a height between 220 and 300 mm from the seat for additional support;
- f. Where only one bench is provided, ensure it is accessible with a three (3) arm rest configuration: one provided at each end and one within the middle.

Durham Accessibility and Inclusivity Requirements

April 8, 2022

- i. Where an arm rest is provided in the middle of the seat, ensure it is located one seat-width from an arm at the end of the bench. For example, a three-seat bench would have the middle arm at 1/3 of the width whereas a two-seat bench would have the middle arm at 1/2 of the width. Refer to Rest Areas 2.6.2 section for details on design and placement.
- g. ensure bench is stable at all times;
- h. ensure seating surfaces provide high tonal contrast with surroundings to enhance visibility; and
- i. refer to Section 2.6.2 Rest Areas Design and Placement and Figure 17 - Rest Area - Plan View.

Where an arm rest is provided in the middle of the seat, ensure it is located one seat-width from an arm at the end of the bench. For example, a three-seat bench would have the middle arm at 1/3 of the width whereas a two-seat bench would have the middle arm at 1/2 of the width. Refer to Rest Areas 2.6.2 section for details on design and placement.

Where multiple benches are provided, consider different armrest configurations, including benches with no armrest on one side to allow users in mobility devices to transfer to the bench seat if desired.

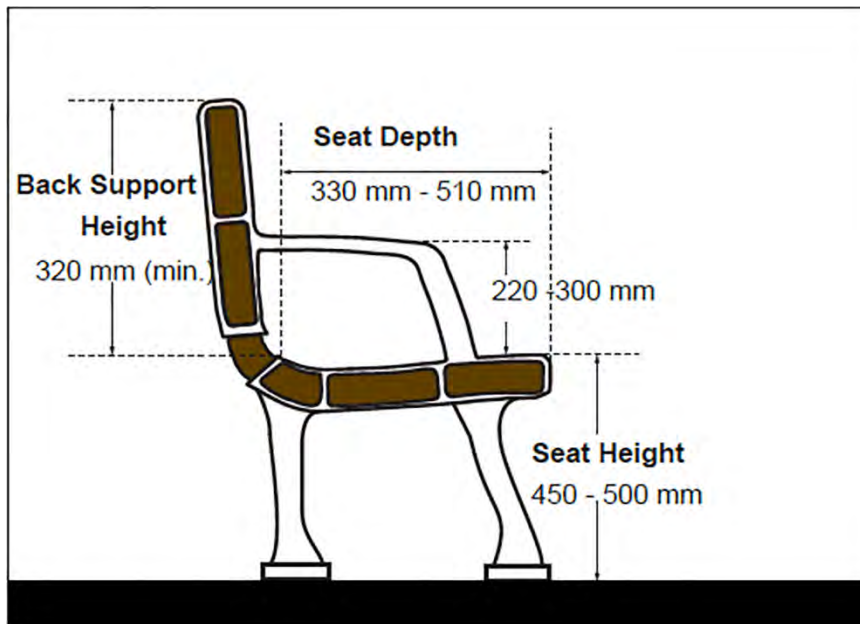

Figure 23: Typical Accessible Bench Dimensions - Section View

2.10.2 Tables and Work Surfaces

- a. ensure tables and work surfaces are located on an accessible route;
- b. ensure top surface is between 710 mm and 865 mm high (Figure 24a);
- c. provide clear knee space of:
 - i. 760 mm wide (minimum);
 - ii. 480 mm (minimum) deep by 685 mm high (minimum);
- d. where toe clearance is required based on table design, ensure toe space is 350 mm (minimum) high by 230 mm (minimum) deep;
- e. ensure top surface and edges provide a high contrast with adjacent surroundings to enhance visibility;
- f. ensure clear floor space provided at table and work surfaces for users of mobility aids is (Figure 24b):

Durham Accessibility and Inclusivity Requirements

April 8, 2022

- i. 915 mm wide by 1370 mm deep (minimum), of which 480 mm (maximum) may be under the table for forward approach; or
 - ii. 1525 mm wide by 915 mm deep (minimum) for a side approach; and
- g. provide a clear space or ground space with turning diameter of 2440 mm, to allow both side and front approach by users of larger wheeled mobility aids, such as powered scooters and wheelchairs.

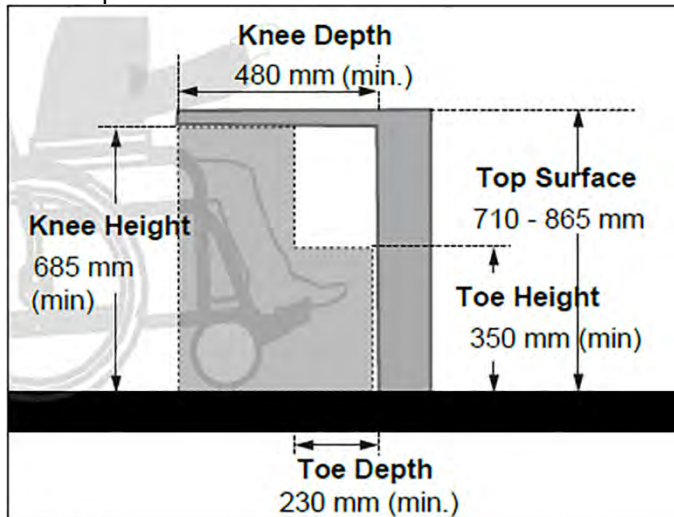

Figure 24a: Knee and Toe Clearances - Elevation View

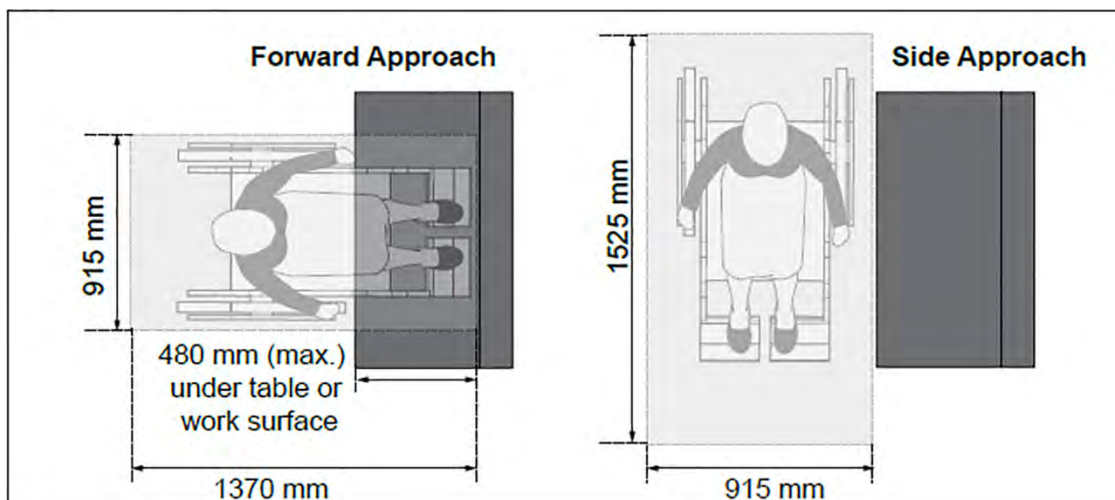

Figure 24b: Clear Floor Space Requirements and Approach at Tables and Work Surfaces - Plan View

Durham Accessibility and Inclusivity Requirements

April 8, 2022

3.0 Exterior Elements

3.1 Parking

Rationale

The provision of parking spaces, especially accessible and proximity parking near the entrance to a facility is important to accommodate staff and the public with a varying range of abilities as well as people with limited mobility. Medical conditions, such as arthritis or heart conditions, those using crutches or pushing a manual wheelchair, all may make it travelling longer distances difficult. Minimizing travel distances is particularly important outdoors, due to weather conditions and ground surfaces.

In addition to the proximity to entrances, the sizes of accessible parking spaces is important. A person using a mobility aid such as a wheelchair or scooter requires a wider parking stall and access aisle to accommodate the manoeuvring of the wheelchair beside the car or van. A van may also require additional space to deploy a ramp or lift through the side or back door, requiring space for the deployment of the ramp or lift as well as additional space to manoeuvre on and off.

Heights along the routes to and at accessible parking is a factor. Accessible vans may have a raised roof resulting in the need for additional overhead clearance. Alternatively, sometimes the floor of the vehicle may be lowered, resulting in lower tolerances for speed bumps and pavement slope transitions.

The number of accessible parking spaces required by this section may not be sufficient in some facilities (such as seniors' centres) where an increased number of people with disabilities may be expected. In this situation, the number of accessible parking spaces may be increased from the requirements in this standard.

Wherever possible ensure parking signs do not block or present an overhead and/or protruding hazard to pedestrian routes. It is preferable that the sign be placed at the curb line closest to the parking space to denote the end of the space to improve visibility. Where spaces are configured such that the front or rear of parked vehicles is immediately adjacent to a pedestrian walkway, consider a design that prevents vehicle overhangs which could reduce the width of the walkway. Ensuring pedestrian safety, accessible routes from each parking space is to be provided so that people are not using the drive aisle and passing behind parked cars. Ensure any pedestrian crossing or travel area is clearly marked so it is visible to both drivers and pedestrians.

Accessible staff and public parking spaces and adjacent access aisles are to be regularly maintained, sloped for drainage, kept clear of debris and snow, and wherever possible, have overhead protection from the elements (e.g. such as direct sun, rain or snow).

Application

This section applies to accessible parking spaces provided for the following types of exterior or interior parking facilities:

- parking garages or related structures (e.g. above or below grade);
- surface parking; and
- off-street parking.

Exception

Off-street parking facilities that are used exclusively to park the following types of vehicles:

- buses;
- delivery vehicles;
- law enforcement vehicles;
- medical transportation vehicles, such as ambulances; and impounded vehicles.

Durham Accessibility and Inclusivity Requirements

April 8, 2022

The requirements in respect to off-street parking facilities do not apply to off-street parking facilities if:

- the off-street parking facilities are not located on a barrier-free path of travel, regulated under Ontario's Building Code;
- the facility is one of multiple off-street parking facilities on a single site that serves a building or facility, where appropriate accessible parking facilities are provided elsewhere on the same site.

3.1.1 Types of Parking

Two (2) types of accessible parking spaces are required where parking is provided:

- a. Type A spaces (minimum 3400 mm wide) shall consist of wider parking spaces which accommodate larger vehicles such as vans that are equipped with transfer ramps for users of wheeled mobility aids; and
- b. Type B spaces (minimum 2600 mm wide) are standard parking spaces which accommodate users who are ambulatory but have limited mobility and cannot travel lengthy distances, or use other mobility aids, such as canes, crutches and walkers.

3.1.2 Provision

- a. provide minimum number of Type A and Type B spaces in accordance with Table 3;
- b. where possible, provide 4% of the total parking spaces as accessible spaces divided evenly between type A and Type B spaces;
- c. where a parking facility serves multiple buildings or accessible entrances, distribute accessible parking spaces to enable users to park near as many accessible entrances as possible;
- d. where more than one parking facility is provided at a site:
 - i. ensure the number and type of accessible parking spaces provided is determined based on the total number of parking spaces required for each of the separate parking facilities; and
 - ii. locate and distribute accessible parking spaces among the off-street parking facilities in a manner that provides substantially equivalent or greater accessibility in terms of distance from an accessible entrance or user convenience (e.g. protection from weather, lighting, security and comparative maintenance)
- e. where the parking facility is a multi-level parking facility, ensure the accessible parking spaces are easy to identify and have at least one accessible route leading to an entrance, exit or elevator lobby.

Durham Accessibility and Inclusivity Requirements

April 8, 2022

Table 3: Accessible Parking Provision Requirements

| Total Number of Parking Spaces | Minimum Number of Accessible Spaces Required | Number of Type A-Van | Number of Type B |
|--------------------------------|----------------------------------------------|----------------------|------------------|
| 1-12 | 1 | 1 | 0 |
| 13-25 | 1 | 1 | 0 |
| 26-50 | 2 | 1 | 1 |
| 51-75 | 3 | 1 | 2* |
| 76-100 | 4 | 2 | 2 |
| 101-133 | 5 | 2 | 3* |
| 134-166 | 6 | 3 | 3 |
| 167-250 | 7 | 3 | 4* |
| 251-300 | 8 | 4 | 4 |
| 301-350 | 9 | 4 | 5* |
| 351-400 | 10 | 5 | 5 |
| 401-450 | 11 | 5 | 6* |
| 451-500 | 12 | 6 | 6 |
| 501-550 | 13 | 6 | 7* |
| 551-600 | 14 | 7 | 7 |
| 601-650 | 15 | 7 | 8* |
| 651-700 | 16 | 8 | 8 |
| 701-750 | 17 | 8 | 9* |
| 751-800 | 18 | 9 | 9 |
| 801-850 | 19 | 9 | 10* |
| 851-900 | 20 | 10 | 10 |
| 901-950 | 21 | 10 | 11* |
| 951-1000 | 22 | 11 | 11 |
| 1001 and over | 11+1% of total | | |

- *(1) Where an even number is required, provide equal number of Type A and B
- (2) Where an odd number is required, provide equal number of Type A and B. The additional space, the odd numbered space, may be a Type B parking space.
- (3) The values are derived from formulas contained in Ontario Regulation 191/11. The Regulation uses percentages to determine the number of spaces that are to be accessible and ratios to divide them between Type A or Type B.
- (4) Where facilities may expect a higher proportion of people with disabilities using their services (e.g. Seniors' Centres, Long Term Care and other medical facilities), the provision of additional accessible parking spaces is to be determined on a case by case basis. The appropriate number of spaces may be calculated based on the anticipated demand and a detailed review of the facility's occupancy levels.

3.1.3 Design and Layout

- a. locate accessible parking spaces within 30 metres of an accessible entrance and integrate with an accessible route;
- b. ensure ground surface is firm, stable and slip-resistant;
- c. maximum running slope of surface at 1:50 (2%);
- d. maximum cross-slope of surface at 1:50 (2%);
- e. length of 5400 mm (Figure 25);
- f. minimum width of 3400 mm for "Type A" wide van accessible spaces and minimum width of 2600 mm for "Type B" standard parking spaces (Figure 25);
- g. provide an access aisle adjacent and parallel to each accessible parking space (Figure 25):

Durham Accessibility and Inclusivity Requirements

April 8, 2022

- i. 1500 mm wide (minimum);
 - ii. extend the full length of the space;
 - iii. clearly indicated by high colour contrast diagonal pavement markings;
 - iv. where two accessible parking spaces are provided adjacent to each other, they may share an access aisle;
 - v. connect with adjacent accessible path of travel and centre curb ramp on access aisle;
- h. accessible parallel parking spaces min 7250mm long by 4600 mm wide;
 - i. ensure vertical height clearance of 2100 mm (minimum) at designated parking spaces and along the vehicle access and egress routes;
 - j. provide vertical height clearance of 2750 mm (minimum) to accommodate larger vehicles; and
 - k. provide lighting in accordance with Section 5.7 Lighting requirements, as applicable.

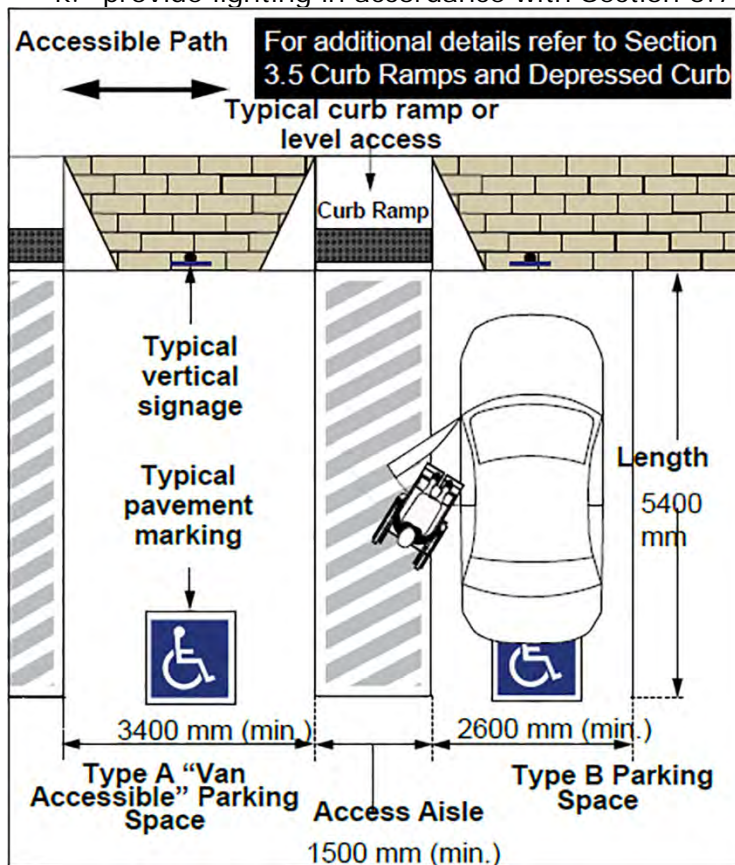

Figure 25: Accessible Parking Space Dimensions - Plan View

3.1.4 Signage and Pavement Markings

- a. ensure spaces are clearly designated with pavement markings and vertical signage, containing the International Symbol of Accessibility and in accordance to Section 11 of Regulation 581 of the Revised Regulations of Ontario, 1990 (Accessible Parking for Persons with Disabilities) (Figure 26 and 27); and
- b. provide directional signage, marked with the International Symbol of Accessibility, to indicate the location of accessible parking spaces, and/or the location of the nearest accessible entrance if the spaces or entrance are not easy for users to locate when entering or using the site.

Durham Accessibility and Inclusivity Requirements

April 8, 2022

3.1.4.1 Vertical Signage

- a. each accessible parking space must be identified with an accessible parking permit sign (Figure 26) as per Section 11 of the Revised Regulations of Ontario, 1990 (Accessible Parking for Persons with Disabilities) made under the Highway Traffic Act;
- b. ensure size of 300 mm wide by 450 mm high (minimum);
- c. mount at height of 1500 mm to 2500 mm (centre) (e.g. wall or post-mounted), from ground/floor
- d. ensure a high tonal contrast is provided between sign and background environment;
- e. provide information text, compliant with City By-law requirements; and
- f. in addition, a Type A space must also have a sign identifying the space as "Van Accessible".

3.1.4.2 Pavement Marking

- a. mark with International Symbol of Accessibility (Figure 27);
 - i. ensure 1525 mm wide by 1525 mm depth (minimum);
 - ii. provide a white or yellow border with a blue background field colour;
 - iii. locate near the entrance of the space for 90 degree or angled parking spaces and centered for parallel parking spaces; and
- b. ensure all pavement markings are slip resistant and clearly visible through use of high tonal contrast compared to the surface of the parking space.

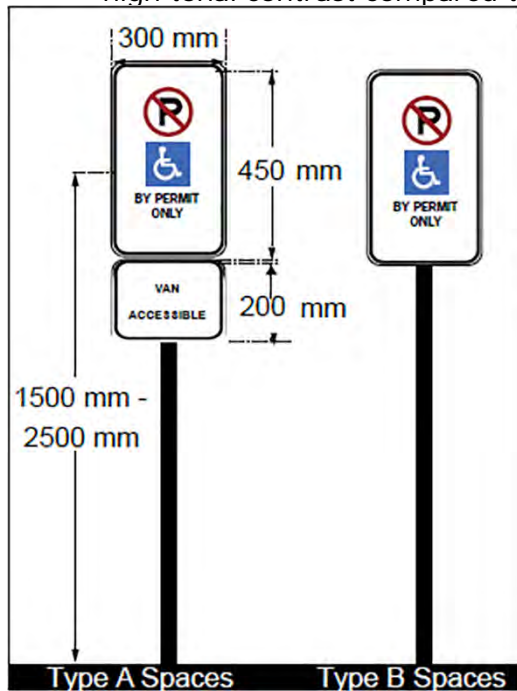

Figure 26: Accessible Parking Vertical Signage

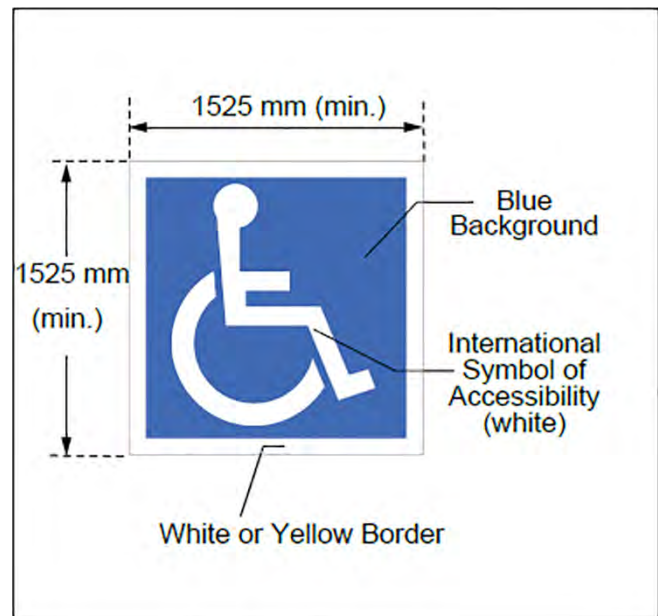

Figure 27: Accessible Parking Pavement Marking

Durham Accessibility and Inclusivity Requirements

April 8, 2022

3.2 EV Charging Parking Spaces

Rationale

Having EV charging stations on the property supports Durham Region's commitment to sustainability. EV charging stations can also support Leadership in Energy and Environmental Design (LEED) certification. Ensuring all staff and public EV Charging locations are accessible also supports the region's diversity and inclusion goals. The location, space at the controls, access to accessible paths of travel, lighting and signage are all integral to successful and usable designs for all users.

Application

This section applies to EV parking spaces and charging stations provided for the following types of exterior or interior parking facilities:

- parking garages or related structures (e.g. above or below grade);
- surface parking; and
- off-street parking.

While the indicated EV parking spaces are sized to match accessible parking requirements, they are not specifically accessible spaces, and they do not count toward minimum accessible parking requirements.

3.2.1 EV Parking Design and Layout

- a. 100% of EV parking spaces shall be designed to be accessible;
- b. EV parking spaces shall be designed to match the size requirements of accessible parking spaces as indicated in Section 3.1 Parking for Type A and Type B spaces;
- c. The number of Type A spaces provided shall at least equal to the number of Type B spaces provided at each location;
- d. Where a parking facility serves multiple buildings or accessible entrances, distribute EV parking to enable users to park near as many entrances as possible;
- e. EV parking spaces should be located as close to the building entrances as possible;
- f. Ensure ground surface is firm, stable and slip-resistant;
- g. Maximum running slope of surface at 1:50 (2%)
- h. Maximum cross slope of surface at 1:50 (2%)
- i. Provide access aisle adjacent to each EV parking space
 - i. Minimum 1500 mm wide located on both sides, and parallel to the EV parking space and extending the full length of the space;
- j. Where users require accessible access to buildings or other site amenities, provide access aisle in front of each bank of EV parking spaces
 - i. Minimum 1960 mm wide located in front of and perpendicular to all EV parking spaces and access aisles;
 - ii. Extending continuously across the full width of the entire EV charging bank of spaces and access aisles; and
 - iii. Connecting to an adjacent accessible path of travel providing access to building entrance or other site amenities with a curb ramp that complies with Section 3.5 Curb Ramps and Depressions.
- k. Where EV parking spaces are provided for users who are expected to remain with their vehicle during the charging process, provide an access aisle in front of each bank of EV parking spaces
 - i. Minimum 1500 mm wide located in front of and perpendicular to all EV parking spaces and access aisles; and
 - ii. Extending continuously across the full width of the entire EV charging bank of spaces and access aisles.

Durham Accessibility and Inclusivity Requirements

April 8, 2022

- l. Provide bollards at the head of each parking space to prevent vehicles from encroaching upon any access aisle or accessible path of travel. Provide minimum 950mm clearance between adjacent bollards.

3.2.2 EV Parking Signage and Pavement Markings

- a. Ensure all EV parking spaces are clearly designated with pavement markings and vertical signage, indicating use for EV charging only.
- b. Locate pavement markings near entrance of the space.
- c. Ensure all pavement markings are slip resistant and clearly visible through use of high tonal contrast compared to the surface of the parking space.
- d. All signage to comply with section 5.8.1 Signage.
- e. Provide lighting in accordance with Section 5.7 Lighting.

3.2.3 EV Charging Stations (EVCS) and Controls

- a. EV Charging Stations to be mounted on parking/access aisle surface. No curbs or other barriers should prevent or restrict access to EVCS.
- b. Provide a clear space of at least 1350 x 800 mm for parallel or front approach, centered on the EV controls.
- c. Controls to be colour contrasted with their background.
- d. All controls and operable elements to be located between 900 – 1100 mm above ground surface.
- e. Power cord to be self-retracting to prevent cords from blocking accessible path or access aisles.
- f. Display screens to be glare-free and protected from direct sunlight.
- g. Where possible, display elements should provide options for changing font height, display colours, and/or screen contrast.
- h. All controls and operable elements to comply with Section 5.1 Controls and Operating Mechanisms.

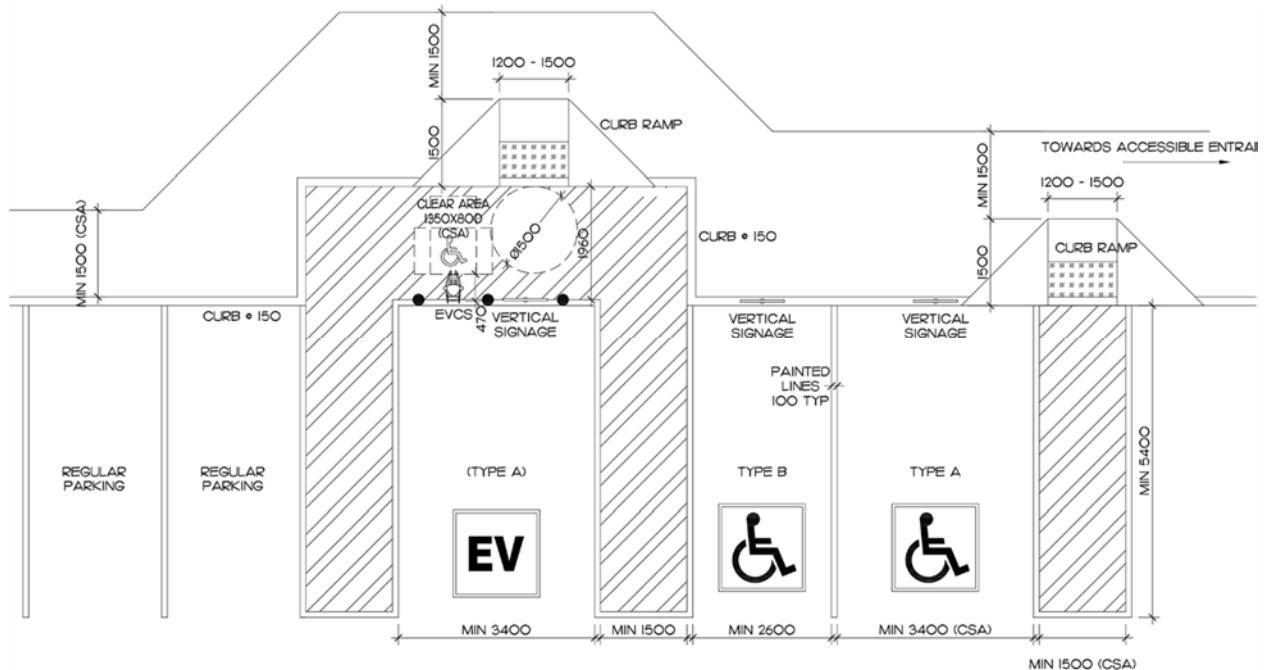

Figure 28: Single EV Charging Parking Space, adjacent to Accessible Parking

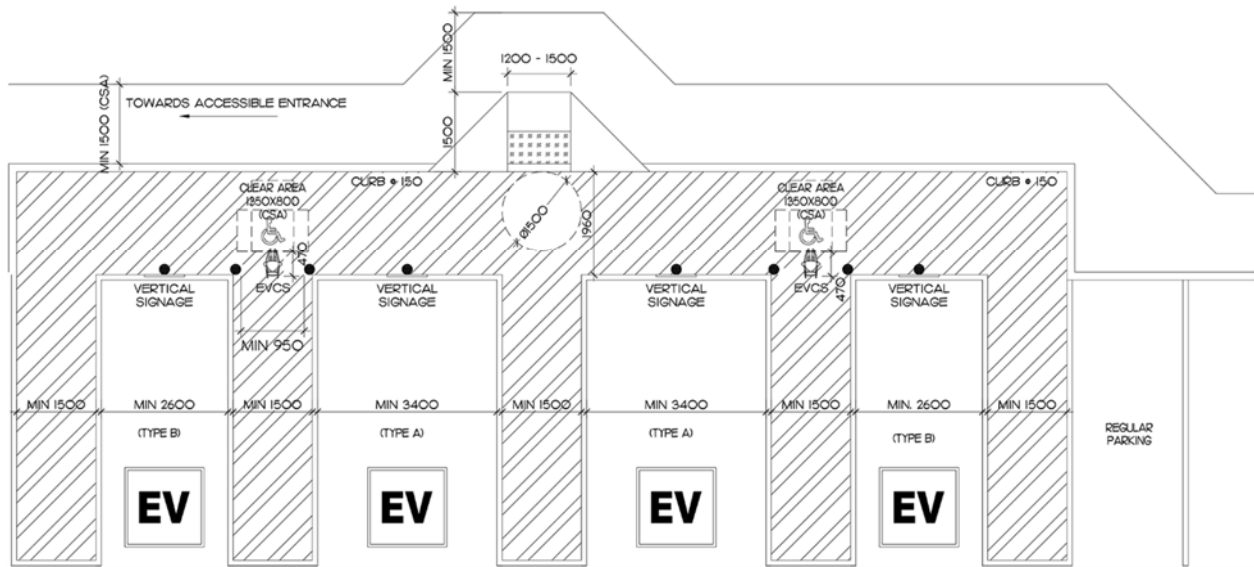

Figure 29: Multiple EV Charging Parking Spaces at adjacent Accessible Path of Travel

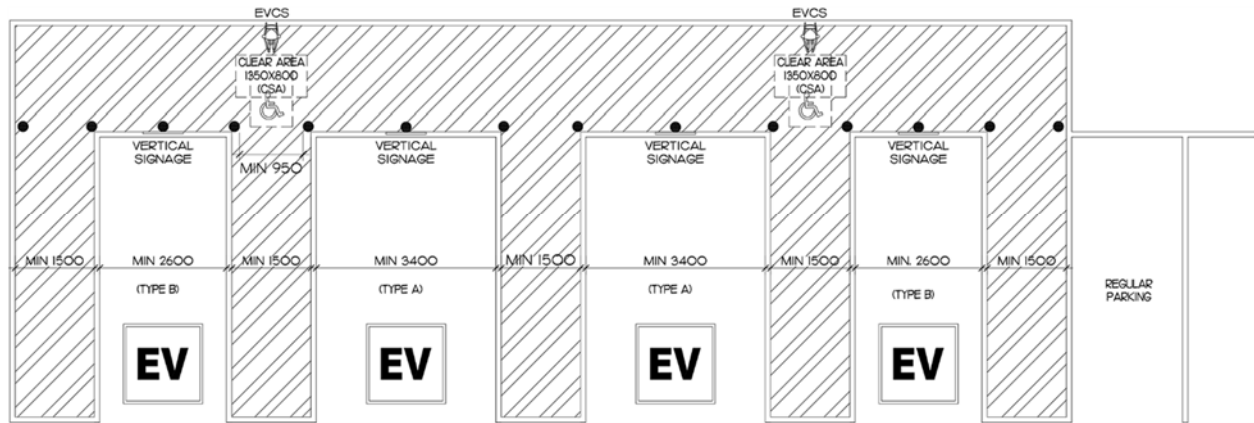

Figure 30: Multiple EV Charging Parking Spaces without Accessible Path of Travel

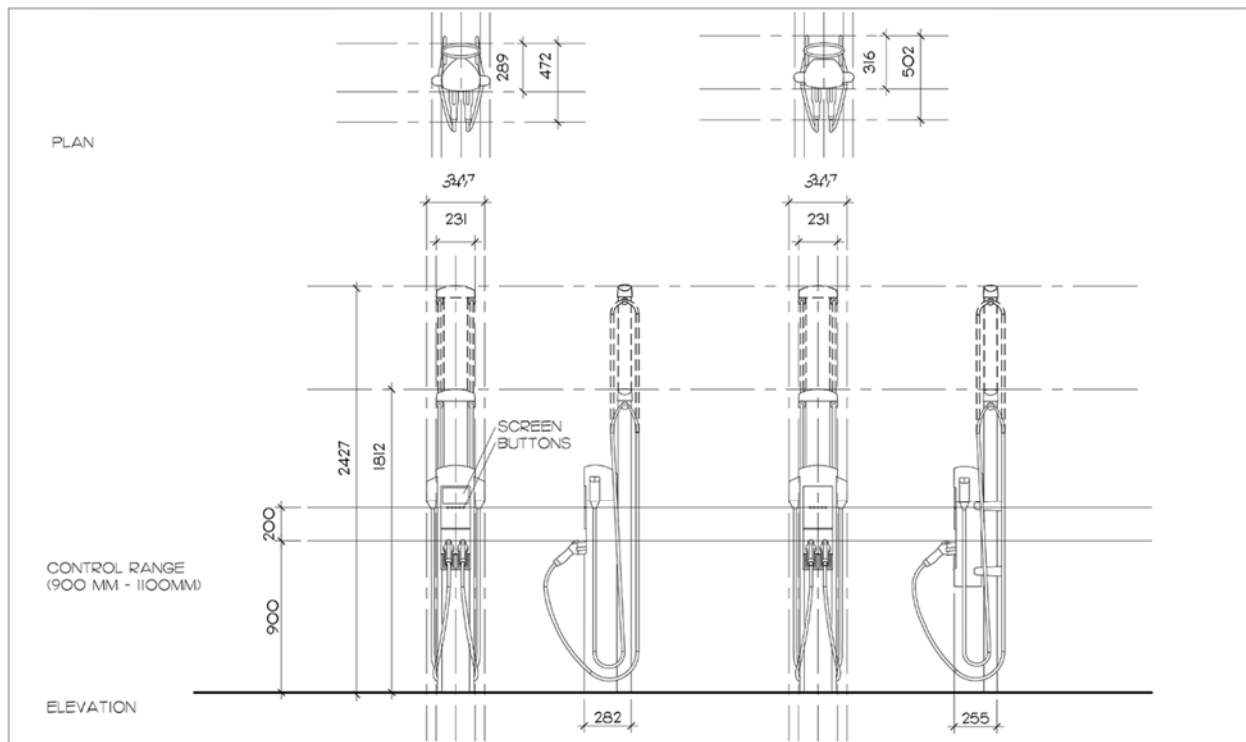

Figure 31: EV Charging Stations (EVCS)

3.3 Passenger Loading Zones

Rationale

Passenger loading zones are important features for all staff and public users but especially for individuals who may have difficulty in walking distances or those who use parallel transit systems. Accessible transit vehicles typically require space for the deployment of lifts or ramps and overhead clearances. Protection from the elements will be beneficial to all and particularly those that may require more time to get into or out of vehicles.

Application

This section applies to exterior passenger loading and drop-off zones where passengers transfer from vehicles to a pedestrian area which provides an accessible route to a facility.

Transit stops, shelters and related amenities are not classified as part of passenger loading zones.

3.3.1 Design and Layout

- a. locate the Passenger Loading Zone (P.L.Z.) as close as possible to the nearest accessible entrance or within 30 metres (maximum);
- b. locate the P.L.Z. away from any traffic flow and design so that users avoid entering any adjacent vehicular routes and drive aisles;
- c. where practical, provide overhead protection (e.g. a canopy to protect users from weather conditions) with clearance (i.e. vertical dimension) of 3600 mm (minimum) throughout vehicular pull-up space and passenger loading zone;
- d. include a side access aisle that (Figure 32):
 - i. is adjacent, parallel and at the same level as the vehicular pull-up space;
 - ii. is 2440 mm wide by 7400 mm long (minimum);
 - iii. provides a clearance height of 3600 mm (minimum) at the vehicle pull-up space and along the vehicle access and egress routes; and

Durham Accessibility and Inclusivity Requirements

April 8, 2022

- iv. provides diagonal pavement markings (e.g. white colour and are clearly visible through use of high tonal contrast compared to surface), extending the full length of the space;
- e. provide bollards between access aisle and vehicular pull-up space;
- f. provide at least one curb ramp for users of mobility aids where there is a change in level; and
- g. where the accessible route and the access aisle are not separated by a curb, install tactile walking surface indicators (TWSIs). When using TWSIs, ensure that they:
 - i. are detectable by foot or cane;
 - ii. are clearly visible through the use of high tonal contrast compared to adjacent mounting surface; and
 - iii. extend across the full length of the space.

3.3.2 Vertical Signage

- a. mark with the International Symbol of Accessibility to formally designate passenger loading and drop-off zones;
- b. ensure size of 300 mm wide by 450 mm high (minimum) (Figure 33);
- c. mount at height of 1500 mm to 2500 mm (centre) (e.g. wall or post-mounted), from ground/floor; and
- d. provide information text, compliant with City By-law requirements (e.g. "Accessible Loading Zone").

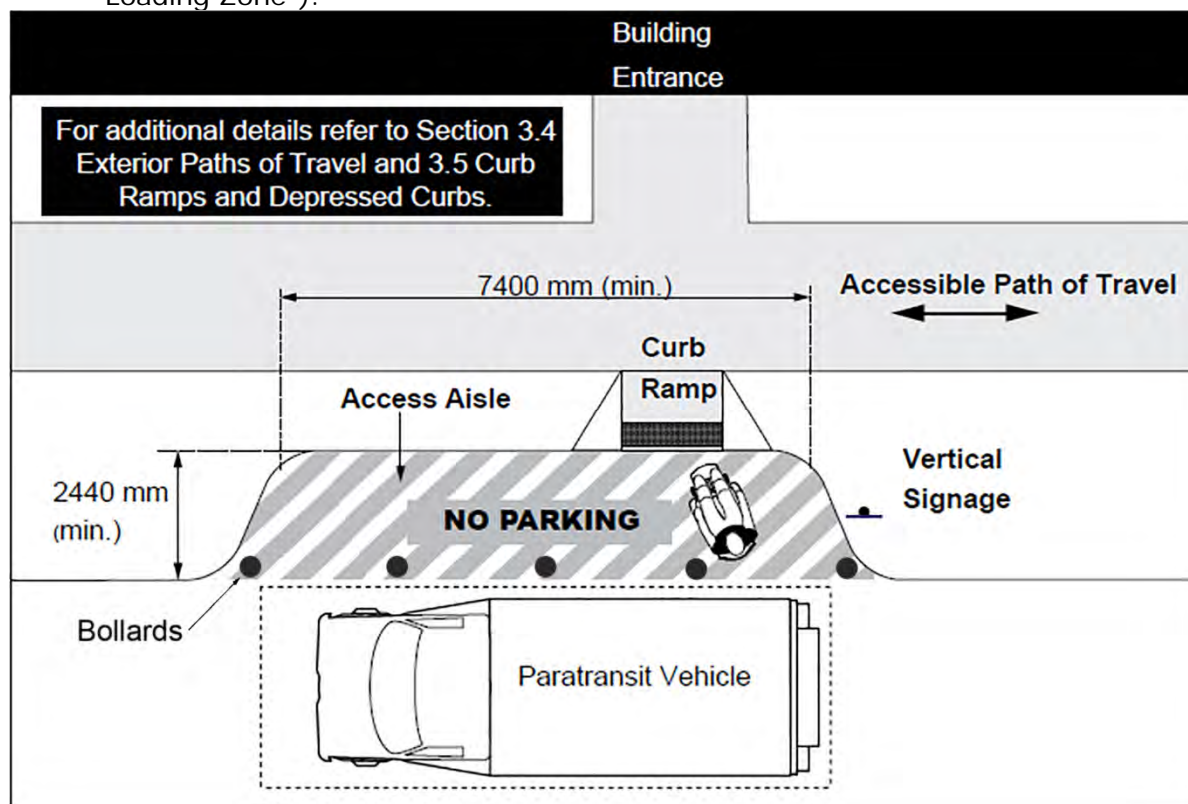

Figure 32: Passenger Loading Zone - Plan View

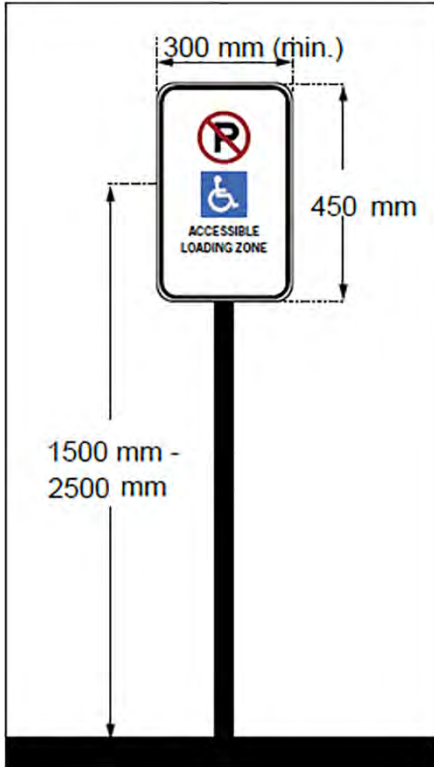

Figure 33: Accessible Loading Zone Vertical Signage

Durham Accessibility and Inclusivity Requirements

April 8, 2022

3.4 Exterior Path of Travel

Rationale

Exterior paths of travel are to address the full range of staff and public. They must provide the clear width, turning and passing spaces necessary for everyone including people who use mobility assistive devices including wheelchairs or scooters, strollers or those travelling in pairs. It is important that the slope and cross slope be minimal to allow for adequate drainage but not create a tipping hazard anywhere along the route.

High colour and tonal contrasts and tactile walking surface indicators set into floors will be important to assist for those who are blind or have vision loss to independently negotiate an environment especially wide-open spaces such as plazas. A contrasting surface adjacent to the accessible route may be accomplished by landscaping features such as grass or alternative textured material. Consider locating all planting and accessible street furniture in an amenity zone, adjacent to the walkway, and using a different tone or material to emphasize the difference in function of the amenity zone.

Edge protection that guards any change in level immediately adjacent to an exterior path is an important safety feature for all users.

Application

This section applies to exterior paths of travel, which typically include, but are not limited to:

- pedestrian circulation routes that serve as connection between the property line / site boundary of a facility, or at facility entrances, exits, elements or amenities
- ramps; and
- curb ramps.

This section applies to walkways used for pedestrian travel and not to provide a recreational experience.

3.4.1 General Features

- a. ensure ground surfaces are firm, stable and slip-resistant;
- b. provide adequate drainage to prevent water accumulation;
- c. ensure headroom clearance is not less than 2100 mm;
- d. provide lighting in accordance with Section 5.7 Lighting requirements, as applicable;
- e. provide a high tonal or textural contrast on ground surfaces to help define primary accessible routes and assist with wayfinding;
- f. where a pedestrian route crosses or joins a vehicular route and the walking surfaces are not separated by curbs, railings or other elements between the pedestrian and vehicular areas, provide tactile walking surface indicators (TWSI), continuous along the full length of the crossing boundary; and
- g. consider providing level rest areas and stopping places along the path of travel, especially sloped walkways longer than 30 metres, for users of mobility aids and people with reduced stamina (Figure 34c).

3.4.2 Clear Width

- a. provide clear width of 1800 mm (minimum) (Figure 34a);
- b. where possible, provide clear width of 2000 mm (minimum) to provide space for a companion or service animal, and more space for passing;
- c. where the clear width of exterior paths of travel is less than 1800 mm (minimum), provide a passing area, 1800 mm wide by 1800 mm long (minimum) at intervals of 30 metres or less (Figure 34b);
- d. where passing areas are provided, ensure they are not considered to be part of any rest area that may also be provided; and
- e. ensure the entrance to exterior paths of travel provide a clear opening of 950 mm (minimum), whether the entrance includes a gate, bollard or other entrance design.

Durham Accessibility and Inclusivity Requirements

April 8, 2022

3.4.3 Running and Cross Slopes

3.4.3.1 Running Slope

Exterior walks that form part of an accessible path of travel under the jurisdiction of Ontario's Building Code must be designed as a ramp where the gradient is greater than 1:20 (5%). Curb ramps are exempt from this requirement.

- a. maximum running slope is 1:20 (5%) (Figure 35a); and
- b. where the exterior path of travel is a walkway, a running slope greater than 1:20 (5%) is allowed but it cannot be steeper than the slope of the adjacent roadway.

3.4.3.2 Cross Slope

- a. provide a maximum cross slope of:
 - i. 1:50 (2%), where the surface is asphalt, concrete or some other hard surface (Figure 35b).

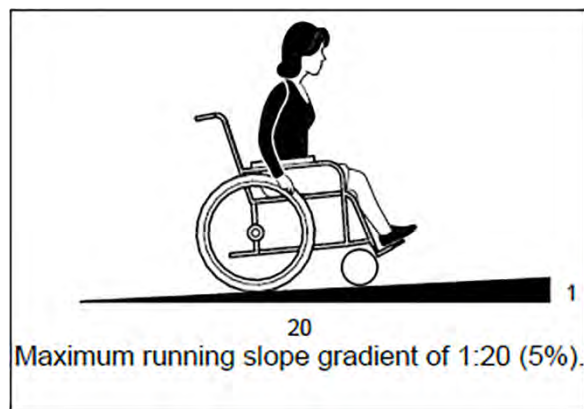

Figure 35a: Running Slope

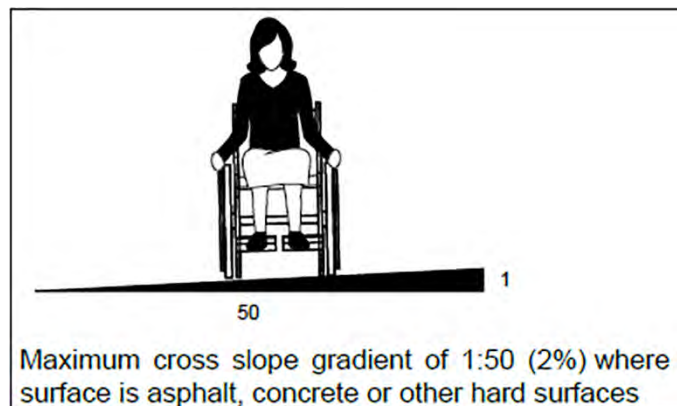

Figure 35b: Cross-Slope

3.4.4 Changes in Level

- a. where there is a change in level along the exterior path of travel, ensure slope requirements are provided in accordance to Table 4:
- b. where there is a change in level or drop-off immediately adjacent to the accessible path of travel,
 - i. provide colour contrasted curb or other barrier protection, 50 m (minimum) high above path of travel, where change in level is between 200 and 600 mm (Figure 36a);
 - ii. provide guards mounted at 1070 mm (minimum), measured vertically to the top of the guard from the ground surface, where change in level is more than 600 mm or where the adjacent surface within 1200 mm from the accessible route has a slope of more than 1:2 (Figure 36c);
 - iii. guards are not required if the slope of the surface adjacent to the accessible route is not steeper than 1:2 within 1200 mm from the accessible route (Figure 36b); and
- c. ensure curb or other type of barrier protection is designed to allow surface drainage.

Table 4: Change in Level - Slope Requirements

| Change in Level (height) | Slope Requirements |
|--------------------------|----------------------------------------------------|
| 1-5 mm | No bevel required |
| 6-13 mm | 1:2 bevel |
| 14-74 mm | maximum running slope 1:8 (12.5%) or add curb ramp |
| 75-200 mm | maximum running slope 1:10 (10%) or add curb ramp |
| More than 200 mm | add a ramp |

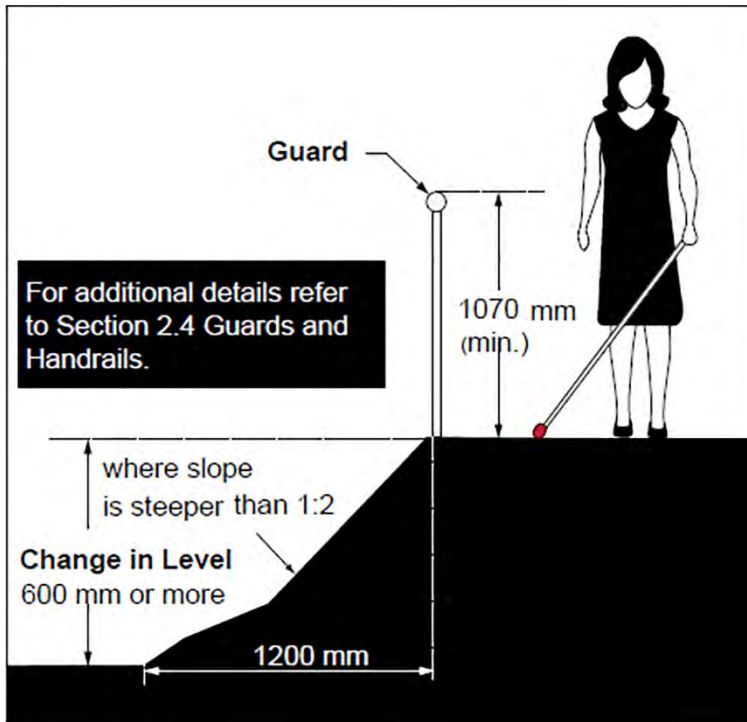

Figure 36c: Guard - Change in level more than 600 mm or where the slope of the adjacent surface within 1200 mm from the accessible path of travel is greater than 1:2

3.4.5 Rest Areas

When constructing new or redeveloping existing exterior paths of travel intended to be maintained, Section 2.6 "Rest Areas" applies.

Durham Accessibility and Inclusivity Requirements

April 8, 2022

3.5 Curb Ramps and Depressed Curbs

Rationale

Curb ramps or curb cut and depressed curbs help people with disabilities safely and independently seamlessly negotiate level changes along public sidewalks and all other pedestrian routes. The issues related to the slopes of ramps also apply equally to slopes of curb ramps. A well-designed curb ramp will be unusable if there are any uneven or gapped transition between the road surface and curb ramp. Flared sides on the curb ramp, which are not considered part of the accessible path of travel, help eliminate the hazard of pedestrians stepping off of an abrupt edge. While a smooth transition and minimal slope are ideal for someone using a wheeled assistive mobility device, tactile attention indicators are required at these locations for those who are blind or have vision loss to mark the transition from safe pedestrian area to the driveway or street.

Application

Curb ramps and depressed curbs are required when there is a change in level between an exterior path of travel and adjacent vehicular route.

“Curb ramp” means a ramp that is cut through a curb at a roadway and slopes up to a sidewalk. Types are usually categorized by their structural design and how they are positioned relative to the sidewalk and roadway.

- perpendicular - one that is aligned so that the ramp is generally perpendicular to the centreline of the roadway, and users will generally be travelling perpendicular to traffic when they enter the street at the bottom;
- parallel - one that has two ramps leading towards a centre level landing at the bottom; and
- combination of perpendicular and parallel.

“Depressed curb” means a seamless gradual slope at transitions between sidewalks and walkways and highways, and is usually found at intersections. Corners where the depressed curb continues from one crosswalk, around the corner radius, and through the next crosswalk are also called “depressed corners”.

The provision of curb ramps and depressed curbs ensures a continuous accessible path of travel between vehicular and pedestrian routes, for the following typical locations:

- pedestrian crossings at intersections
- parking spaces, passenger loading zones and related access aisles; and
- any other exterior pedestrian route where there are elevation changes.

The choice between providing a curb ramp or a depressed curb depends on physical characteristics, volume of pedestrian traffic and space availability. The flared sides of the curb ramps provide additional directional assistance, however, having a raised curb between curb ramps may not be suitable to high pedestrian traffic locations, or possible due to intersection geometry, and therefore a depressed curb may be chosen. It can be very difficult for people with visual disabilities to orient themselves relative to the crosswalks at very large depressed corners. Instead of a fully depressed corner, consider providing a full height curb around the corner radius with appropriate transitions from the separate depressed curbs or curb ramps at each crosswalk. Landings shall be permitted to overlap other landings and clear space.

3.5.1 Design and Layout

- a. ensure surface is stable, firm and slip-resistant;
- b. ensure curb ramp or depressed curb is aligned with the direction of travel (e.g. crosswalks) and curb ramp or depressed curb on the opposite side of the roadway to help users orient themselves and to allow someone to maintain a straight line of travel;
- c. design to provide suitable drainage, to prevent water, snow and ice accumulation within the accessible path of travel; and

Durham Accessibility and Inclusivity Requirements

April 8, 2022

- d. ensure gratings and other openings are not placed on curb ramps, depressed curb or within pedestrian crossings.

3.5.2 Width

- a. provide clear width of 1500 mm (minimum), exclusive of flared sides (Figure 37);
- b. where the width of the sidewalk is greater than 1500 mm, provide curb ramp with the same width as the sidewalk, exclusive of flared sides; and
- c. for depressed corners, the length of the depressed curb is dependent on the width of the sidewalks and the corner radius, but should be no less than 3300 mm.

3.5.3 Running and Cross Slopes

- a. ensure maximum running slope of 1:12 (8%) for curb ramps, depressed curbs/corners; and
- b. ensure maximum cross slope of 1:50 (2%).

3.5.4 Flared Sides

Where curb ramps are provided, they shall have flared sides:

- a. ensure surface is stable, firm, slip-resistant and non-glare;
- b. ensure the sides are clearly demarcated with grooved edges; and
- c. provide a slope gradient between 1:15 (6.7%) and 1:10 (10%), measured parallel to the curb line (Figure 34).

3.5.5 Landing

- a. ensure a level landing 1200 mm by 1200 mm (minimum) is provided at the top of the curb ramp;
- b. where possible, provide a level landing of 2440 mm by 2440 mm or more at the top of the curb ramp to accommodate larger wheeled mobility aids;
- c. provide an additional landing if users must change direction while using the curb ramp;
- d. ensure running and cross slopes are 1:50 (2%) (maximum); and
- e. landings are not required at depressed curbs since the associated shallow slope will be sufficient.

3.5.6 Tactile Walking Surface Indicator (TWSI)

Where curb ramps or depressed curbs are provided on an exterior path of travel, provide tactile walking surface indicators in accordance with Section 2.7 Tactile Walking Surface Indicators" and also the following:

- a. are installed at the bottom portion of the curb ramp or depressed curb, set back 150 to 200 mm from the back edge of the curb, and following any curvature in the curb;
- b. are installed in concrete and with a minimum 150 mm concrete border around the TWSI for locations within a non-concrete sidewalk or walkway;
- c. concrete border width around TWSI may be increased and adjusted to suit corner geometry;
- d. are installed with the tops of the domes level with the adjacent concrete surface;
- e. have a minimum depth of 610 mm;
- f. for curb ramps, ensure TWSI extend along the full width of the curb ramp (Figure 38);
- g. for depressed curbs, ensure TWSI extend along the bottom portion of the depressed curb that is flush with the roadway, and to a minimum width of 1500 mm; and
- h. for depressed corners where two pedestrian crossings are provided, ensure the TWSI extend around the corner wherever the bottom portion of the curb is flush with the roadway, providing a 300 mm space (gap) in the TWSI located at the junction where the two crossings meet (Figure 39).

April 8, 2022

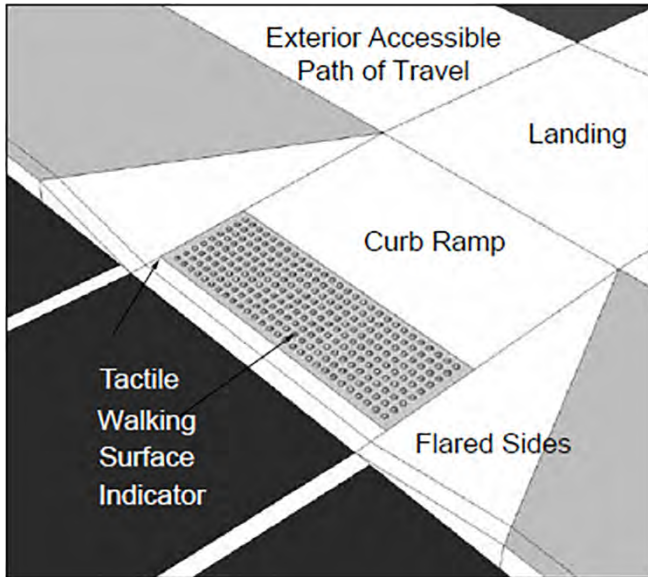

Figure 37: Typical Curb Ramp

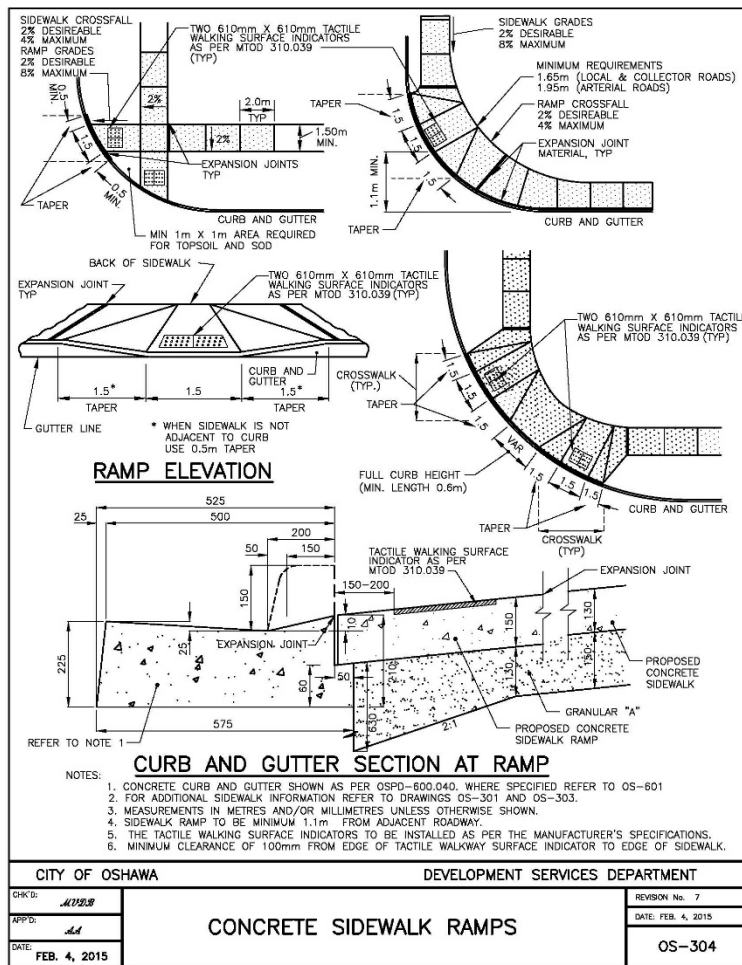

Figure 38: Typical Curb Ramp Design

Durham Accessibility and Inclusivity Requirements

April 8, 2022

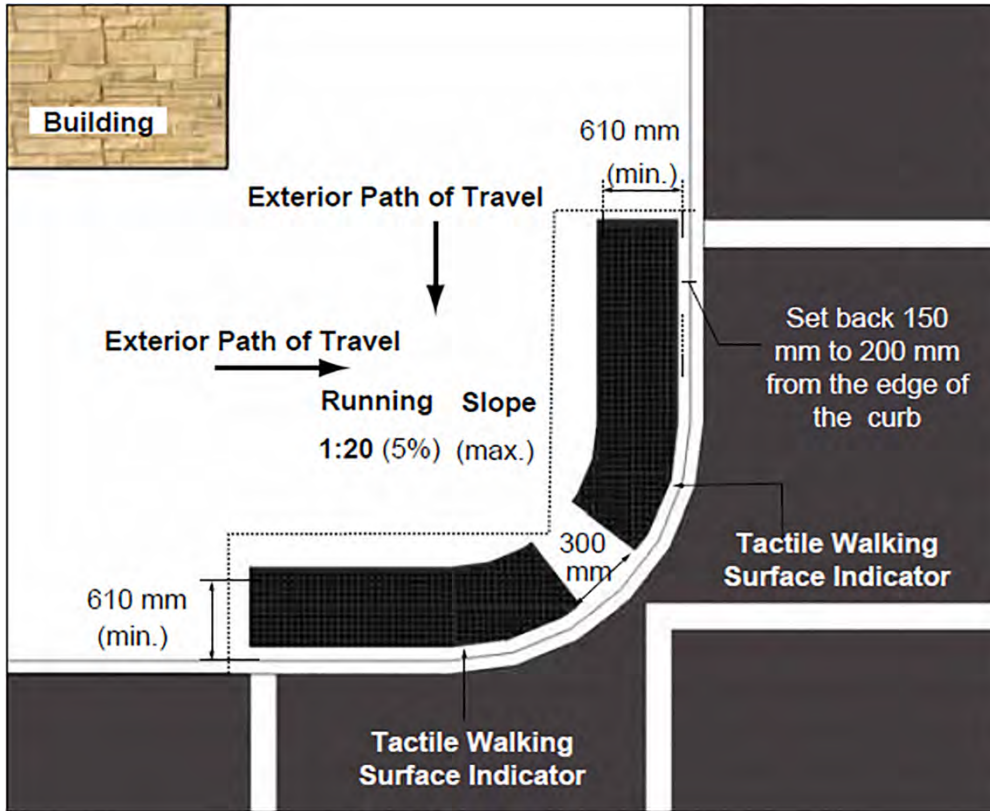

Figure 39: Typical Depressed Corner Design - Plan View

Durham Accessibility and Inclusivity Requirements

April 8, 2022

4.0 Interior Environments

4.1 Entrances

Rationale

Design decisions concerning all staff and public entrances will have an immediate impact on the independence and dignity of everyone entering a facility. Entrances that address the full range of individuals using the facility support the goals of inclusion that separate accessible entrances do not. Entrances to the building include those from underground parking or from other exterior amenities, not just the main front entry door.

Features such as canopies can limit the influence of weather conditions on this already busy area and also make an entrance more obvious to a person with a cognitive disability or someone unfamiliar with the facility.

Application

This section applies to pedestrian entrances into facilities. Entrances include all access and entry points into a facility. Where several doors are provided adjacent to each other (e.g. a bank of doors), these doors are considered a single entrance. An entrance typically consists of several elements and includes the approach and route leading to a facility, the components of the entrance itself and transition area between exterior and interior environments (e.g. vestibule). It may also include an interior lobby or waiting area, where applicable.

4.1.1 Provision

- a. at least one main or primary entrance into a facility is required to be accessible (e.g. via level, sloped or ramped accessible routes);
- b. at least 50% of the total number of building entrances are required to be accessible, rounding up to the nearest whole number; and
- c. locate entrance no more than 30 metres away from designated accessible parking or passenger loading or drop-off zones.

4.1.2 Main or Primary Entrance Features

Where an entrance is designated as a main or primary accessible entrance into a facility:

- a. locate as part of an accessible path of travel, including exterior level landing area of 2440 mm by 2440 mm (minimum);
- b. provide power door operator and mark door with International Symbol of Accessibility (Figure 40);
- c. consider providing automatic sliding doors at highly used entrances;
- d. provide directional signage at strategic points to guide users from accessible parking areas, drop-off and loading zones, and site access points to the accessible entrance;
- e. where an entrance is not accessible, provide directional and informational signage to identify location of the closest accessible entrance;
- f. ensure clear door width of 950 mm (minimum);
- g. where an entrance vestibule is provided, ensure:
 - i. the distance between the two doors in series is 1500 mm (minimum), plus the width of the door swinging into the space; or
 - ii. a turning space of 1500 mm (minimum) diameter is provided where doors do not align;
 - iii. power door operators are provided on both doors; and
- h. where overhead protection (e.g. canopy) at pedestrian entrance and passenger loading or drop-off zones adjacent to the entrance is provided, ensure the height clearance is 2750 mm (minimum) or 3600 mm (preferred).

Durham Accessibility and Inclusivity Requirements

April 8, 2022

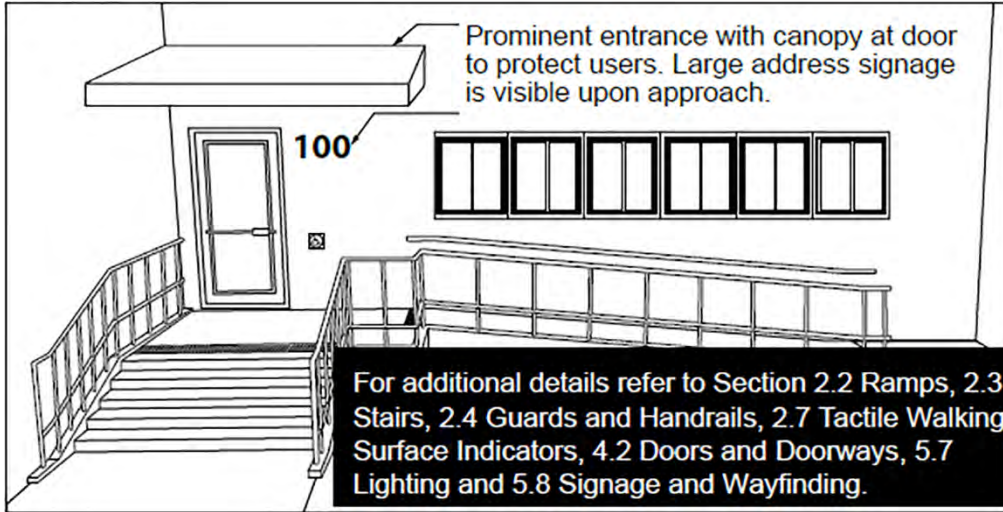

Figure 40: Main or Primary Entrance Features

Durham Accessibility and Inclusivity Requirements

April 8, 2022

4.2 Doors and Doorways

Rationale

Sufficiently wide doorways are advantageous to individuals using wheelchairs or scooters, pushing strollers, people who use guide or service animals, or who are making a delivery. A raised threshold at the base of the door will impede any one of these individuals. This same group, with the addition of children, seniors or even someone carrying packages, will have difficulty opening a heavy door and will benefit from an automated door opener.

Independent use of doors is the goal. Reliance on assistance from others to open doors is not an accessible or appropriate solution.

Careful thought to the direction of the door swing can enhance the usability and limit the hazard to other pedestrians. Sliding doors are often easier for most individuals to operate, and typically require less mobility assistive device manoeuvring space. Doors that require two hands to operate are not considered to be accessible. Revolving doors are not accessible for people using mobility assistive devices and strollers or for those with some sensory disabilities or claustrophobia. Also, the coordination required to use such doors may be difficult for children or a person with a cognitive disability.

Frameless and fully glazed doors present a hazard to everyone and especially for those who are not paying attention or who are blind or have vision loss. This makes the inclusion of high colour and tonal contrasting strips across the glass, mounted at eye level, as well as colour and tonally contrasting door frames and door hardware, an important safety and visibility feature for glazed doors.

Application

This section applies to all interior and exterior doors along an accessible route, intended for staff and public use, which lead into, out of and through a facility. The provision of accessible doors as part of an accessible route is an important consideration for all users of a facility.

Where doors have more than one independently operated leaf (e.g. at a bank of doors), at least one of the door leaf's is required to be accessible, meeting the criteria identified in this section.

Additional considerations are required to address issues related to doors used for fire and life safety (e.g. use of electro-magnetic 'hold-open' devices and door closer adjustments).

4.2.1 Clear Width

For interior and exterior doors and doorways along an accessible route:

- a. provide a clear width of 950 mm (minimum), measured when the door is open 90 degrees from the face of door (and/or exit door hardware that projects into the path of travel) and the opposite door stop (Figure 41). The use of offset door hinges to provide the required clear width for some existing doors may be a feasible option or consideration.

Durham Accessibility and Inclusivity Requirements

April 8, 2022

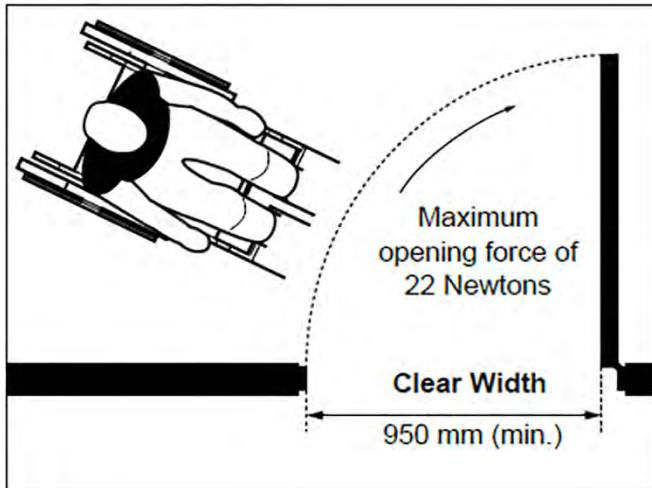

Figure 41: Clear Width of Doors - Plan and elevation Views

4.2.2 Opening Force and Closers

4.2.2.1 Opening Force

The maximum opening force required for push / pull is:

- 38 Newtons (8.5 pounds) for exterior hinged doors;
- 22 Newtons (5 pounds) for interior hinged doors; and
- 22 Newtons (5 pounds) for sliding or folding doors.

4.2.2.2 Closers

- adjust closers so that from an open position of 90 degrees, the time required to move the door to a position of 12 degrees from the latch is 5 seconds (minimum).

4.2.3 Tonal Contrast of Doors and Frames

- provide high tonal contrast to differentiate doors and / or door frames from the surrounding environment.

Exception: Tonal contrast is not required at service doors (e.g. electrical room, maintenance room, janitor room).

4.2.4 Thresholds

- provide bevel at maximum slope of 1:2 (50%), where transition is between 6 mm and 13 mm high;
- ensure threshold at door is not more than 13 mm high;
- installation of door kick plates is preferred, mounted 300 mm high, measured from bottom edge of door, covering the entire width of the door, especially within high traffic areas.

4.2.5 Door Hardware

Door hardware includes, but is not limited to, handles, pulls, latches and locks, with the following features:

- mount between 900 mm (minimum) and 1100 mm (maximum) high from finished floor or ground surface;
- hardware must be usable with closed fist and operable with one hand;
- ensure tight grasping of hands, pinching of fingers or twisting of wrists are not required to operate hardware (e.g. knob hardware and thumb-latch handles);
- where sliding doors are provided, ensure operating hardware is usable on both sides when the door is in the open position (e. g. large D-pull handles); and
- ensure high tonal contrast hardware finishes are provided when compared to mounting surface.

Durham Accessibility and Inclusivity Requirements

April 8, 2022

4.2.6 Revolving Doors and Turnstiles

- revolving doors and turnstiles are not accessible options, and shall not be the only means of passage at an accessible entrance or along an accessible route;
- provide accessible gate or door adjacent to turnstiles and / or revolving door, with clear width of 950 mm (minimum) (Figure 42);
- ensure accessible gate or door is clearly marked with International Symbol of Accessibility; and
- where draft control is a concern at entrances, consider the use of air curtains or other systems to minimize ingress of cold/warm exterior air.

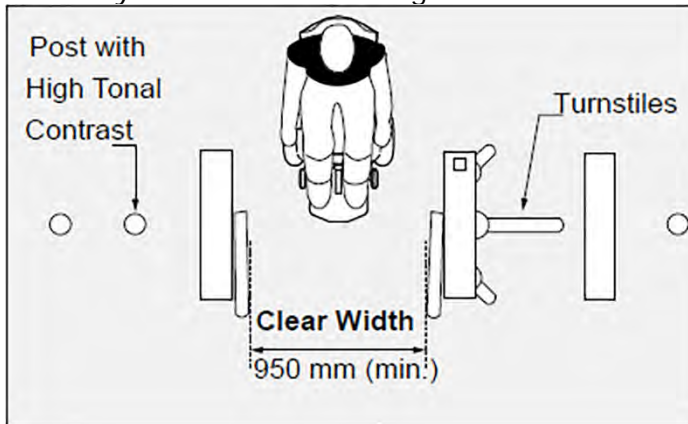

Figure 42: Accessible Controlled Gate

4.2.7 Automatic Doors

Where automatic doors are provided, which are sliding or swinging doors activated by infrared sensors:

- ensure sensors are suitably placed to detect users approaching; and
- ensure timing allows safe passage through doors.

4.2.8 Power-Assisted Doors

Power-assisted doors have two different types of operation:

- automatically activated by a motion detector or a floor pad sensor; and
- manually activated by pushing a control.

Doors that open automatically are considered a preferred option where possible, since they do not require manual activation and address the needs of a wide range of users. This recognizes that manual power-assist controls may be difficult to locate and activate for people with limited vision, strength, manual dexterity, reach or users that may have multiple types of disabilities. A vertical extended power door operator can accommodate a wider range of users (e.g. can be operated by service animals, foot or foot rest) as it allows activation from any approach and height level (Figures 43 and 44b). Power door operators can be mounted on a wall or a pedestal to ensure proper location and ease of use. Power-assisted swing doors that are activated by pushing a control are required at the main entrance(s) and accessible washrooms of a facility. For main entrances to larger facilities with high-occupancy load, an automatic sliding door system is recommended to control the flow of pedestrian traffic and facilitate access for the majority of users.

Based on the overall design, the level of use of interior spaces and where swing doors are provided throughout a facility, power-assisted swing doors that are activated by pushing a control are also commonly provided at:

- interior doors along accessible routes and / or connecting accessible routes;
- doors into reception areas;

Durham Accessibility and Inclusivity Requirements

April 8, 2022

- doors into highly used functional spaces (e.g., larger multi-purpose rooms, meeting or board rooms); and
- doors leading to accessible exits and designated "Areas of Refuge".

Consider providing roughed in power for future power door operators at other locations.

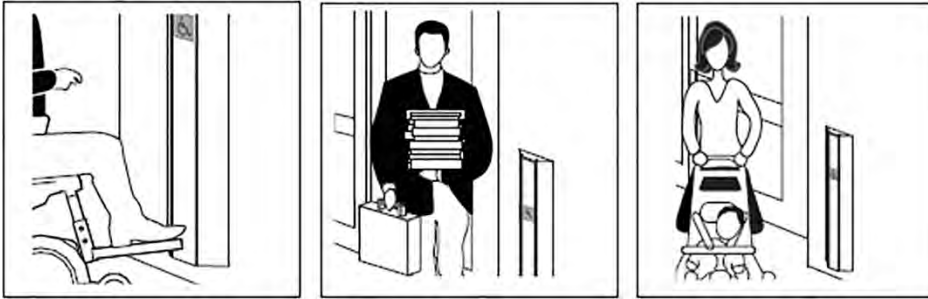

Figure 43: Example of Control for Power Door Operator Promoting Universal Use

Where power-assisted swing doors activated by pushing a control are provided:

- a. mark accessible doors with International Symbol of Accessibility and other signage (e.g. "Caution" decals to warn of door swing);
- b. ensure a force of no more than 66 Newtons is required to stop door movement;
- c. in case of power failure, ensure power-assisted doors can be opened manually;
- d. ensure door remains fully open for 5 seconds (minimum);
- e. ensure doors take not less than 3 seconds (minimum) to move from a closed to fully open position, when activated;
- f. where power-assisted doors are activated by proximity card reader devices, ensure timing of door opening is synchronized with operation of proximity device; and
- g. provide power door operator controls on both sides of doors, for use when entering or leaving, with the following criteria:
 - i. mount in clearly visible location or easy identification upon approach from either direction of travel;
 - ii. ensure the dimension of the power door operator control is 150 mm (minimum) in diameter where it is circular or 150 mm wide by 915 mm long (minimum) where it is a vertical extended power door operator;
 - iii. in a retrofit situation, where standard control sizes will not fit, provide a rectangular shaped power door operator control with dimensions of 50 mm by 100 mm;
 - iv. ensure high tonal contrast is provided between power door operator control and mounting surface;
 - v. ensure they project less than 100 mm from mounting surfaces;
 - vi. mark with International Symbol of Accessibility;
 - vii. ensure controls are operable with a closed fist;
 - viii. mount at height of 900 mm to 1100 mm from ground or floor surface (Figure 44c);
 - ix. where rectangular extended power door operator controls are provided, mount so that they extend from not more than 200 mm and not less than 900 mm high above the floor (Figure 44b);
 - x. mount between 600 mm and 1500 mm, on a level wall surface or separate post, beyond the door swing where the door opens towards the control (Figure 44a); and
 - xi. provide a minimum clear floor space of 1675 mm by 1675 mm in front of power door operator control.

Durham Accessibility and Inclusivity Requirements

April 8, 2022

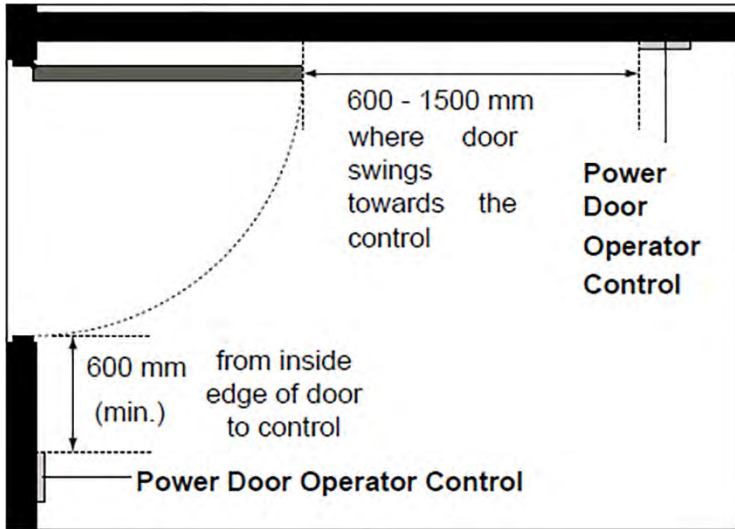

Figure 44a: Power Door Operator Control Mounting Location - Plan View

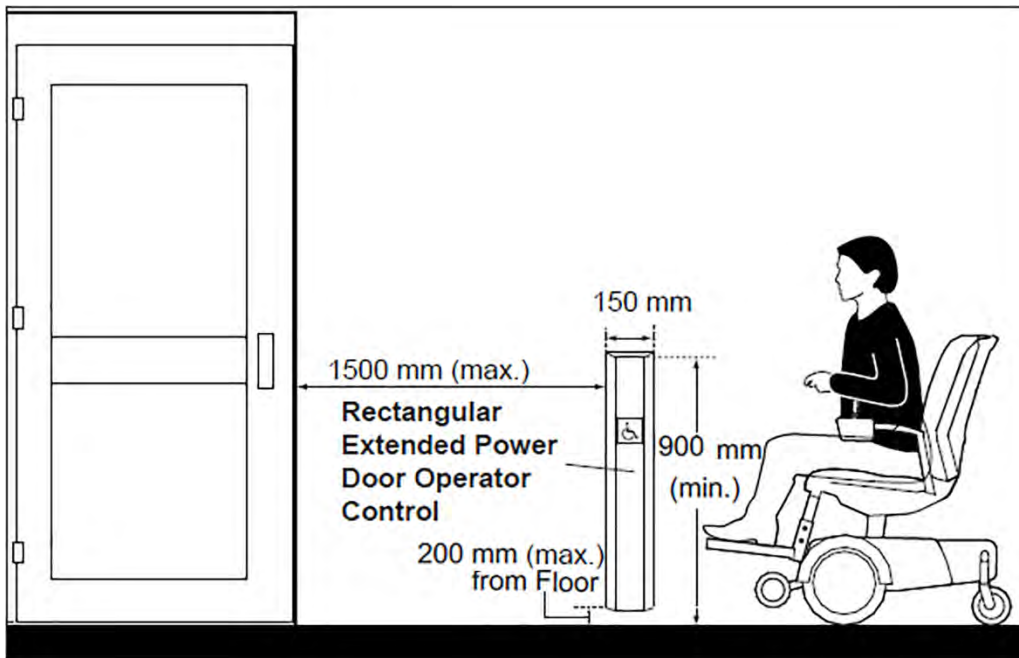

Figure 44b: Vertical Extended Power Door Operator - Elevation View

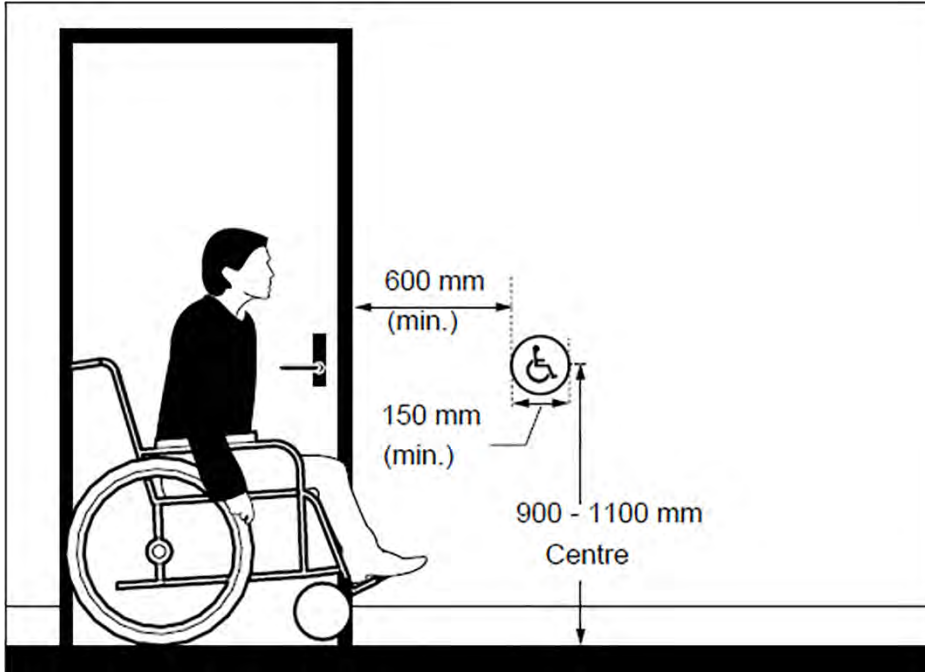

Figure 44c: Circular Power Door Operator Control - Elevation View

4.2.9 Doors swinging into Accessible Routes

Where automatic or power-assisted doors, whether activated by a control manually or automatically by a motion sensor or a floor-pad sensor that someone steps on (e.g., typically used at higher traffic doors), swing into an accessible path of travel:

- a. provision of recessed doors is preferred (Figure 45); or
- b. for swinging doors opening into passing pedestrian traffic, provide cane detectable guards or other devices at right angles to the wall containing the door, with the lower rail surface mounted no more than 680 mm high (maximum) from ground or floor surface, extending 300 mm (minimum) beyond the door swing, on both sides of doors (Figure 46). Swinging doors equipped with power operators which are activated automatically and open into passing pedestrian traffic should also have a device (mat or other sensor) on the swing side to prevent the door from opening if someone is standing in the swing area.

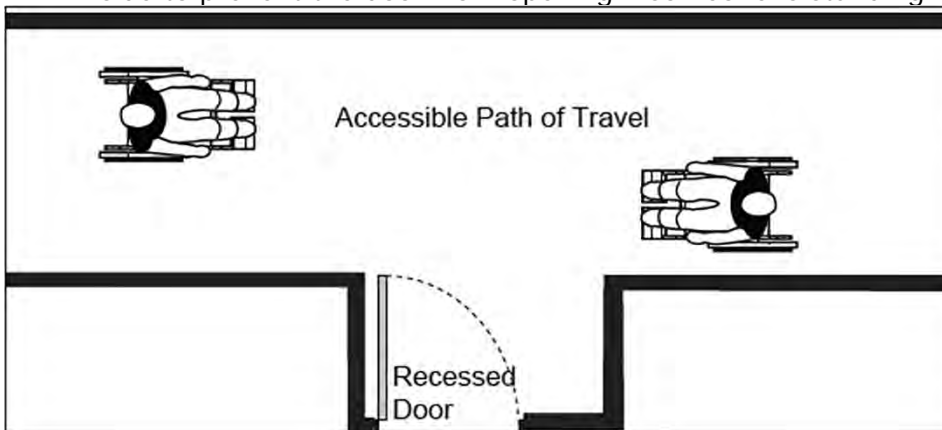

Figure 45: Recessed Door - Plan View

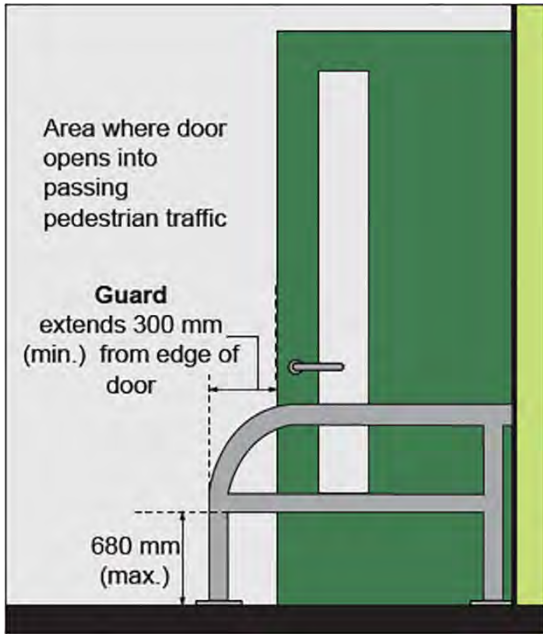

Figure 46: Guard at Door - Elevation View

4.2.10 Approach Clearances at Doors

The floor space requirements at swinging doors are dependent on how doors are approached (e.g. side or front) and on which side an individual approaches a door (push or pull sides). Clear floor space requirements for approach at different types of doors are summarized in Table 5 with corresponding diagrams referenced.

Table 5: Minimum Clearance at Doors

| Context | Floor Space Required in mm | | |
|------------------------------------------------------------|----------------------------|------------|--------------------|
| | Depth min. | Width min. | Space Beside Latch |
| Side-Hinged Door – Front Approach (Figure 47c) | | | |
| Pull side | 1525 | 1600 | 600 |
| Push side | 1370 | 1250 | 300 |
| Sliding Door (Figure 47d) | | | |
| Front approach | 1370 | 1100 | 300 |
| Side approach | 1370 | 1550 | 600 |
| Side-Hinged Door – Hinge Side Approach (Figure 47e) | | | |
| Pull side | 1600 | 1600 | 600 |
| Push side | 1370 | 1830 | 450 |
| Side-Hinged Door – Latch Side Approach (Figure 47f) | | | |
| Pull side | 1370 | 1600 | 600 |
| Push side | 1370 | 1525 | 600 |
| Folding Door | | | |
| Front approach | 1220 | n/a | n/a |
| Side approach | 1220 | n/a | n/a |
| Recessed Door – Front Approach (Figure 47a and b) | | | |
| Pull side | 1525 | n/a | 600 |
| Push side | 1220 | n/a | 300 |
| Doorways Without Doors | | | |
| Front approach | 1220 | n/a | n/a |
| Side approach | 1065 | n/a | n/a |

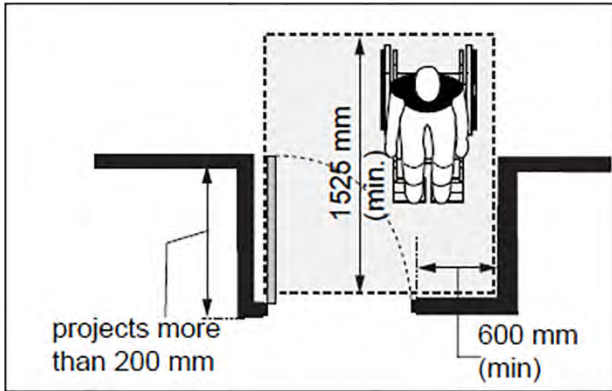

Figure 47a: Pull Side Approach at Recessed Side-Hinged Door - Plan View

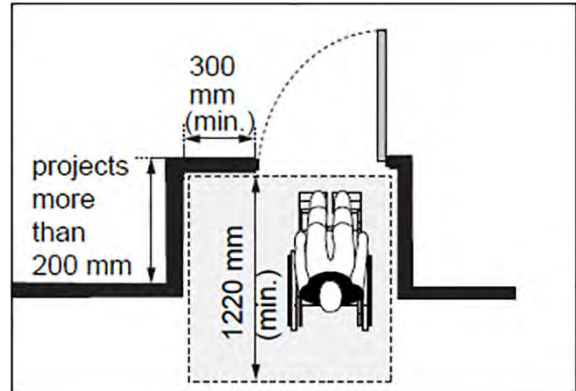

Figure 47b: Push Side Approach at Recessed Side-Hinged Door - Plan View

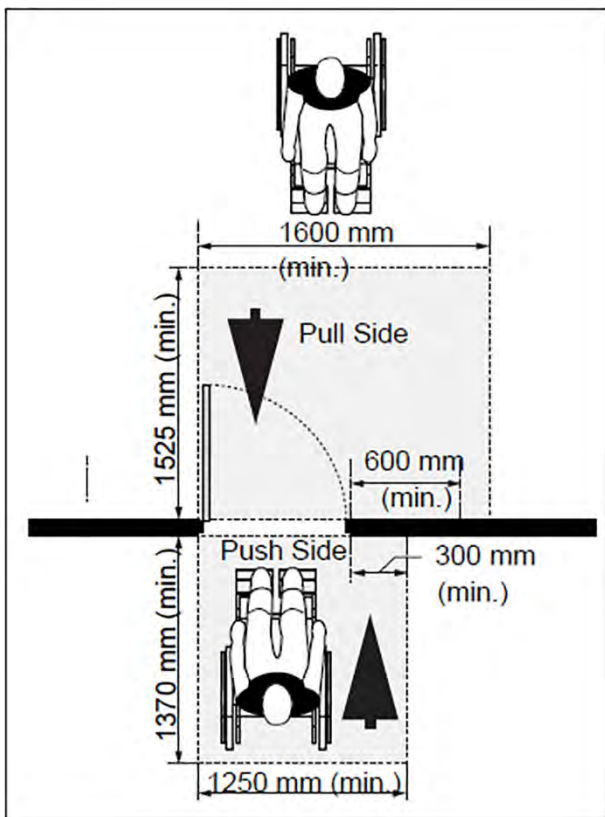

Figure 47c: Front approach at Side-Hinged Door - Plan View

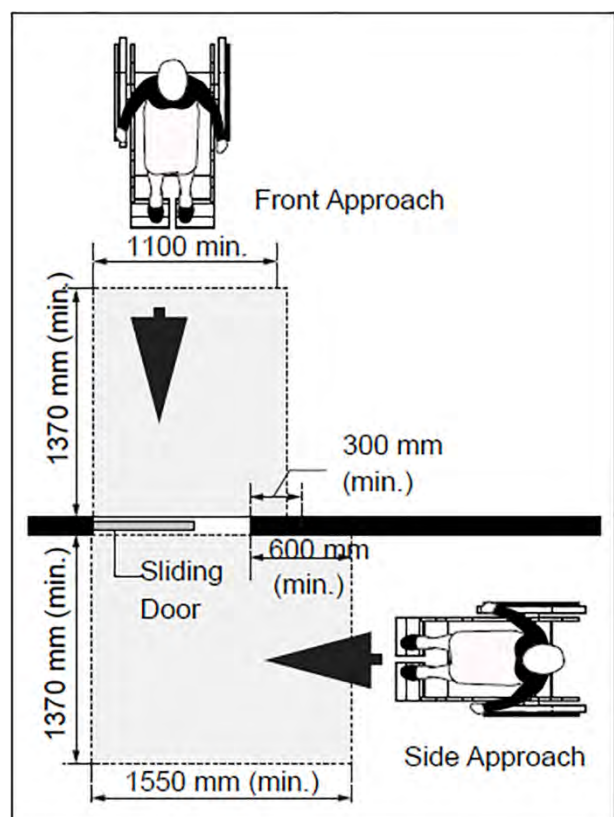

Figure 47d: Front and Side Approach at Sliding Door - Plan View

Durham Accessibility and Inclusivity Requirements

April 8, 2022

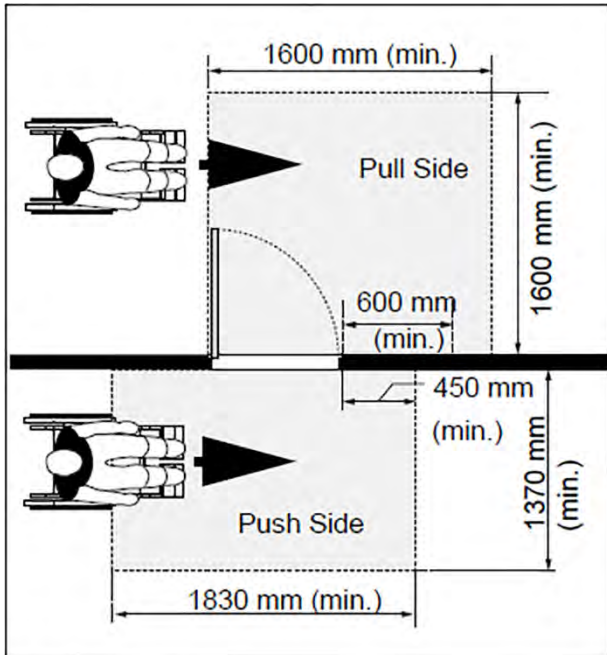

Figure 47e: Hinge Side Approach at Side-Hinged Door - Plan View

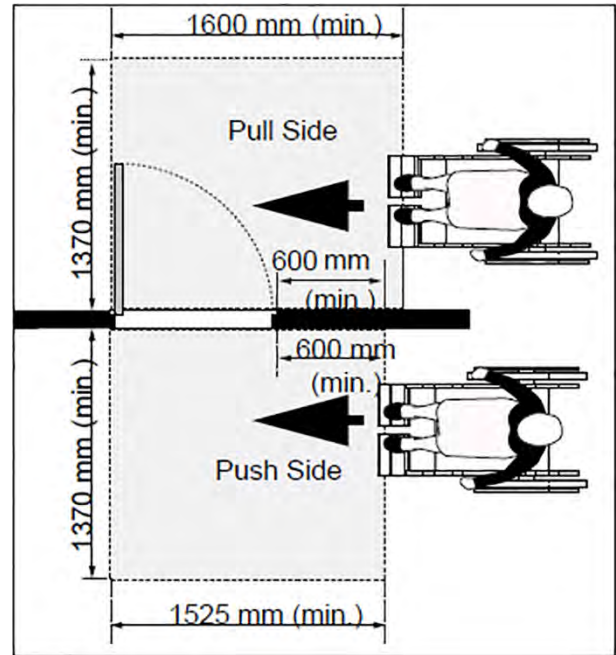

Figure 47f: Latch Side Approach at Side-Hinged Door - Plan View

4.2.11 Doors in Series

Where doors in series form a vestibule:

- provide a distance between two doors in series of 1500 mm (minimum), plus the width of the door swinging into the space (Figure 48);
- where the doors into the vestibule are not aligned, provide a turning diameter of 1500 mm within the vestibule clear of any door swing; arrange vestibule to allow the movement of users of mobility aids without the risk of being stuck between doors;
- provide additional suitable clear floor space (1500 mm minimum turning circle) for users of mobility aids where the vestibule may be used as a waiting area, for example at main entrances; and
- ensure power door operators are provided on both sides of both doors.

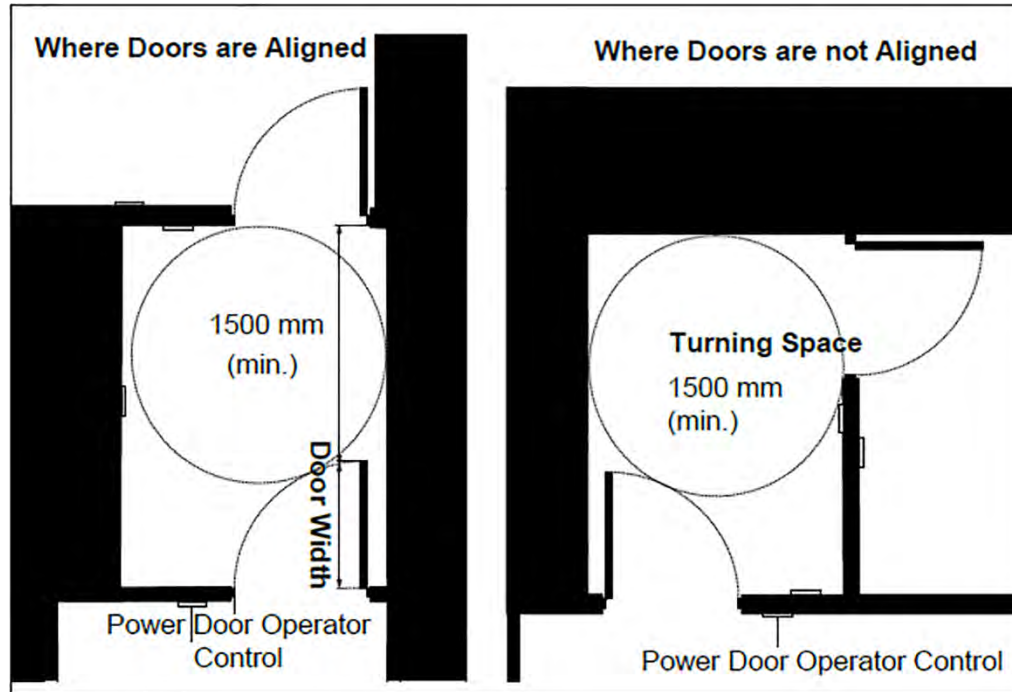

Figure 48: Doors in Series - Plan View

4.2.12 Glazed Doors or Doors with Sidelights

- a. provide a high tonal contrast between door frame and mounting surface or wall to ensure that when door is in the open position, people with vision loss can identify edges upon approach;
- b. mark the edges of fully glazed doors (e.g. tempered glass without frame) with a high tonal contrast (e.g. exposed edges to be identified with vertical safety strip, applied to cap the ends of any exposed glass panel); and
- c. provide a continuous opaque and high tonal contrast strip, decal or logo on fully glazed doors (Figure 49):
 - i. 50 mm (minimum) wide;
 - ii. mount at eye level between 1350 mm (minimum) and 1500 mm (maximum) high from floor level;
 - iii. where there is extensive glazing, consider providing a second strip at a lower level, between 850 mm (minimum) to 1000 mm (maximum) high from floor level; and
 - iv. where special designs are used (e.g logo or symbol), ensure they do not reduce the opacity, width and high tonal contrast of the strip when compared with the background.

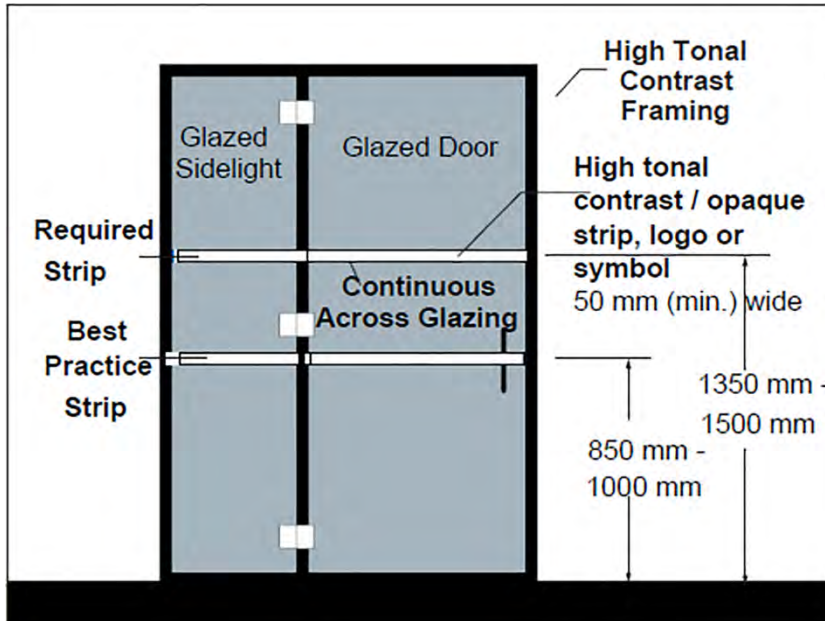

Figure 49: Glazed Doors - Elevation View

4.2.13 Vision Panels

- a. provide width of 75 mm (minimum); and
- b. mount bottom edge at a height of 900 mm (maximum) with side edge no more than 250 mm from latch side of the door (Figure 50).

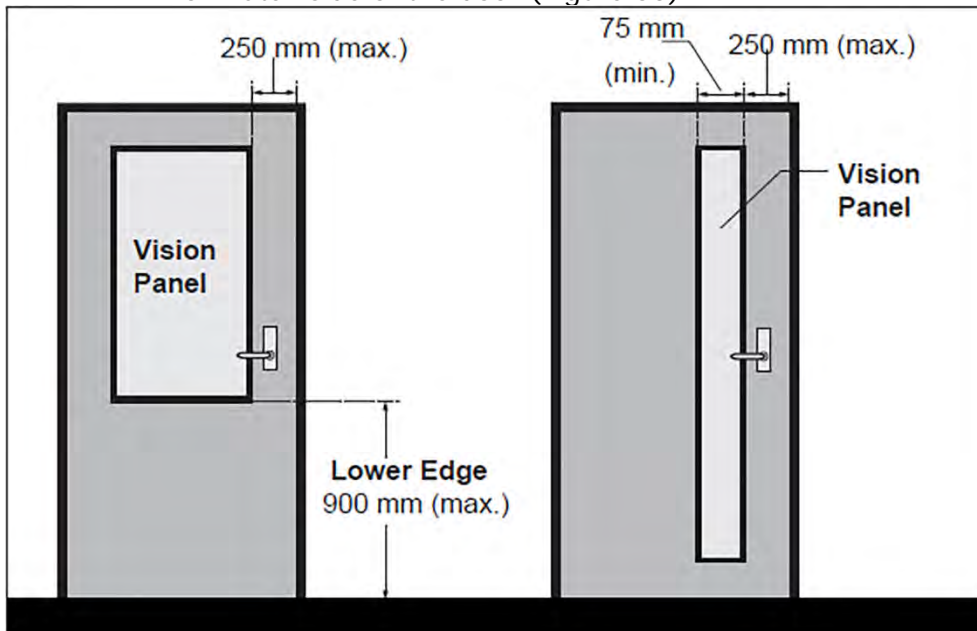

Figure 50: Vision Panels - Elevation View

Durham Accessibility and Inclusivity Requirements

April 8, 2022

4.3 Interior Accessible Routes

Rationale

Routes of travel through a facility need to accommodate the full range of staff and public. They must provide the clear width and turning spaces necessary for people who use mobility assistance devices including wheelchairs and scooters, those pushing strollers, or those travelling in pairs. Consideration is to be given to the width and maneuverability of mobility devices especially at decision points and at doors. While a corridor may be wide enough for a person to drive a scooter in a straight line, it may not be possible to make a turn around or to pass. The preferred minimum width for primary accessible routes is 1800 mm.

High colour and tonal contrasts and in some locations tactile walking surface indicators set into floors will be important to provide to assist for those who are blind or have vision loss to negotiate an environment, especially large open areas like approaching the building or interior lobbies.

Level changes along an accessible route between adjacent surfaces need to be avoided. Where this is not possible, edge protection and other strategies are to be provided as an important safety feature for all users and to ensure continuity of the path.

Application

This section applies to accessible routes or paths of travel for pedestrians within a facility to provide access to elements, rooms or other occupiable spaces. Typical accessible routes are identified as corridors, hallways and other pedestrian circulation paths. These include connections between buildings, unless identified as exceptions. Access to occupiable spaces must be accessible and conform to this section.

Where there is an elevation change within a path of travel, accessible routes may include ramps, sloped walkways and independently operated elevating devices as permitted (e.g. passenger elevators or lifts).

Exception

An accessible route or path of travel is not required in the following areas:

- Service rooms.
- Elevator machine rooms or other equipment, including service corridors to these rooms.
- Service spaces.
- Janitors' rooms.
- Crawl spaces and attics or roof spaces.
- Within portions of a floor area with fixed seats in an assembly occupancy, where these portions are not designated for users of mobility aids (e.g. spaces designated for wheelchair use, seats designated for adaptable seating, or spaces for the storage of wheelchairs and mobility assistive devices).
- Suites in residential occupancy that are in storeys other than the entrance storey and that have all entrance doors at floor levels that are not required to have an accessible path of travel.
- As required by jurisdictions having authority within a suite of residential occupancy.
- Portions of a floor area that are not at the same level as the entry level, provided amenities and uses provided on any raised or sunken level are accessible on the entry level by means of an accessible path of travel.

4.3.1 General Features

- a. ensure floor surfaces are stable, firm and slip-resistant;
- b. provide signage and wayfinding cues along interior accessible routes, including entrances and exits, to provide information and guidance for all users based on the type of facility;
- c. provide headroom clearance of 2100 mm (minimum);

Durham Accessibility and Inclusivity Requirements

April 8, 2022

- d. where headroom clearance along accessible routes is less than 2100 mm, provide guards to protect users from potential hazards;
- e. design public corridors to facilitate wayfinding by using architectural treatments and elements that can be used to differentiate main corridors from secondary corridors;
- f. provide lighting in accordance with Section 5.7 Lighting requirements, as applicable;
- g. where accessible routes are more than 30 metres long, consider providing suitable rest areas; and
- h. install convex mirrors at hallway intersections along an accessible route where the line of sight is obstructed.

4.3.2 Clear Width

- a. provide clear width of 1100 mm (minimum), 1800 mm preferred (Figure 51a);
 - b. in high traffic areas, provide clear width of 1800 mm (minimum);
 - c. where clear width is less than 1800 mm along a route that exceeds 30 metres in length, provide a passing area of 1800 mm wide by 1800 mm (minimum) length at interval of no more than 30 metres (Figure 51b);
 - d. where clear width is reduced to 920 mm (minimum) for short indentation up to 600 mm (maximum), provide clear width of 1100mm (minimum) but 1800 mm preferred beyond indentation and ensure indentations or reduced clear width is not repeated in a series (Figure 51c);
 - e. where an accessible route makes a 180 degree turn around an obstacle that is less than 1200 mm wide, ensure clear width of 1100 mm (minimum) is provided, when approaching and leaving the turn, and 1200 mm (minimum) at the turn (Figure 52a)
 - f. where an obstacle is greater than 1200 mm wide, cutting the corners of the obstacle will provide additional manoeuvring space (Figure 452b); and
 - g. avoid any projections (e.g. structural columns) along clear width of circulation corridors.
- Note: 1800 mm is the preferred width.

Durham Accessibility and Inclusivity Requirements

April 8, 2022

Exception: Minimum clear width of an accessible route can be reduced as described in other sections of this document:

- at doors / doorways;
- at stairs; and
- entry to elevating devices.

4.3.3 Running and Cross-Slopes

4.3.3.1 Running Slope

- a. provide gradient of 1:20 (5%) (maximum) (Figure 453); and
- b. where gradient exceeds 1:20 (5%), ensure route is designed as a ramp.

4.3.3.2 Cross-Slope

- a. provide a gradient of 1:20 (5%) (maximum) (Figure 54).

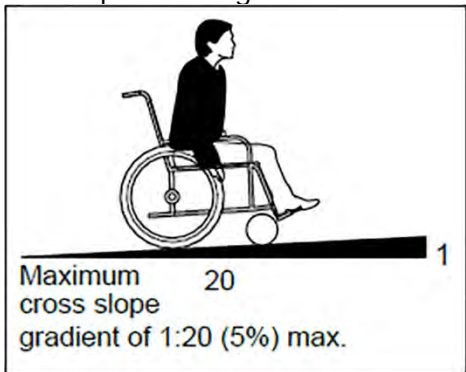

Figure 53: Running Slope

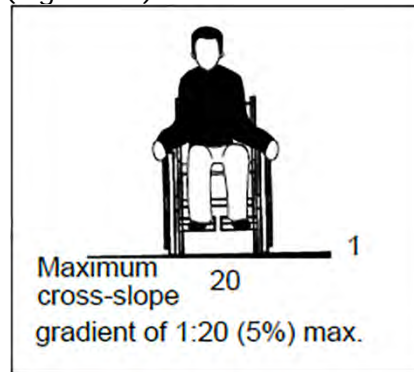

Figure 54: Cross-Slope

Durham Accessibility and Inclusivity Requirements

April 8, 2022

4.3.4 Changes in Level

Where edges of an accessible route are not level with adjacent surface:

- a. provide a high tonal contrast marking on the edge where the change in level is less than 200 mm;
- b. where the change in level is between 200 mm and 600 mm, provide a high tonal contrast curb or other barrier protection, 50 mm (minimum) high; and
- c. where the change in level is greater than 600 mm, provide guards.

Durham Accessibility and Inclusivity Requirements

April 8, 2022

4.4 Elevating Devices

Rationale

The buttons used for elevators need to address a range of functional issues, including reach, dexterity and the needs of those who are blind or have vision loss, as discussed in 5.1. Controls and Operating Mechanisms. More specific to elevators is the need to provide audible cues for those who are blind or have vision loss to identify different floor levels, as well as the direction of travel. These announcements are beneficial to anyone who uses elevators. Adequate door-closing delays provide individuals who are slower or using mobility devices additional time to reach, enter or exit the elevator car. The installation of a mirror is important to assist individuals using mobility devices to back out of an elevator where there is not sufficient space to turn around.

Platform lifts are typically only used in retrofit applications where there is not the space to accommodate an elevator shaft. Elevators that are used by all facility users are preferred to platform lifts as lifts tend to both segregate people with disabilities and limit space at entrance and stair locations. Furthermore, independent access and use of lifts is often compromised as platform lifts due to keyed controls or the limited size of lifts which may not fit larger assistive devices and/or also their support person. Whenever possible, grading or integrated elevator access needs to be incorporated. Lifts and escalators are generally not considered to be part of an accessible path of travel.

Boarding and stepping off of an escalator can be challenging for many people who may have difficulty with the timing or agility. Detectable warning surfaces provided in front of the top and bottom of escalators provide a warning to all users, especially for those who are blind or have vision loss. Contrasting colour strips on stair edges are also necessary.

Application

This section applies to elevating devices used to provide access between levels within a facility. Elevating devices include, but are not limited to:

- elevators;
- platform lifts;
- inclined lifts;
- moving walkways; and
- escalators.

All new passenger elevators, lifts, moving walkways and escalators provided in multi-storey facilities must comply with the current Ontario Building Code and other applicable requirements identified in the most up-to-date versions of:

- CAN / C.S.A. B44: Safety Code for Elevators and Escalators (Appendix E);
- CAN / C.S.A. B355: Lifts or Person with Physical Disabilities; and
- CAN / C.S.A. B651: Accessible Design for the Built Environment.

When retrofitting elevating devices at existing facilities, the Region will review options in detail, on a case-by-case basis, recognizing there may be other factors to consider, including physical or structural constraints.

Limited use / limited application (L.U. /L.A.) elevators are also not recommended for new construction due to the limited size of interior platform and other operating features. For existing facilities where L.U. / L.A. elevators are being upgraded, refer to applicable C.S.A. standards.

Detailed accessibility criteria for elevating devices are not included in these Requirements including signage requirements. The Region recommends direct referencing of other applicable and governing standards. Dedicated freight elevators are not required to comply with this section, unless the only elevators provided are used as combination passenger and freight elevators for use by the public and employees.

Durham Accessibility and Inclusivity Requirements

April 8, 2022

4.4.1 Passenger Elevators

Key design features for passenger elevators are summarized as follows: (Note: refer to C.S.A. standards for detailed criteria)

- a. ensure minimum elevator cab dimension and clear opening width of door are as identified in Table 6 below;
- b. Elevators to be provided with two-way automatic-levelling device to maintain the floor level to +/- 13mm;
- c. provide hall call buttons with visual indicators to identify when car call has been registered and answered, mounted between 890 to 1200 mm from floor, measured to centre line of button;
- d. ensure clear floor space in front of hall call buttons of 915 mm wide by 1370 mm depth (minimum);
- e. visual and audible signals at each hoistway entrance to indicate which car is answering a call and its direction of travel. Audible signals to sound once for the "up" direction and twice for the "down" direction, or alternatively, provide verbal annunciators;
- f. entrance doors with door re-opening device that senses objects or person in path of travel of closing door (e.g. automatic sensors). Provide a tactile (e.g. both raised and braille, tonal contrast surface) elevator car identification sign, with characters 50 mm high, immediately below the hoistway entrance floor designation;
- g. interior car operating controls to be mounted 1220 mm high (maximum to centre line of control preferred).
- h. interior controls to be minimum 19 mm in size and may be raised, flush or recessed, with the depth of flush or recessed buttons not exceeding 10 mm while being operated;
- i. all car control buttons to be designated with Grade 2 Braille characters and by raised standard alphabet characters for letters, Arabic characters for numbers, and standard symbols. Markings shall be a minimum of 16mm high and raised a minimum of 0.75 mm places immediately to the left of the buttons to which they apply.
- j. audible and visual car floor location indicators. Audible signal to be a verbal announcement that identifies the floor at which car has stopped;
- k. emergency two-way communication system (e.g. a hands-free speakerphone is preferred), with operating controls mounted at 1220 mm high (maximum) from floor, with accessible features (e.g. push button operation and visual indicator identifying when the system has been activated and the emergency call has been received (e.g. to identify "help is on the way" for users with hearing loss); and
- l. 800 – 920 mm high handrails on all non-access walls, with high colour contrast.

Durham Accessibility and Inclusivity Requirements

April 8, 2022

Table 6: Minimum Dimensions for Elevator Car and Door Clear Width. All dimensions are in millimeters (mm).

| Door Location | Door Clear Width | Inside Car Side to Side | Inside Car Back Wall to Front Return | Inside Car Back Wall to Inside Face of Door |
|------------------------------------------------------------------------------|------------------|-------------------------|--------------------------------------|---------------------------------------------|
| Centred | 1065 | 2030 | 1295 | 1370 |
| Off-Centre | 915* | 1725 | 1295 | 1370 |
| Any | 915* | 1370 | 2030 | 2030 |
| Any | 915* | 1525 | 1525 | 1525 |
| Minimum Dimension of L.U./L.A. (limited use / limited application) elevators | | | | |
| Any | 815 | 1370 | 1370 | Not Specified |

*Note: A tolerance of minus 16 mm shall be permitted.

Source: Information in this Table was adapted from Appendix E of CSA-B44-16, "Elevator Requirements for Persons with Physical Disabilities in Jurisdictions enforcing NBCC". As identified in this document, information is based on Table 407.2.8 in ICC /ANSI A117.1 (metric values only).

Durham Accessibility and Inclusivity Requirements

April 8, 2022

4.5 Washrooms

Rationale

As an integral feature of a facility, washroom facilities are to accommodate the range of staff and public that will use the space. Although many people with disabilities use toilet facilities independently, some may require assistance. Where the individual providing assistance is of the opposite gender then typical stalled gender-specific washrooms are unusable and an individual accessible washroom is preferred. Parents and caregivers with small children and strollers may also benefit from a large, individual washroom with toilet and change facilities contained within the same space. The provision of all-gender washroom facilities will create a more inclusive environment for all users. Individual accessible washrooms are to be large enough to accommodate electrically assisted adult change benches and other attendant care amenities (e.g. shelving).

Circumstances such as wet surfaces and the act of transferring between toilet and wheelchair or scooter can make toilet facilities accident-prone areas. An individual falling in a washroom with a door that swings inward may block his or her own rescuers from opening the door. Due to the risk of accidents or health issues, design decisions such as door swing direction and material finishes have safety implications and make toilet facilities a critical location for emergency call switches. The appropriate design of all features will increase the usability and safety of toilet facilities.

The identification signage for washrooms involves designs that considered a wide range of user needs. For children or someone who cannot read text, a symbol or pictogram is important. Those who are blind or have vision loss also benefit from braille and other features. High colour and tonal contrasting door frames, door hardware and accessories all contribute to accessibility.

Application

This section applies to washroom facilities and elements within a site and facility including, but not limited to:

- Multiple occupancy washrooms;
- universal washrooms; and
- change rooms with washroom features.

Refer to Table 7 and Table 8 in sub-section 4.5.1 Provision and Locations or minimum number of Universal Washrooms and Accessible Water Closet Stalls to be provided in a building in which washrooms are required as per subsection 3.7.4 of the Ontario Building Code.

If retrofitting multiple occupancy washrooms with accessible water closet stalls is not possible, identifying additional space or providing a universal washroom is recommended.

4.5.1 Provision and Locations

- a. minimum requirement for universal washrooms is to be in accordance to Table 7, but it is preferred to provide at least one universal washroom on every occupied floor of a facility;
- b. provide minimum number of accessible water closet stalls or enclosures per washroom in accordance to Table 8;
- c. locate centrally within a facility along an accessible route, within 45 metres (maximum) of general washrooms;
- d. where washrooms are not accessible, provide directional signage to indicate location of nearest accessible washroom on the same floor
- e. where one water closet is required for males and one water closet is required for females, the following may be provided:
 - i. one universal washroom; and
 - ii. one washroom containing one water closet to be used by both sexes provided the door to the room can be locked from the inside;
- f. in a storey that is not required to have an accessible path of travel, ensure at least one ambulatory water closet is provided.

Durham Accessibility and Inclusivity Requirements

April 8, 2022

Table 7: Minimum Number of Universal Washrooms per Building

| Number of Storeys in Building | Minimum Number of Universal Washrooms per Building |
|-------------------------------|-----------------------------------------------------------------------------|
| 1-3 | 1 |
| 4-6 | 2 |
| Over 6 | 3, plus 1 for each additional increment of 3 storeys in excess of 6 storeys |

Table 8: Minimum Number of Water Closet Stalls Required to be Accessible

| Number of Water Closets per Washroom | Minimum Number of Accessible Water Closet Stalls or Enclosures per Washroom |
|--------------------------------------|-------------------------------------------------------------------------------------------------------------------------------------------------------|
| 1-3 | 0, if universal washroom is provided on same floor within 45 m of washroom or 1, if universal washroom is not provided on the same floor within 45 m. |
| 4-9 | 1 |
| 10-16 | 2 |
| 17-20 | 3 |
| 21-30 | 4 |
| Over 30 | 5, plus 1 for each additional increment of 10 water closets per washroom in excess of 30 water closets per washroom. |

4.5.2 Multiple Occupancy Washrooms

For multiple occupancy washrooms with accessible water closet stalls:

- a. identify clearly with signage, indicating male or female where applicable, with other accessibility features (e.g. braille, tactile, International Symbol of Accessibility);
- b. where doors are provided at washroom entrance, provide a clear width of 950 mm (minimum), when the door is in the open position and equip with power door operators;
- c. where possible, consider the use of privacy walls or specialized configuration of entrance vestibules to avoid the need for doors and power door operators;
- d. ensure lighting level is evenly distributed in accordance with Section 5. Lighting requirements, as applicable;
- e. ensure minimum clearance of 1700 mm between the inside face of an in-swinging entrance door and the outside face of an adjacent water closet stall;
- f. ensure minimum clearance of 1400 mm between outside wall of stall and any wall-mounted fixtures or other obstructions (Figure 55);
- g. provide a clear floor space of 1500 mm by 1500 mm (minimum) in front of the accessible water closet stall or enclosure;
- h. ensure a clear turning diameter of 1500 mm (minimum) is provided inside washroom circulation area (1700 mm diameter preferred where space permits), 500 mm (maximum) of which may be under the lavatory to allow users of mobility aids to make a 180° turn (Figure 55);
- i. ensure floor surfaces are slip-resistant, with a maximum slope of 1:50
- j. (2%);
- k. provide accessible lavatories with washroom amenities, as identified in the section;
- l. provide accessible water closet stalls with suitable clear floor space, as identified in this section;
- m. install audible and visual fire alarm system; and
- n. install any drains out of the path of travel.

Durham Accessibility and Inclusivity Requirements

April 8, 2022

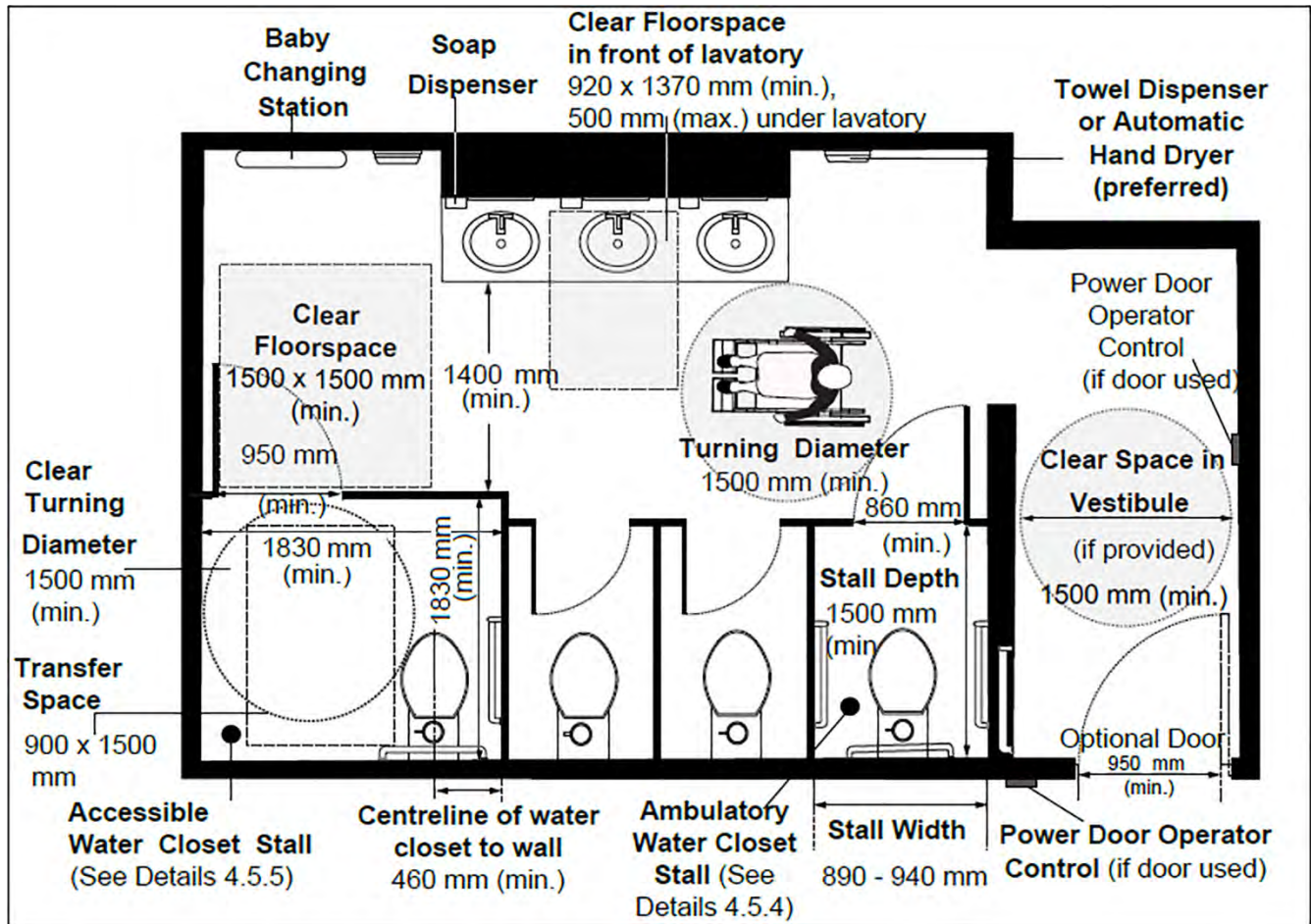

Figure 55: Example of Multiple Occupancy Washroom Layout

4.5.3 Universal Washrooms

Where universal washrooms are provided:

- a. locate in the same vicinity as other washrooms (e.g. Men's & Women's multiple occupancy washrooms) along the shortest accessible route;
- b. identify clearly with signage, including braille, tactile letters, gender inclusive pictograms and the International Symbol of Accessibility;
- c. provide accessible entrance door:
 - i. with clear width of 950 mm (minimum), when the door is in an open position; operate using closed fist and force not more than 22.2 N.
 - ii. equip with power door operator;
 - iii. provide locking mechanism that can be locked from the inside and released from the outside, in case of emergency;
 - iv. mount graspable operating and locking mechanisms 900 to 1000 mm above floor;
 - v. if it is an outward swinging door, provide door pull 140 mm long (minimum), located on the inside so that its midpoint is between 200 mm and 300 mm from the latch side of the door; and not more than 1100 mm above the finished floor;
- d. ensure internal dimension between walls is no less than 1700 mm (2500 mm preferred);
- e. ensure a clear turning diameter of 1700 mm (minimum) is provided inside the universal washroom (Figure 52);
- f. ensure floor surface is firm, stable and slip-resistant;

Durham Accessibility and Inclusivity Requirements

April 8, 2022

- g. provide one accessible lavatory with other washroom amenities including but not limited to mirror, soap dispenser, paper towel dispenser, automatic hand dryer (preferred), coat hook, and toilet paper dispenser as identified in this section;
- h. where space is available, provide both a hand dryer and a paper towel dispenser;
- i. provide one accessible water closet with suitable rear and side grab bars (e.g. horizontal, L-shaped and fold-down grab bars) as identified in this section;
- j. provide a fold-down grab bar mounted on the transfer side of the water closet for additional support;
- k. provide motion sensor or automatic illumination of interior;
- l. provide lighting in accordance with Section 5.7 Lighting requirements, as applicable;
- m. install audible and visual fire alarm systems;
- n. provide a clear floor space 810 mm wide by 1830 mm long in each universal washroom for an adult-size change table (Figure 56);
- o. where the clear floor space provided for an adult-size change table is adjacent to a wall, ensure reinforcement is installed in the wall to permit the future installation of the change table;
- p. where an adult-size change table is installed, ensure a clear floor space of 760 mm wide by 1500 mm long, parallel to the long side of the adult-size change table;
- q. where installed, ensure baby changing stations and / or adult size change tables adhere to the requirements identified in sub-section 4.5.9.2;
- r. provide shelf as identified in sub-section 4.5.8.1;
- s. ensure drains are installed out of the path of travel; and
- t. provide an emergency call system with the following features:
 - i. consists of visual and audible signal devices both inside and outside of the washroom that are activated by a push control device inside the washroom;
 - ii. includes an emergency sign that contains the words "In the event of an emergency, push emergency button and audible and visual signal will activate." in letters at least 25 mm high with a 5 mm stroke and that is posted above the emergency button; and
 - iii. where facilities have the capacity and where staff is available, ensure the call system is linked to a display panel at a reception / information counter or to a centrally monitored station (e.g. security desk).
 - iv. a cancellation feature to turn off the alarm when it is accidentally activated is preferred.

Durham Accessibility and Inclusivity Requirements

April 8, 2022

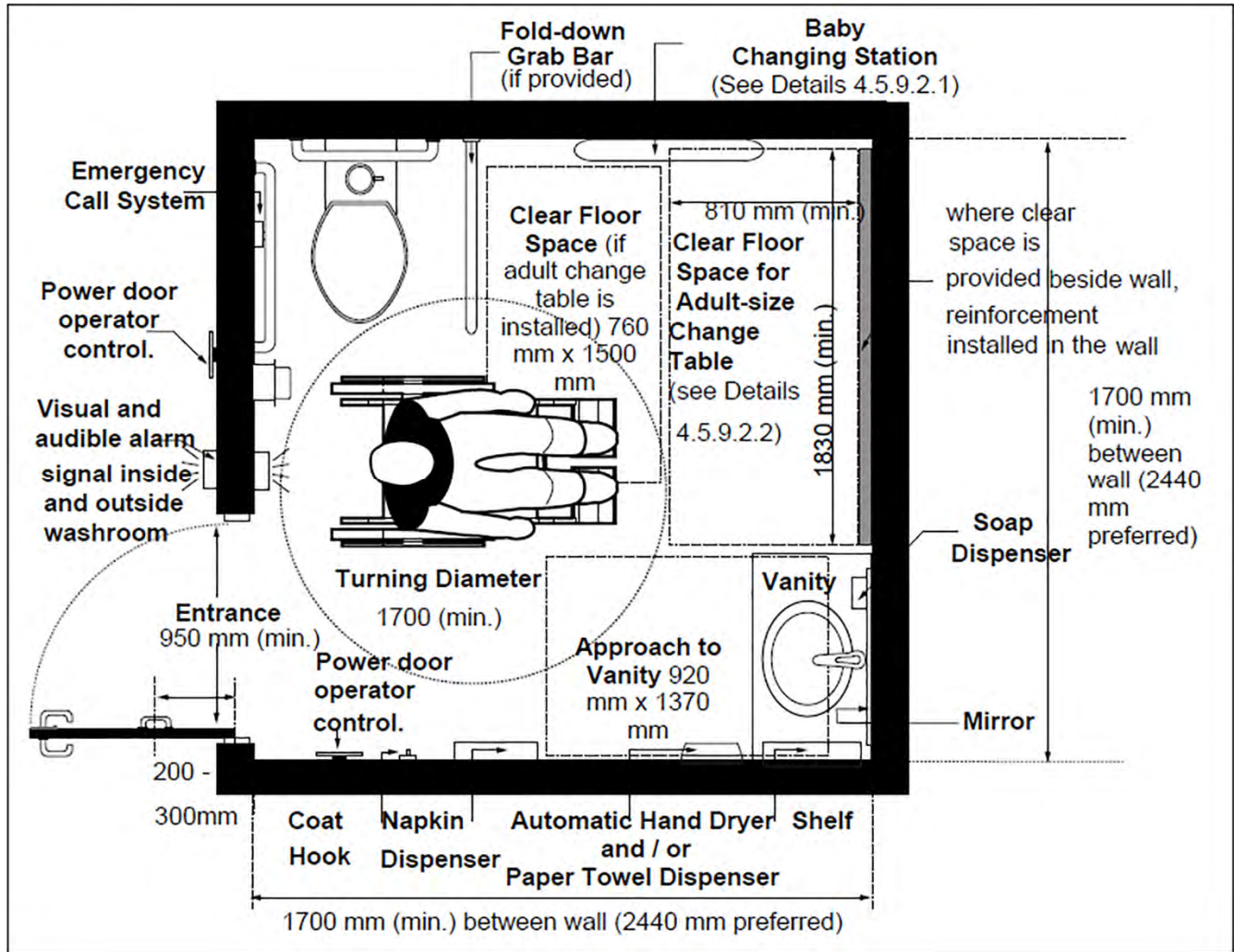

Figure 56: Universal Washroom

4.5.4 All Gender Washrooms

The inclusion of all-gender washrooms provides a more inclusive environment for users of a facility and should be included whenever possible.

Where individual all-gender washrooms are appropriate, they should be designed as a typical individual accessible washroom but may not require the adult change bench. These washrooms shall include appropriate accessible all-gender signage (See Section 5.8 Signage and Wayfinding).

Where all-gender stalled washrooms are appropriate, these washrooms shall:

- a. be designed as a women's stalled washroom;
- b. Provide stall partitions and doors that are full height with no gaps on the sides of the stall doors for increased privacy;
- c. Provide shared sinks with appropriate number of fully accessible sinks; and
- d. include appropriate accessible all-gender signage (See Section 5.8 Signage and Wayfinding).

Refer also to Section 4.5.2 (Multiple Occupancy Washrooms).

Durham Accessibility and Inclusivity Requirements

April 8, 2022

4.5.5 Ambulatory Water Closet Stalls

Where ambulatory water closet stalls are provided for users with limited mobility who do not use wheeled mobility aids (e.g. canes or crutches):

- a. identify clearly with signage that includes a pictogram or symbol of a person with a cane;
- b. ensure stall depth is 1500 mm (minimum), with 890 to 940 mm width;
- c. provide a stall door:
 - i. with clear width of 950 mm (minimum);
 - ii. that swing outward, unless the minimum dimensions of the stall identified above are not located within the door swing;
 - iii. with spring-type or gravity hinges so that the door closes automatically;
 - iv. capable of being latched from the inside and released from the outside in case of an emergency;
 - v. with a door pull on both sides of the door, near the latch side of the door, located at a height not less than 900 mm and not more than 1100 mm above the finished floor;
- d. equip with water closet located so that its centre line is centred between the partition walls (Figure 55);
- e. install L-shaped grab bars, as identified in this section, on each side of a water closet;
- f. provide a sign on the door that indicates that the stall is suitable for users who may require grab bar assistance;
- g. install a coat hook as identified in this section.

4.5.6 Accessible Water Closet Stalls

Where accessible water closet stalls are provided in multiple occupancy washrooms:

- a. mark accessible water closet stall with International Symbol of Accessibility;
- b. provide a clear turning space of 1500 mm diameter (minimum) (Figure 57); and
- c. provide minimum 1830 x 1830 internal dimensions.
- d. where space is available, provide a larger accessible stall that includes a lavatory inside with required amenities and floor space clearances.

4.5.6.1 Stall Doors

- a. when door is in an open position, provide clear width of 950 mm (minimum);
- b. ensure the door is aligned with water closet transfer space (e.g. door is positioned on opposite side of water closet) (Figure 58);
- c. ensure door swings outward, unless a clear floor area of 820 mm wide by 1440 mm long (minimum) is provided within the stall or enclosure to permit the door to be closed inside without interfering with the mobility device;
- d. ensure door is self-closing with spring-type or gravity hinges, so that when at rest, the door will be ajar not more than 50 mm beyond the jamb;
- e. provide accessible locking mechanisms, with stall capable of being locked from the inside by a control that is operable with a closed fist;
- f. ensure door can be released from the outside in case of emergency; and
- g. provide horizontal D-type door pull on inside and outside of the door (Figures 57 & 58):
 - i. ensure hardware provides high tonal contrast with mounting surface;
 - ii. provide length of 140 mm (minimum);
 - iii. mounted close to the latch side 200 mm maximum from the door edge (reference OBC appendix).
 - iv. mounted at a height between 800 mm to 1080mm above the finished floor.

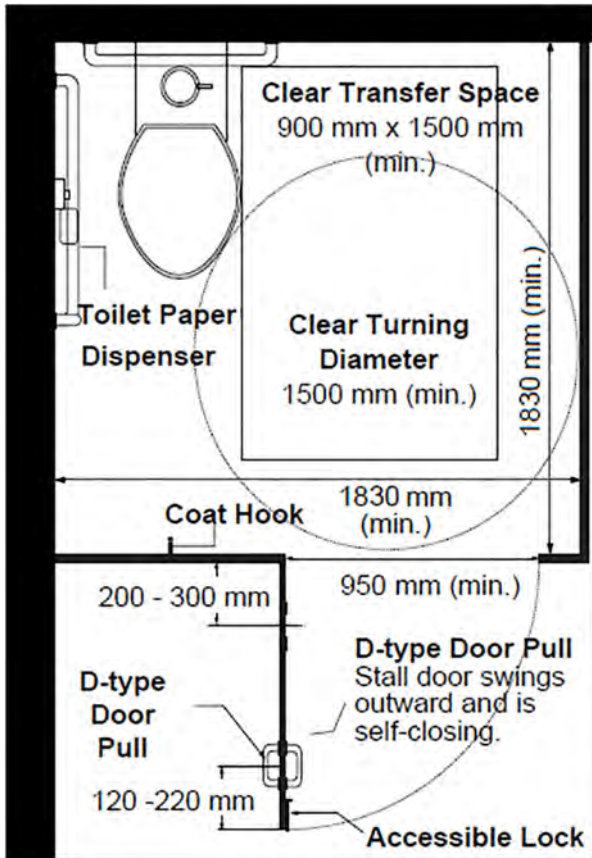

Figure 57: Water Closet Stall - Space Requirements

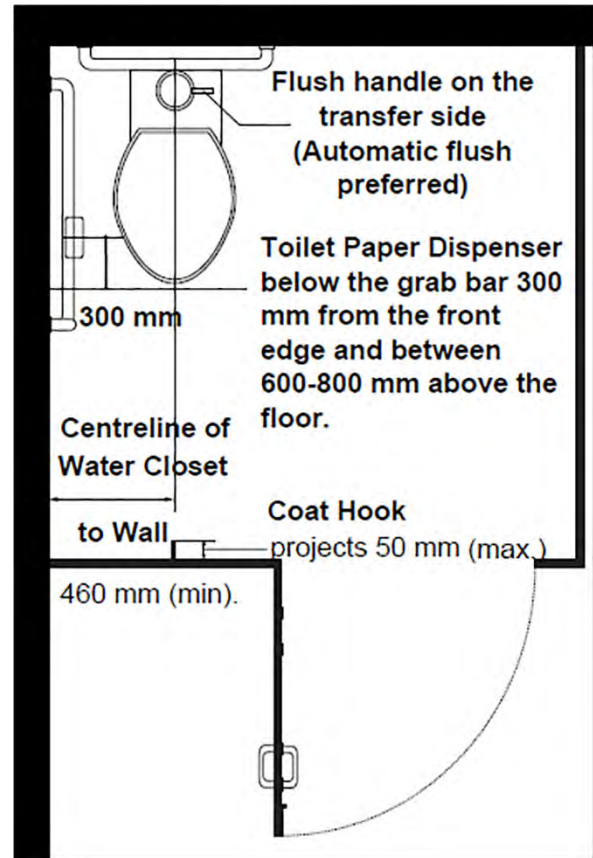

Figure 58: Water Closet Stall Features

4.5.7 Water Closets

- a. mount seat between 430 mm and 485 mm high from floor (Figure 59);
- b. install water closet so that:
 - i. the centreline of water closet from any adjacent side wall is between 460 mm and 480 mm and an unobstructed transfer space of 900 mm wide by 1500 mm deep (minimum) is provided on the other side of the water closet (Figure 57); or
 - ii. a clear transfer space of at least 900 mm wide and 1500 mm deep is provided;
- c. provide a back support where there is no seat cover / lid or tank, and where there is a tank, ensure tank lid is securely attached;
- d. ensure seat is not spring activated;
- e. wall hung water closets are preferred because they provide additional space at toe level;
- f. provide internal extension guards that will not allow the seat to slide;
- g. mount toilet paper dispenser on the sidewall closest edge to the water closet below the grab bar, 600 to 800 mm high from floor with the closest edge of the dispenser 300 mm from the front edge of the water closet;
- h. where large toilet paper dispensers are used, ensure they are suitably mounted and do not obstruct the use of the adjacent grab bar (space of 100 mm is recommended between grab bar and toilet paper dispenser);
- i. install automatic, lever-type or other flush control operable with a closed fist (e.g. push button control) on transfer side and is located between 500-900 mm above the floor; and
- j. install at least one coat hook mounted at 1200 mm (maximum) high from floor, on a side wall and projecting 50 mm (maximum) from mounting surface.

Durham Accessibility and Inclusivity Requirements

April 8, 2022

4.5.8 Grab Bars

Where grab bars are provided:

- a. ensure surface is non-abrasive and slip-resistant (e.g. peened finish)
- b. ensure a high tonal contrast between grab bar and mounting surfaces;
- c. provide grasping surface that is circular in shape, with diameter not less than 30 mm and not more than 40 mm;
- d. ensure clear space of 38 mm (minimum) and 50 mm (maximum) between mounting surface and the inside surface of the grab bar;
- e. mount securely to withstand a force of 1.3 Kilonewtons applied in all directions; and
- f. ensure grab bar does not rotate within its fittings.

4.5.8.1 Horizontal Grab Bars

- a. ensure length of 600 mm (minimum);
- b. mount between 840 and 920 mm high from floor level, centered behind water closet; and
- c. where water closet has a water tank, mount grab bar 150 mm above the tank (Figure 59).

4.5.8.2 L-shaped Grab Bars

- a. ensure length of 750 mm (minimum) for both vertical and horizontal components (Figure 60);
- b. mount vertical component 150 mm (maximum) from front of water closet; and
- c. mount horizontal component 750 mm high above floor.

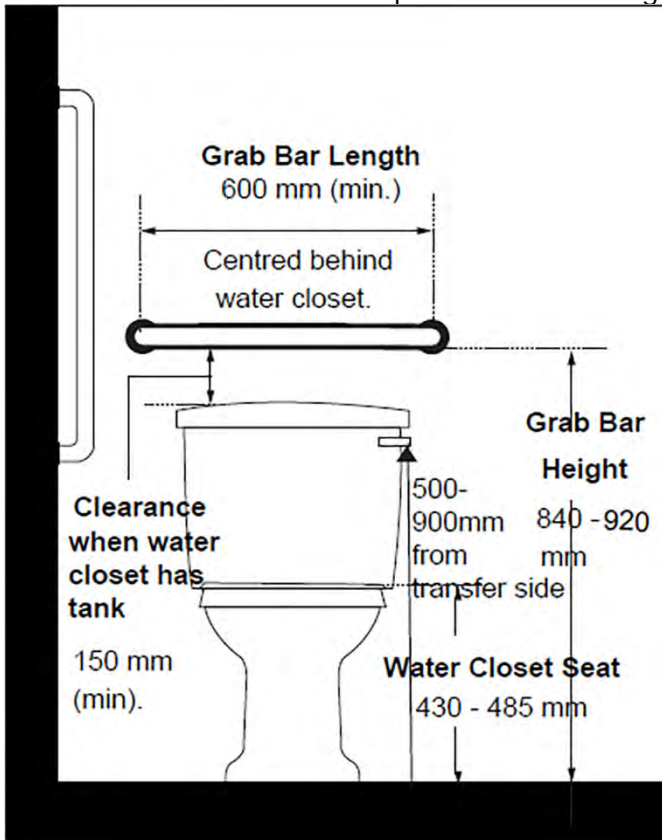

Figure 59: Horizontal Grab Bar (Water Closet with Water Tank)

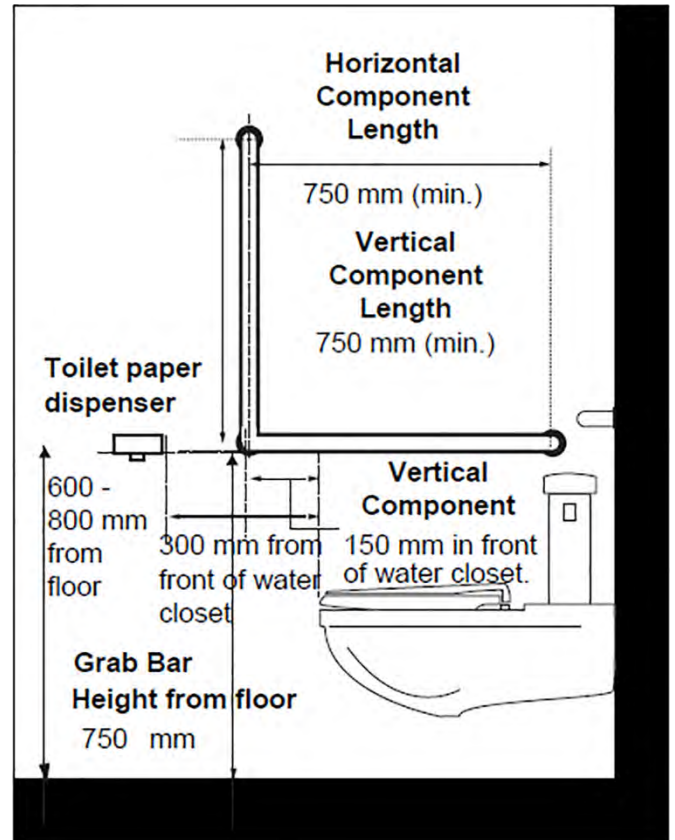

Figure 60: L-shaped Grab Bar (Wall Hung Water Closet with Flush Valve)

4.5.8.3 Fold-Down Grab Bars

Where fold-down grab bars are provided:

- a. mount on the wall behind the water closet;
- b. locate on transfer space side;

Durham Accessibility and Inclusivity Requirements

April 8, 2022

- c. ensure length of 750 mm (minimum);
- d. mount between 390 mm and 410 mm from centreline of water closet not less than 30 mm and not more than 40 mm in diameter. (Figure 61a);
- e. mount with the horizontal component at 750 mm high from floor level (Figure 61b);
- f. ensure force required to pull down grab bar is no more than 22 Newtons; and
- g. where transfer space is provided on both sides of the water closet, provide a fold-down grab bar on each side.

4.5.9 Lavatories

Provision of at least one accessible lavatory is required in each accessible washroom facility:

- a. ensure centreline of lavatory is 460 mm (minimum) from adjacent side wall;
- b. ensure top surface is continuous and provides a high tonal contrast with adjacent wall surfaces;
- c. rim height not more than 865 mm above finished floor (Figure 62a);
- d. provide clearances underneath lavatory no less than (Figure 62a):
 - a. 920 mm wide;
 - b. 735 mm high at front edge;
 - c. 685 mm high at 205 mm back from front edge; and
 - d. 350 mm toe space height from a point 300 mm back from edge to the wall;
- e. provide automatic control or lever-type faucet (minimum 75 mm long) or operable with closed fist located more than 485 mm depth from edge of basin (Figure 58a);
- f. mount soap dispenser not more than 1100 mm above the finished floor and within 500 mm front of the lavatory;
- g. minimum clear floor space of 920 mm wide by 1370 mm deep (minimum), of which within 500 mm is allowed under the lavatory (Figure 62b);
- h. ensure water temperature is controlled to a maximum of 43°C; and
- i. ensure water pipes are covered or insulated if they abut the clearances noted above, or use offset trap and drain pipes so they do not enter into the knee space below the lavatory.

4.5.9.1 Shelves

- a. mount 1100 mm (maximum) high above floor;
- b. ensure shelves do not project more than 100 mm from mounting surface along an accessible path of travel (Figure 62b); and
- c. where provided at lavatory, mount 200 mm (maximum) above top surface of lavatory.

Durham Accessibility and Inclusivity Requirements

April 8, 2022

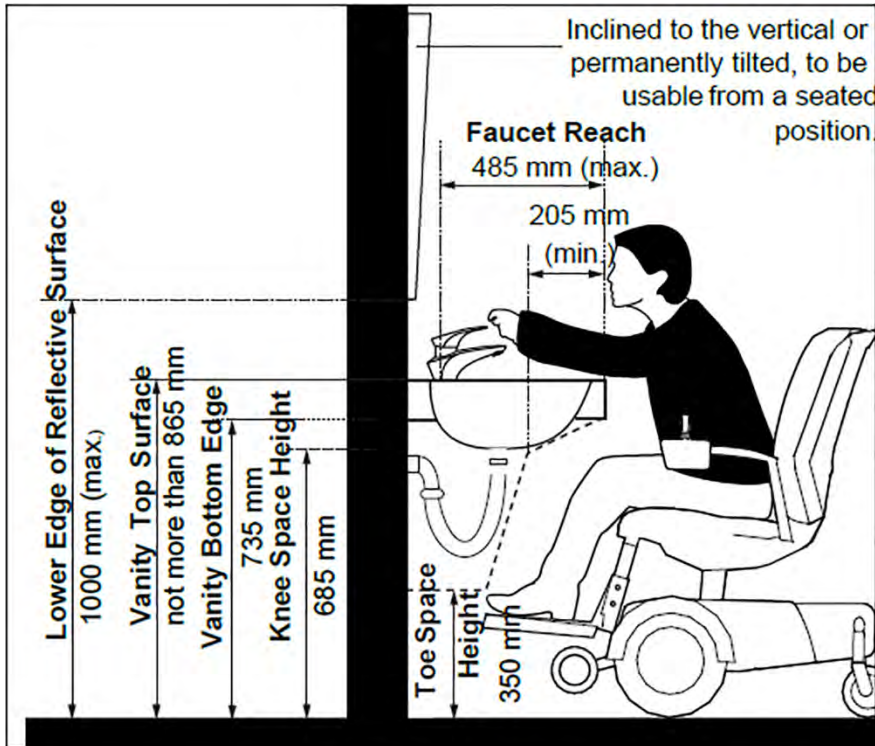

Figure 62a: Lavatories - Section View

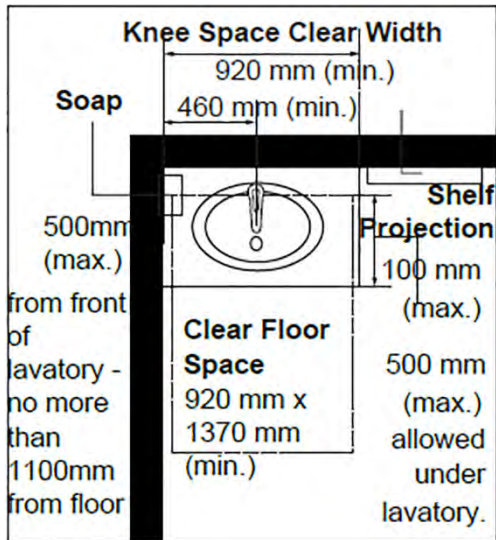

Figure 62b: Lavatories - Plan View

4.5.10 Washroom Amenities

Washroom amenities include, but are not limited to, hand dryers, paper towel dispensers, soap dispensers, hand sanitizer dispensers, waste bins, mirrors, changing stations and tables. Where provided:

- ensure wall mounted amenities do not project more than 100 mm from wall along an accessible path of travel;
- provide high tonal contrast between amenities and mounting surfaces;
- ensure any operating controls are mounted between 900 mm and 1200 mm high above floor, operable with a closed fist (Figure 63);

Durham Accessibility and Inclusivity Requirements

April 8, 2022

- d. ensure the soap dispenser is installed not more than 1100 mm from the floor and within 500 mm from the front of the lavatory.
- e. where amenities are mounted at lavatories (e.g. hand dryers, paper towel dispensers), install between 900 mm - 1200 mm (max) above the floor and 610 mm (maximum) measured horizontally from the edge of the lavatory;
- f. provide minimum clear floor space of:
 - i. 920 mm wide by 1370 mm deep to allow front approach; and
 - ii. 1525 mm wide by 915 mm deep to allow side approach.
- g. where possible, provide automatic controls as they are easy to use by a wider range of users and have improved hygienic performance.

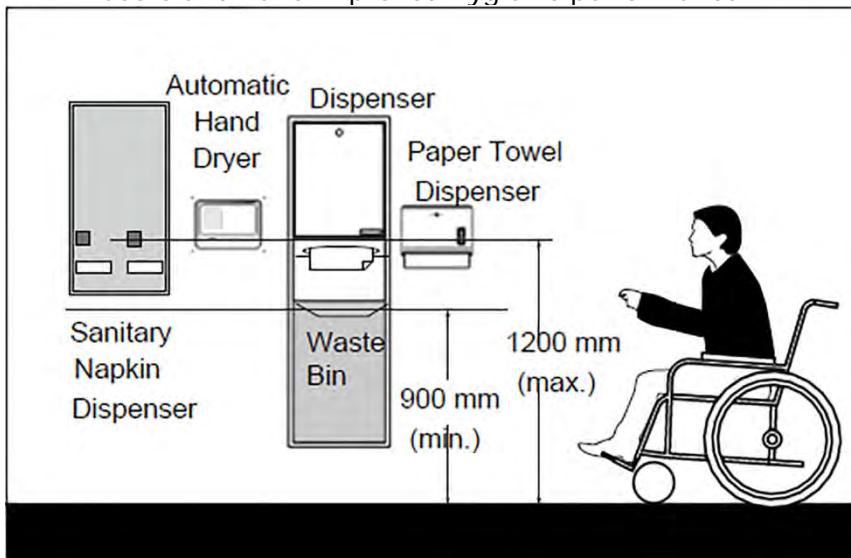

Figure 63: Typical Washroom Amenities

4.5.10.1 Mirrors

- a. mount with the bottom edge of the reflecting surface at 1000 mm (maximum) high above floor (Figure 58a) or inclined to the vertical to be usable from a seated position;
- b. ensure the top edge of mirrors is 1880 mm (minimum) high above floor to be usable by people who are ambulatory and those who use wheeled mobility devices;
- c. ensure lighting level over mirrors does not create reflected glare; and
- d. where full length mirrors are provided, ensure they are not installed where they will reflect path of travel and cause confusion for users.
- e. where tilted mirrors are provided, ensure they are permanently tilted for use at all times from a seated position by children or users of shorter stature.

4.5.10.2 Baby Changing Stations

- a. where provided, ensure at least one is accessible for users with disabilities with unit placed in a location that does not obstruct adjacent paths of travel when in use and positioned in close proximity to a lavatory and waste receptacle;
- b. ensure suitable clear floor space of:
 - i. 920 mm wide by 1370 mm depth is provided for a forward approach;
 - ii. 1525 mm wide by 915 mm depth for a side approach (whether standing or seated) in front of unit;
- c. ensure the required floor clearance for changing station does not overlap with floor clearances of other fixtures, when the changing station is folded up;
- d. mount with the highest edge or component of the station between 730 and 865 mm;
- e. ensure knee clearance of 685 mm high and 480 mm depth is provided;
- f. where a folding changing station is provided, ensure projection from wall of 100 mm (maximum) when in folded position and located along accessible path of travel; and

Durham Accessibility and Inclusivity Requirements

April 8, 2022

- g. where a folding-type is provided, ensure operating control:
 - i. is mounted no more than 1200 mm (Figure 64a);
 - ii. operable with a closed fist and without tight grasping, pinching of fingers or twisting of wrist.
- h. ensure changing stations are not located in accessible water closet stalls, especially in high use washrooms.

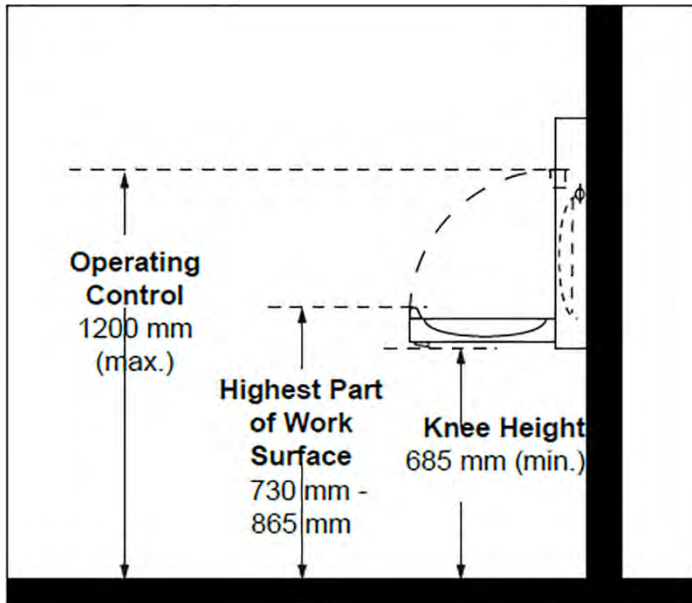

Figure 64a: Folding Baby Changing Station - Section View

4.5.10.3 Adult-Size Change Tables

Adult-size change tables located in universal washrooms are of benefit to many individuals, and may be used as changing stations or tables. They allow people with balance or strength problems to sit and allow people with disabilities to lie down and be changed with the assistance of an attendant as might be required.

Adult-size change tables are also useful in change rooms where people are expected to change clothing.

Where an adult-size change table is installed in a universal washroom:

- a. provide a clear floor space of 760 mm wide by 1500 mm long (minimum), parallel to the long side of the table; and
- b. when fully loaded, ensure the surface height above the floor is adjustable from between 450 mm and 500 mm at the low range to between 850 mm and 900 mm at the high range (Figure 64b);
- c. where a fold-down change table is provided:
 - i. install so that it does not encroach into the clear transfer space adjacent to the water closet;
 - ii. ensure operating mechanisms (e.g. latches, handles and pulls) are 1200 mm high (maximum); and
 - iii. ensure operating mechanisms are operable with a closed fist and without tight grasping, pinching of fingers or twisting of wrist;
- d. ensure changing tables can support a minimum load of 1.33 Kilonewtons;
- e. provide a high tonal contrast between change table surface and adjacent mounting surface; and
- f. ensure change table surfaces are free of sharp edges or abrasive materials, and are easy to clean.

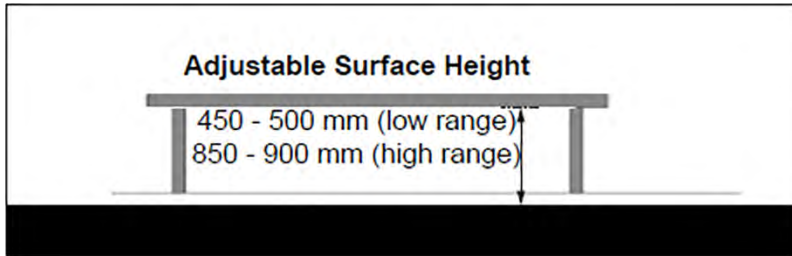

Figure 64b: Adult-Size Change Table

4.5.11 Urinals

- a. Where more than one urinal is provided in men's multiple occupancy washrooms, provide at least one accessible urinal:
- b. locate within accessible path of travel with no step in front of the urinal;
- c. mount urinal on wall with the lower rim located 430 mm (maximum) above floor , OR provide a floor mounted urinal with the rim level with the floor level (Figure 65a);
- d. ensure the upper rim is no lower than 860 mm high above floor;
- e. ensure depth of 345 mm (minimum), measured from the outer face of the urinal rim to the back of the fixture (Figure 65a);
- f. ensure urinal has high tonal contrast compared with back wall;
- g. provide lever, automatic, or other flush control operable with a closed fist, with force not more than 22.N (e.g. push button control) mounted 900-1100 mm above the finished floor. (Figure 65a);
- h. provide clear floor space of 915 mm wide by 1370 mm deep (minimum) centered in front of urinal for front approach;
- i. provide grab bars, on each side of urinal (Figure 65b):
 - i. mount vertically, with centre line at 1000 mm high above floor;
 - ii. mount not more than 380 mm from centre line of urinal;
 - iii. with length of 600 mm (minimum); and
 - iv. with high tonal contrast compared to back wall;
- j. install centre line indicator for all urinals to facilitate use by people with vision loss (Figure 65b):
 - i. centred above the urinal 50 mm wide (maximum);
 - ii. extending 1300 mm (minimum) above floor but never less than 150 mm above the upper urinal rim;
 - iii. ensure indicator has high tonal contrast compared with back wall and raised 3 mm (minimum); and
 - iv. where more than one urinal is provided in a washroom, provide a centreline indicator at each urinal;
 - v. various elements may be used, such as exposed pipping, architectural features (e.g. raised ceramic tiles) etc.;
- k. where privacy screens are provided (Figure 65b):
 - i. provide clearance of 920 mm (minimum) between screens;
 - ii. ensure a clearance of 50 mm (minimum) from the grab bars;
 - iii. ensure colour contrast between screens and surrounding surfaces; and
 - iv. ensure the vertical outer edge provides a high tonal contrast.

Durham Accessibility and Inclusivity Requirements

April 8, 2022

4.6 Showers

Rationale

Roll-in curbless shower stalls eliminate the tripping hazard and barrier of stepping over a threshold and are essential for people with disabilities who use wheelchairs or other mobility devices in the shower. Grab bars and non-slip materials are safety measures which will support all users individual. Additional equipment such as a hand-held shower head or a folding transfer bench, may be an asset to a variety of disabilities but also convenient for others. Equipment controls with high colour and tonal contrasts from the shower surroundings will also assist people who are blind or have vision loss.

Application

This section applies to staff and public showers provided in all facilities.

4.6.1 Provision

- a. provide at least one accessible shower stall where a group of showers are provided in a facility, as identified in Table 9 below;
- b. where additional space is available, provide an accessible drying area, adjacent to the shower area with bench and grab bars (Figure 67).

Table 9: Minimum Number of Accessible Showers

| Number of Showers provided in a Group | Minimum number of Accessible Showers required |
|----------------------------------------------|-----------------------------------------------------------------|
| 1-7 | 1 |
| Over 7 | 1, plus 1 for each additional increment of 7 showers in a group |

4.6.2 Design and Layout

- a. ensure floor space of 1525 mm wide by 920 mm deep (minimum);
- b. provide additional clear floor space of 1525 mm wide by 920 mm deep (minimum) at shower entrance (Figure 66);
- c. provide covered trench drain that is suitably located, based on the overall design of the stall and drainage requirements (e.g. preference is for water to drain away from user as much as possible);
- d. ensure level entry or beveled threshold, 13 mm high (maximum);
- e. ensure floor surface is slip-resistant;
- f. where enclosure screens or curtains are provided, ensure mounting provisions do not obstruct transfer from mobility aids to shower seat; and
- g. provide lighting in accordance with Section 5.7 Lighting requirements, as applicable.

Durham Accessibility and Inclusivity Requirements

April 8, 2022

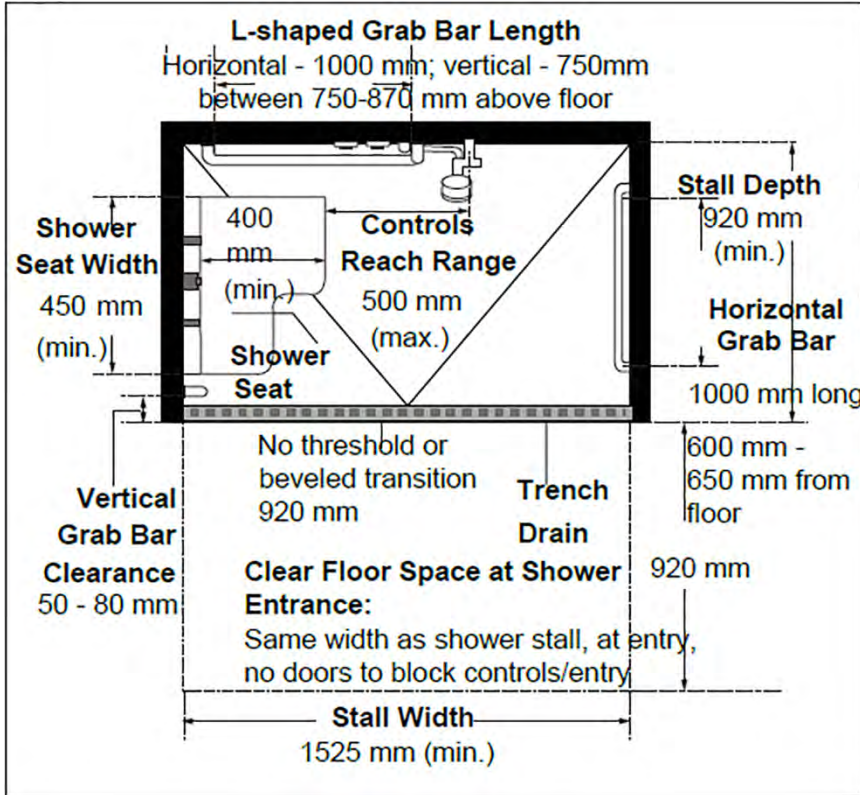

Figure 66: Shower Design and Layout - Plan View

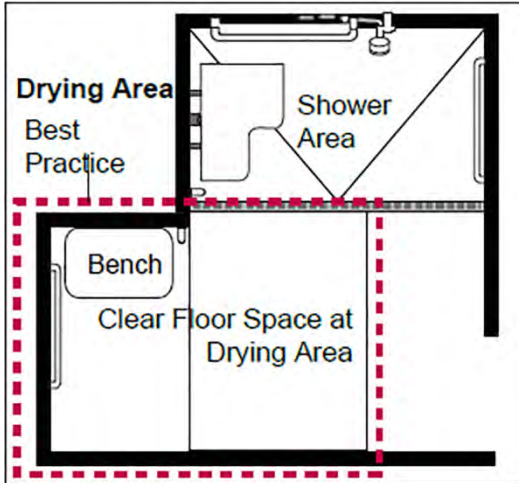

Figure 67: Drying Area - Plan View

4.6.3 Controls and Accessories

4.6.3.1 General

- provide lever type or automatic controls that can be operated with a closed fist, with a force not more than 22.2 N and mounted on a wall opposite the entrance no more than 1200 mm above the finished floor.
- ensure all shower controls, including shower head, are located no more than 500 mm from the edge of the seat (Figure 66);
- provide a pressure equalizing or thermostatic mixing valve to control water pressure, mounted no more than 1200 mm above floor and is located within reach of the seat; and

Durham Accessibility and Inclusivity Requirements

April 8, 2022

- d. provide fully recessed soap holders reachable from a seated position.

4.6.3.2 Shower Head

- a. provide hand-held shower head with flexible hose 1800 mm (minimum) length;
- b. provide vertical support to mount shower head to allow operation as a fixed shower head;
- c. can be used in a fixed position at a height of 1200 mm and 2030 mm from the finished floor; and
- d. ensure the vertical support placement does not obstruct the use of grab bars. (Figure 68).

4.6.3.3 Shower Seat

- a. provide a fixed shower seat or a hinged seat that is not spring-loaded;
- b. ensure the shower seat has a smooth, water-resistant and slip-resistant surface with no rough edges;
- c. mount shower seat on the same side as the vertical grab bar;
- d. mount between 460 mm and 480 mm high above finished floor, with the front edge of the seat located within 500 mm of shower head and controls (Figure 68);
- e. provide surface 450 mm wide by 400 mm deep (minimum) with rear edge 65 mm from wall (Figure 66); and
- f. mount securely, capable of holding a minimum load of 1.3 kN.

4.6.4 Grab Bars - 2 types

- a. ensure grasping surface is non-abrasive, slip-resistant and provide a high tonal contrast compared with mounting surface;
- b. provide circular profile, with diameter between 35 mm and 40 mm;
- c. ensure clear space of 50 mm (minimum) between mounting surface and grab bar, as well as between ends of grab bars and any adjacent wall; and do not obstruct shower controls;
- d. mount securely to withstand a force of 1.3 kN applied in all directions.

4.6.4.1 Vertical Grab Bar

- a. mount on the side wall;
- b. ensure length of 1000 mm;
- c. mount with bottom edge between 600 mm and 650 mm high above floor to provide additional support when entering / exiting or when transferring to the seat; and
- d. provide a clearance between 50 mm and 80 mm from the adjacent clear floor space (Figure 66).

4.6.4.2 L-Shaped Grab Bar

- a. mount on wall opposite to shower entrance between the shower head and shower controls;
- b. ensure length of horizontal component is 1000 mm long and vertical component is 750 mm long (Figure 66); and
- c. mount with horizontal component at 750-870 mm high above floor and vertical component mounted between 400-500 mm from the side wall on which the vertical grab bar (4.6.4.1) is mounted.

Durham Accessibility and Inclusivity Requirements

April 8, 2022

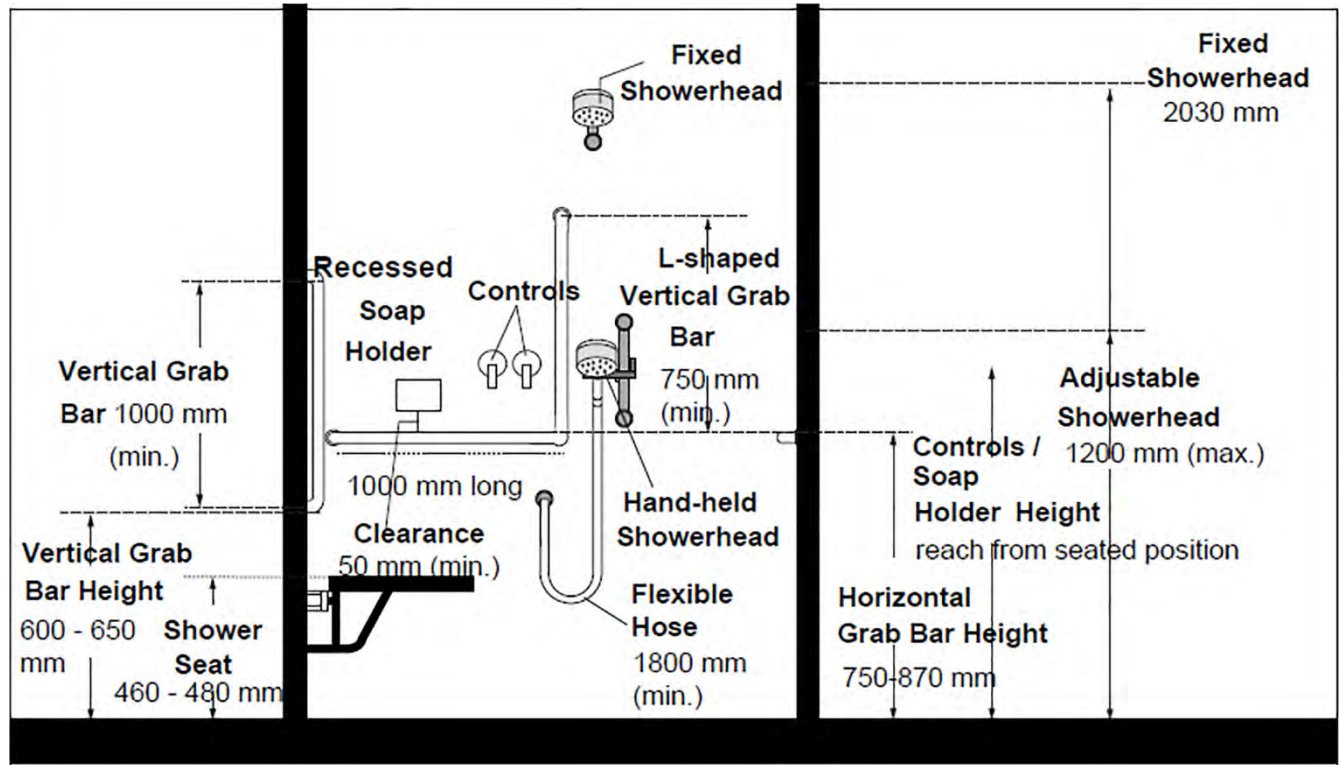

Figure 68: Shower Design - Section View

Durham Accessibility and Inclusivity Requirements

April 8, 2022

5.0 Systems, Controls and Communications

5.1 Controls and Operating Mechanisms

Rationale

Operating mechanisms that require a high degree of dexterity or strength will be difficult for many staff or public users to operate. They can also be obstacles to usability for children, individuals with arthritis, an amputee or even someone wearing gloves. Controls that require two hands to operate can also be difficult for some, particularly those with reach or balance limitations, or those who must use their hands to hold assistive devices like canes, crutches or walkers.

The placement of accessibility controls is integral to their usability. For the individual using a seated mobility assistive device, the height of the controls and the space to position the device in front of the controls are important. Controls placed high on a wall will also but unusable for children or people of shorter stature.

People who are blind or have vision loss will have difficulty with flush-mounted buttons, touch screens or controls that do not include tactile markings or accessible signage. Controls that contrast in colour from their background, including colour-contrasted raised letters, may be easier to find by people who are blind or have vision loss. People who are stressed or neurodivergent may find counterintuitive controls or graphics difficult.

Multiple forms of audible, visual and tactile cues to indicate and differentiate operating controls will benefit the widest range of users with varying disabilities (e.g. sensory / visual / cognitive).

Application

This section applies to typical interior and exterior controls and operating mechanisms provided for public and staff use throughout accessible routes and spaces.

Examples of typical controls and operating mechanisms related to interior and exterior environments include, but are not limited to:

- entrance call buttons or intercoms;
- emergency call systems related to parking areas;
- light switches;
- wall outlets / duplexes;
- fire or other alarm system controls (e.g. washroom emergency alarms);
- thermostats;
- door hardware; and
- plumbing fixture hardware (e.g. faucets and water closet flush controls).

Controls related to product and dispensing machines, such as food and beverage vending equipment, payment stations or parking and ticketing devices, touch screen devices for information and self-service kiosks and other activation devices are also required to be accessible.

5.1.1 Design Features

Ensure accessible controls and operating mechanisms address the following:

- a. are usable with closed fist and operable with one hand;
- b. do not require tight grasping, pinching of the fingers, or twisting of the wrist;
- c. can be used with force not more than 22.2 Newtons (maximum);
- d. where push-button type controls are provided, button surface has a minimum diameter of 13 mm and is not recessed;
- e. ensure controls are visible from a distance, based on use of high tonal contrast between operable parts and adjacent mounting surface (Figure 69);
- f. mount controls and operating mechanisms (Figure 70):
 - i. no lower than 400 mm high for all controls;
 - ii. at 1200 mm high for thermostat and manual fire alarm pull;

Durham Accessibility and Inclusivity Requirements

April 8, 2022

- iii. between 900 and 1100 mm high for all other controls and operating mechanisms;
- iv. so that they extend not more than 200 mm and not less than 900 mm high above the floor or vertical extended power door operators;
- g. located in prominent and obvious locations for easy identification;
- h. where possible, align controls at the same height; and
- i. where applicable, Braille should be provided at controls.

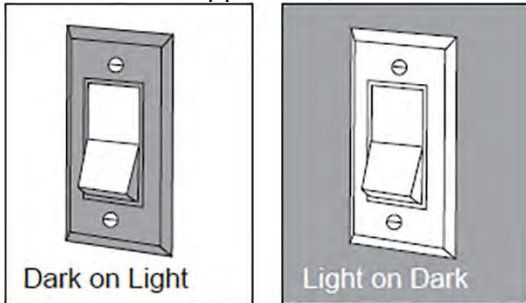

Figure 69: Tonal Contrast Between Background and Control

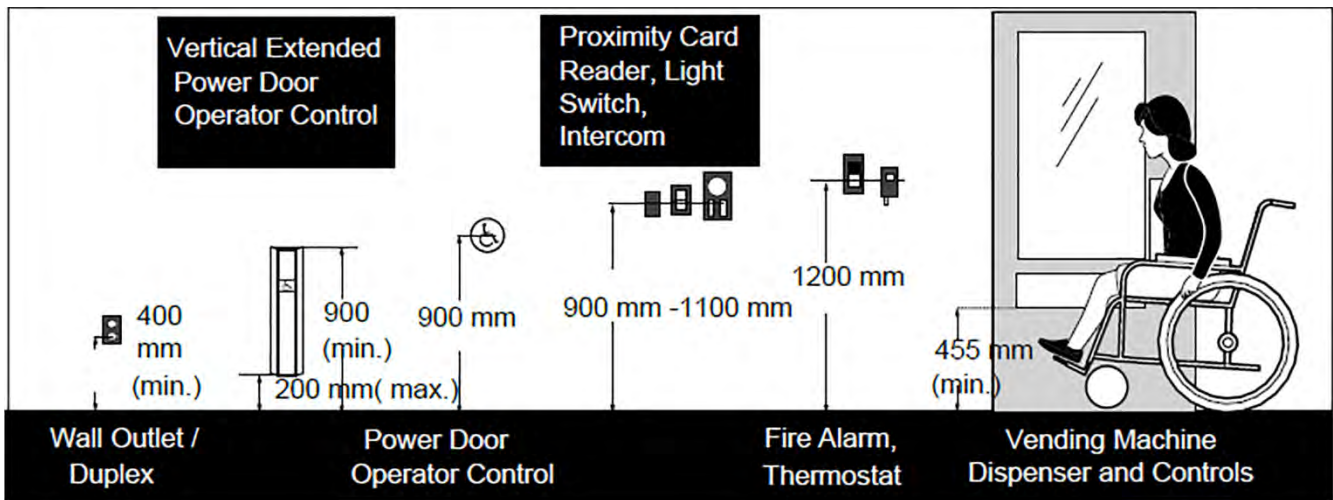

Figure 70: Control Mounting Heights - Elevation View

5.1.2 Floor Space and Reach Requirements

5.1.2.1 Floor Space Requirements

- a. provide a clear floor space to controls and operating mechanisms of:
 - i. 915 mm wide by 1370 mm depth for a forward approach; and
 - ii. 1525 mm wide by 915 mm depth for a side approach.
- b. the clear floor space in front of controls and operating mechanisms may overlap the adjacent interior accessible route;
- c. where space is available, provide a clear floor space with turning diameter of 1675 mm to allow both side and frontal approach for larger wheeled mobility aids such as powered scooters and wheelchairs.

5.1.2.2 Reach Requirements

For both a forward and side approach, ensure the following mounting heights of controls and operating mechanisms for suitable reach are provided:

- a. where there is no obstruction in front of controls and operating mechanisms:
 - i. no lower than 400 mm;
 - ii. at 1200 mm for thermostat and fire alarm pull controls; and
 - iii. no higher than 1100 mm for other controls and operating mechanisms; and
- b. where there is an obstruction of no more than 860 mm high:

Durham Accessibility and Inclusivity Requirements

April 8, 2022

- i. no higher than 1100 mm, which allows for a touch reach over a 600 mm deep obstruction or a grasp reach over a 500 mm deep obstruction (Figure 71a and b).

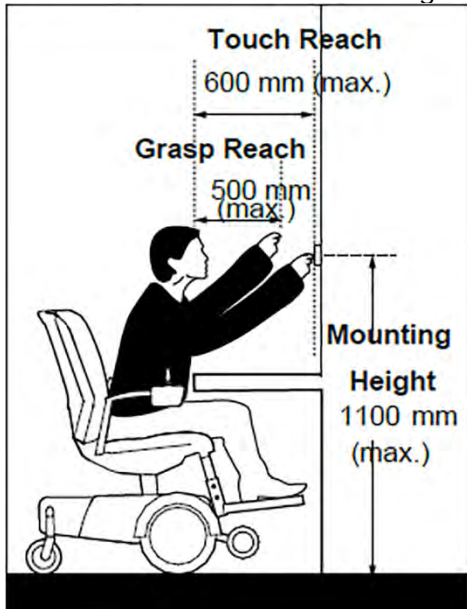

Figure 71a: Maximum Mounting Height for an Obstructed Forward Approach and Reach

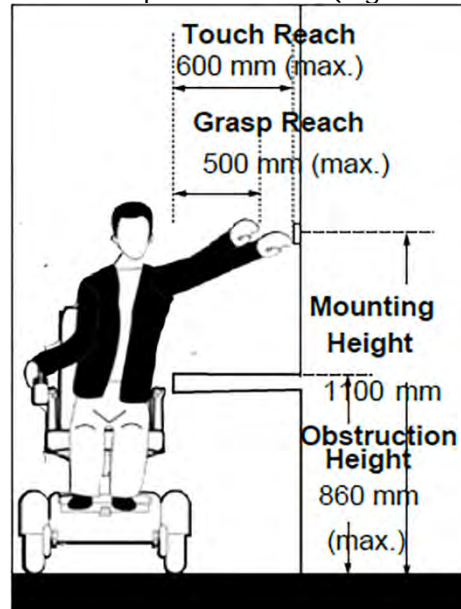

Figure 71b: Maximum Mounting Height over an Obstruction of 860 mm (maximum) for Side Approach and Reach

Durham Accessibility and Inclusivity Requirements

April 8, 2022

5.2 Assistive Listening Systems

Rationale

The provision of assistive listening systems is important for the range of individuals who may have difficulty hearing.

Adequate and controllable lighting is required for signage and at service desks where people who lip-read, or those who require increased task lighting, due to blindness or vision loss will be.

Application

This section applies to assistive listening systems required in assembly areas, including but not limited to classrooms, auditoriums, meeting rooms and theatres:

- with an area of 100 square metres or occupancy of seventy-five (50) or more fixed seats;
- where audible communication is integral to the use of the space; and
- where audio amplification devices are used.

Induction loops, infrared systems and F.M. radio frequency systems are considered acceptable types of assistive listening systems for people who are Deaf, deafened or have hearing loss. Wireless sound transmission systems, such as FM, infrared or magnetic induction loop, improve sound reception for the hard of hearing by providing amplification which can be adjusted by each user while blocking out unwanted background noise. These systems transmit a signal that is picked by special receivers available for use by people with a hearing disability, whether or not they use a hearing aid. The transmitter can be jacked into an existing system amplifier or used independently with microphones. The induction loop system requires users to sit in the area circumscribed by the loop; though installation of the loop is relatively simple, the installer should be knowledgeable about these systems if proper functioning is to be achieved. F.M. or infrared systems can be designed to broadcast signals which cover the entire room and, thus do not restrict seating to any one area.

Although portable systems (F.M. in particular) are available, these are best suited to small audiences. Generally, the systems installed in church halls, auditoriums, theatres and similar places of assembly are not easily portable, as they are installed in a fixed location by a sound technician and form an integral part of the sound system of the room or building.

Some facilities such as courtrooms may have unique requirements and specifications and require a detailed review prior to implementation.

Hard wired systems (where a jack is provided at a particular seat) will not meet the requirement in this section unless adequate provisions are made to accommodate people who use hearing aids. In choosing the most appropriate system, a number of factors must be taken into account including cost, installation and maintenance, suitability to the audience, ease of operation and the need for privacy. Information on designers and suppliers of these systems may be obtained from such organizations as the Canadian Hearing Society.

5.2.1 Design Features

For assistive listening systems, whether permanent or portable, are to ensure:

- a. system usability encompasses the entire floor area;
- b. system provides personal amplification control;
- c. system performs with or without the use of hearing aids;
- d. signage is provided with the International Symbol of Access for Hearing Loss pictogram to identify the availability of the assistive listening system and it is also marked with a 'T', where T-coil usage is available;
- e. where an induction loop system is installed, dimmer switches and other controls that incorporate transformer coils shall be located so as not to interfere with the audio induction loop;

Durham Accessibility and Inclusivity Requirements

April 8, 2022

- f. where infrared assistive listening devices are used, overhead incandescent lights shall be located so as not to cancel out the infrared signal at the receiver;
- g. where the listening system serves individual fixed seats, such seats shall be located within a 15m viewing distance; and
- h. receivers should be hearing-aid compatible and should interface with telecoils in hearing aids through the provision of neck loops.

5.2.2 Assistive Listening Systems

5.2.2.1 Permanent Assistive Listening Systems

Where permanent systems are provided:

- a. the minimum number of required receivers is equal to 4% of the total number of seats, but never less than two; and
- b. the minimum number of required receivers to be hearing aid compatible is 25% of the total number of receivers that are provided, but never less than one.

5.2.2.2 Portable Assistive Listening Systems

- a. provide at least one portable assistive listening system, with a minimum of two receivers included for facilities with assembly spaces on multiple floor levels (e.g. this provides enhanced flexibility for the systems to be available and used at different locations); and
- b. ensure portable assistive listening systems include hearing aid compatibility.



International Symbol of Access for Hearing Loss

Durham Accessibility and Inclusivity Requirements

April 8, 2022

5.3 Public Address Systems

Rationale

Public address systems need to be designed to best accommodate all users, especially those that may be deafened or hard of hearing. Announcements should be easy to hear above the ambient background noise of the environment and there should be no distortion or feedback. Background noise are to be minimized or reduced. Assistive listening systems and additional visual equivalents for individuals who are Deaf, deafened or have hearing loss who may not hear an audible public address system are important.

Application

This section applies to public address systems installed within a facility, as well as exterior, that provide information to the public and staff.

This section applies only to facilities where public address systems are provided to convey information, to the public or staff, as required for exterior / interior areas.

5.3.1 Design Features

- a. ensure sound level is above ambient background noise without distortion or feedback;
- b. music is not to be broadcast throughout the facility;
- c. all-point call systems are reserved for emergency only;
- d. to prevent confusion, ensure paging systems for use by staff or other key personnel are discreet and low in volume, and sound only at devices or locations where staff are expected to be located.
- e. consider zoning public address systems so that information can be directed to key locations only, to minimize background noise in other areas of the building; and
- f. mount speakers without projecting into or obstructing accessible routes and above head-level to provide effective sound coverage in required areas such as:
 - i. corridors;
 - ii. assembly and meeting rooms;
 - iii. recreational facilities
 - iv. entertainment and educational facilities; and
 - v. common use areas located in institutional settings.

Durham Accessibility and Inclusivity Requirements

April 8, 2022

5.4 Acoustics

Rationale

The acoustic environment of public buildings and spaces needs to accommodate the unique needs of people who are Deaf, deafened and hard of hearing as well as anyone who needs to differentiate essential sounds for communication or wayfinding from general background noise. The sound transmissions of different areas can be used as an orientation cue and help to navigate a space. A well-designed acoustical environment is to everyone's advantage.

Application

This section applies to the acoustic environment within a facility which can either enhance or hinder a user's experience. Auditory cues along circulation routes in large open spaces and dedicated areas can serve as wayfinding cues, especially for people with vision loss.

5.4.1 Design Features

To achieve a suitable acoustical environment which can provide additional wayfinding cues for people with vision and / or hearing loss:

- a. integrate the use of sound-reflective or sound absorbent materials to differentiate essential sounds from general background sounds;
- b. select floor, wall and ceiling finishes to ensure that occasional noise is not unintentionally amplified (e.g. avoid hard floor surfaces such as marble and terrazzo will allow each footstep to be heard by people who are blind or have vision loss, but too much additional noise may add confusion for people with sensory disabilities including those who are Deaf, deafened or with hearing loss);
- c. design ceiling shapes so that echoes do not occur (Note: Domed shaped ceilings may distort sound);
- d. minimize all background noise (e.g. fans, mechanical systems, air conditioners and diffusers) in meeting rooms and assembly areas where spoken word is key to understanding proceedings;
- e. integrate and include adequate sound insulation in room and space design; and
- f. install a permanent inductive loop or similar assistive listening system for high use buildings and areas, especially where the surrounding environment may be noisy.

Durham Accessibility and Inclusivity Requirements

April 8, 2022

5.5 Security Systems

Rationale

In many cases, older persons and people with disabilities may be considered to have a higher degree of vulnerability and therefore seek more reassurance and inherent security. Items such as adequate lighting, duress call boxes and accessible signalling devices promote this security.

Emergency signalling devices are important in all individual washrooms where the potential for a fall is increased and an individual may be alone.

Where card-access systems are selected as a means of entry to particular facilities or spaces, the systems and components selected should be suitable for use by people with varying abilities, including people with reduced manual dexterity, poor vision or limited mobility. Proximity card reader systems are preferred at secured entry / exit areas to accommodate diverse user's abilities.

Application

This section applies to typical security systems (e.g. proximity card readers, alarm systems) which are used to provide and limit access to areas of a facility.

Designers are to coordinate with Corporate Security to ensure the requirements of this section are met.

5.5.1 Design Features

Where users control independent entry or exiting to secured areas of facilities:

- a. locate controls between 900 mm to 1100 mm from the floor;
- b. mount controls at least 600 mm clear of the arc of any door swing (Figure 72);
- c. where electronic keypads or push-button systems are provided, ensure buttons are raised from surface, mounted on surface with high tonal contrast and have raised numerals or letters to assist with vision loss;
- d. ensure both audible and visual indicators are provided to alert users when access has been granted or denied;
- e. where proximity card readers (e.g. swipe cards) are used at doors equipped with power door operators, ensure activation of both systems is synchronized; and
- f. provide high tonal contrast on system controls, compared to mounting surface.

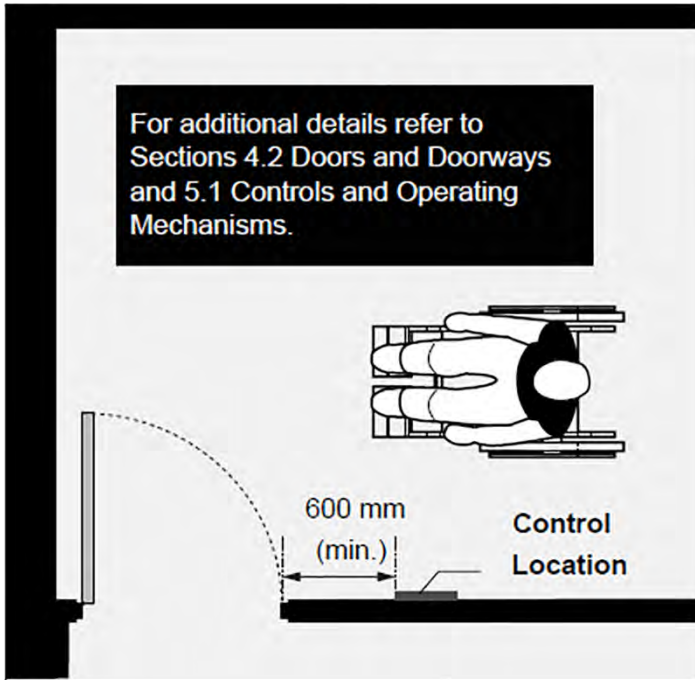

Figure 72: Proximity Card Reader Location - Plan View

Durham Accessibility and Inclusivity Requirements

April 8, 2022

5.6 Fire and Life Safety Systems

Rationale

Fire and life safety systems are key for all facilities but especially important in facilities providing specialized services or programs to seniors and people with disabilities. Seniors and people with disabilities are groups at greater risk and may require additional assistance or accommodation to evacuate a facility.

In order to be usable and accessible to all individuals, emergency exits must include the same accessibility features as other doors specified in 4.2. The doors and routes must also be marked in a way that is accessible, including those who may have difficulty with literacy, such as children or people speaking a different language. People who are blind or have vision loss will need a means of quickly locating exits – audio or talking signs could assist. Consider providing photoluminescent signage (i.e. visible in dark or smoke-filled environments), in addition to regulatory exit signage, throughout exit stairs and at strategic locations along exit routes to assist with evacuation.

In the event of fire when elevators cannot be used, areas of rescue assistance are an asset to anyone who would have difficulty using stairs.

Visual alarms are essential safety features for individuals who are deaf, deafened or hard of hearing such that they would not hear an audible alarm.

Application

This section applies to fire and life safety systems addressing the needs of people with varying disabilities in emergency situations. Key components of typical fire and life safety systems include, but are not limited to:

- evacuation plans
- alarm signals (both audible and visual);
- 'Areas of Refuge'; and
- emergency exits.

The information in this section is provided as an additional resource to support other code and fire / life safety requirements that may be mandatory.

For public facilities, visual alarm signals shall be installed in common use areas including, central lobbies, corridors, main assembly areas (e.g. auditoriums, conference rooms and cafeterias) and places where a person may be alone (e.g. universal washrooms).

The provision of additional spaces for accommodating mobility aids in an 'Areas of Refuge' is determined by facility occupancy and level of use. Stairwells and elevator lobbies are typically used for 'Areas of Refuge', if properly designed with all required features and floor space to accommodate mobility aids. Detailed review and design is required for provisions in any type of facility, existing or new.

5.6.1 Fire Safety and Evacuation Plans

- a. provide a fire and life safety evacuation plan that addresses the needs of users with varying disabilities:
 - i. for facilities with floors above or below grade, develop a fire safety and evacuation plan, indicating in detail the preferred evacuation strategies for people with disabilities (e.g. "Buddy System" where staff can help co-workers with disabilities evacuate);
 - ii. ensure the base of evacuation plans are posted no higher than 1200 mm from the floor (Figure 73);
 - iii. ensure evacuation plans incorporate a font size of 12 point (minimum);
 - iv. ensure evacuation plans are available in alternate formats; and
 - v. provide signage to identify evacuation plans
- b. mount controls and operating mechanisms

Durham Accessibility and Inclusivity Requirements

April 8, 2022

- i. between 900 mm and 1100 mm from floor for emergency and life safety controls and operating mechanisms such as fire extinguishers, first aid kits and defibrillators; and
- ii. at 1200 mm high from floor for manual fire alarm pull
- c. Where appropriate, a fire fighter's elevator that can be operated by fire department personnel during emergencies should be installed.

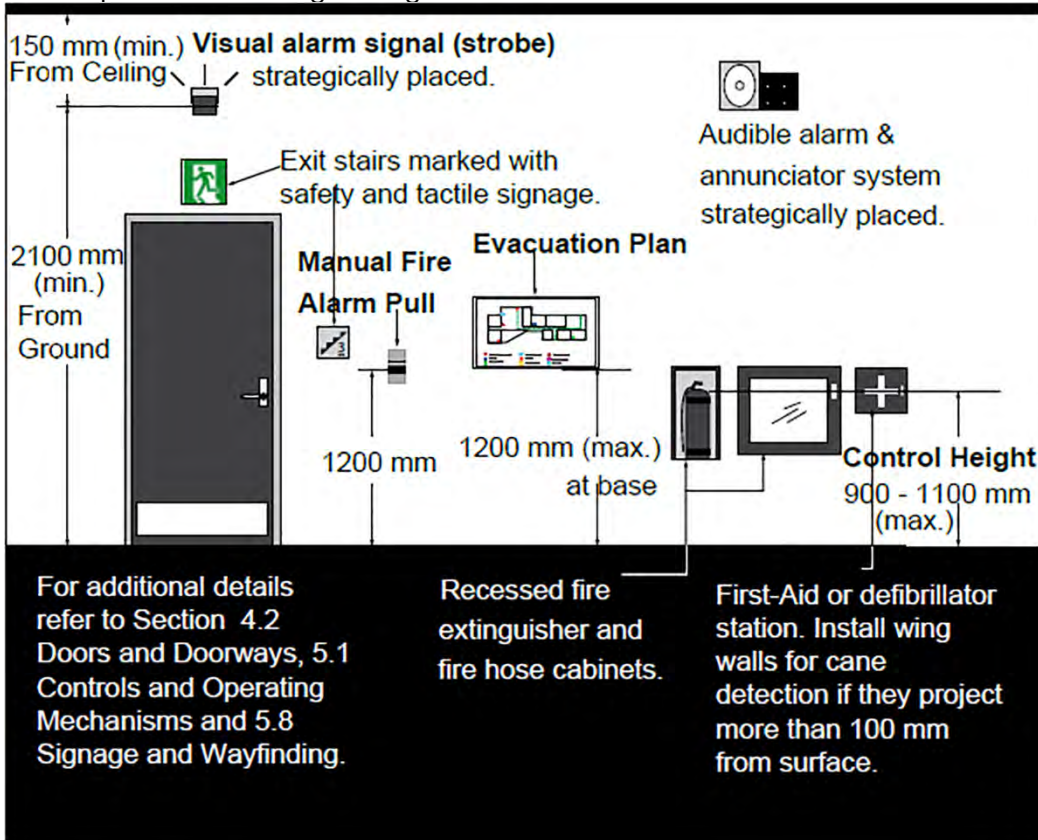

Figure 73: Fire Safety and Evacuation Features - Elevation View

5.6.2 Visual Alarm Signals

Where visual alarm signals are provided for users with hearing loss:

- a. integrate visual alarm signals with required audible fire alarm system, including during retrofit projects where feasible;
- b. mount appliance at 2100 mm (minimum) above the floor level within the space or 150 mm below the ceiling, whichever is lower (Figure 73);
- c. where visual alarm signals are provided in any common space, public corridor, hallway, lobby or room, ensure they are placed no more than 15 metres apart, on the horizontal plane;
- d. install visual alarm signals so that the signal from at least one device is visible throughout the floor area or portion of it in which they are installed (Note: Optimal visual alarm signal placement requires formal study for unique environments, including multi purpose facilities, libraries, convention / meeting rooms and other facility types to ensure signals are visible from all required areas.);
- e. ensure light and flashing features are based on the following criteria:
 - i. use a xenon strobe type or equivalent for light or lamp fixture;
 - ii. ensure clear or nominal white colour (e.g. unfiltered or clear filtered white light);

Durham Accessibility and Inclusivity Requirements

April 8, 2022

- iii. provide maximum pulse duration of 0.2 seconds, with a maximum duty cycle of 40 percent;
 - iv. ensure the intensity of the visual alarm signal raises the overall light level sharply, but not so intense as to be unsafe for direct viewing;
 - v. ensure a flash intensity of 75 candela (minimum) with a flash rate between 1 Hertz (minimum) and 3 Hertz (maximum); and
 - vi. synchronize visual alarms that are located in the same proximity to flash at the same time (Note: To reduce the likelihood of triggering an epileptic seizure or other photosensitive reaction from multiple unsynchronized visual strobe lights, ensure the flash rate is less than 2 Hertz.);
- f. where fire alarm systems cannot be upgraded, consider the provision of portable, vibrating pager systems for users with vision and hearing loss; and
 - g. Meet NFPA section 18.5.3 requirements.

5.6.3 Areas of Refuge

Where an "Area of Refuge" is included as a component of a facility's fire safety and evacuation plan for people with disabilities:

- a. locate on an accessible route which is served by an exit or fire fighter's elevator;
- b. locate clear of any adjacent door swing and away from pedestrian exit route(s);
- c. ensure areas of refuge are easy to identify and are designated with signage (e.g. large print, tactile features stating 'Area of Refuge' and marked with the International Symbol of Accessibility);
- d. ensure a clear floor space of at least 1675 mm by 1675 mm is provided to accommodate users of mobility aids;
- e. provide protective enclosure for a minimum of one-hour;
- f. provide a two-way, accessible communication system supported by the facility's back up power supply and linked to the designated fire control centre / panel;
- g. ensure communication system is marked with signage and includes both audible and visual notification devices to indicate "help is on the way";
- h. provide separate emergency lighting and ventilation systems supported by a backup generator; and
- i. It is recommended to provide emergency electrical power to ensure adequate emergency lighting levels for the use of elevators and key operating components or other systems during a power outage, in all major areas of the facility, along all paths of travel to exits and all Areas of Refuge.

Durham Accessibility and Inclusivity Requirements

April 8, 2022

5.7 Lighting

Rationale

Variations in lighting levels can be confusing to many older adults, people with cognitive disabilities and people with vision loss. To avoid this, artificial lighting and natural light sources need to provide comfortable, evenly distributed light at all service and working areas, in all circulation routes and in all areas of potential hazard. Also, outdoor lighting should be provided at entrances, along frequently used access routes and at outdoor amenities.

Application

This section addresses lighting requirements for both interior and exterior environments.

For additional information on lighting requirements refer to the Illuminating Engineering Society's (I.E.S.) "The Lighting Handbook", latest version.

The Canadian National Institute for the Blind (CNIB) recommends increasing I.E.S. suggested lighting levels by a range of 25 to 50 percent to address the needs of people with vision loss.

5.7.1 Lighting Level Requirements

For lighting level requirements for interior and exterior environments, designers must refer to the appropriate reference document for detailed requirements. Reference documents include:

- a. Durham Region Street Lighting Design Manual;
- b. Ontario Building Code; and
- c. Illuminating Engineering Society of North America "The Lighting Handbook".

5.7.2 Exterior Lighting

- a. ensure lighting sources are located at or beside all ramps, steps and stairs to illuminate and identify surfaces, treads, risers, nosings and handrails;
- b. ensure all lighting over pedestrian routes is evenly distributed and provides a reasonable colour spectrum while minimizing any shadows casted;
- c. provide supplementary lighting to highlight all wayfinding signage, as required;
- d. ensure lighting fixtures or posts do not encroach on accessible routes /paths of travel;
- e. ensure low-level lighting standards are mounted high enough to clear normal snow accumulation heights; and
- f. ensure overhead light fixtures are mounted with clear headroom of 2100 mm (minimum).

5.7.3 Interior Lighting

- a. use natural light wherever possible to illuminate entrances, corridors and key workspaces; however, avoid designs that results in direct glare reflected from flooring or work surfaces;
- b. integrate sources of both artificial and natural lighting to provide comfortable, evenly distributed light at working surfaces and throughout circulation routes;
- c. ensure lighting design allows an illumination quality that is as close to a full spectrum as possible to aid in identifying edges and colour contrasts which are used as wayfinding cues (this ensures the warm end of the spectrum provides appropriate colour definition);
- d. ensure any leading edge of stairs, steps, ramps or escalators are evenly lit;
- e. ensure sources of light (natural or artificial) are not positioned at the ends of corridors or behind people at reception areas or counters; and
- f. use transitional lighting options (higher artificial lighting levels near the entrance in daylight and lower levels after dark) when entering the facility since eyes may require an adjustment time from a brighter exterior to a darker interior environment or vice versa.

5.7.4 Additional Considerations: Issues Related to Glare

- a. select lighting sources, materials and finishes that do not reflect glare, including implementing strategies to control natural lighting sources wherever possible;
- b. ensure floor surface finishes such as vinyl, terrazzo and ceramic tile, mosaic or other materials have a matte or satin finish to prevent and minimize glare;

Durham Accessibility and Inclusivity Requirements

April 8, 2022

- c. provide matte or satin wall finishes (e.g. paint, vinyl coverings, stone, marble, wood, plastic or laminate) to prevent and minimize glare;
- d. provide curtains, blinds, screens or other strategies to shield bright, natural lighting sources, especially where direct sunlight may cause glare;
- e. select light fixtures that prevent or minimize any potential or direct glare (e.g. with diffusers, lenses, or recessed light sources);
- f. where surface mounted fluorescent ceiling lights are used (e.g. in corridors), it is generally recommended that they have darkened sides (e.g. wrap-around lenses are not recommended) and that they are positioned at right angles to the path of travel; and
- g. avoid the use of light fixtures with multiple pinpoints of high intensity illumination as they may add an unnecessary source of glare and leave an after image on the retina of people with vision loss (Note: High intensity light sources such as quartz, halogen or other pinpoint sources can produce reflected points of glare on shiny surfaces.).

Durham Accessibility and Inclusivity Requirements

April 8, 2022

5.8 Signage and Wayfinding

Rationale

Signage is to be simple, uncluttered and incorporate plain language. The use of graphic symbols is important for individuals such as children; those with a limited literacy level, or for those who may not be fluent in English.

High colour and tonal contrast make signage easier for anyone to read, particularly someone who is blind or has vision loss. The intent of any symbol used must be evident, culturally universal and not counterintuitive. To enhance readability, raised tactile lettering should incorporate edges that are slightly smoothed.

Application

This section applies to signage and wayfinding strategies, where provided in exterior and interior environments.

Recognizing that signage programs and wayfinding strategies are customized based on facility types and use of space, the information and criteria in this section is provided as a starting point.

There are different types of signage for various purposes:

- regulatory signs, which include prohibition signs denoting order forbidding an action, and mandatory signs which denote an order requiring an action;
- warning signs such as caution and danger signs denote a potential hazard and a definite hazard, respectively; and
- identification signs, which include rooms, titles, names or numbers are provided for general orientation or specific information, such as washrooms, routes of egress, stairwells, doorways or offices.

5.8.1 Signage

5.8.1.1 Design Features

- a. ensure signage surfaces have matte, eggshell or non-glare finish;
- b. ensure suitable lighting such that there are no obtrusive shadows cast onto the signage;
- c. ensure signage is of uniform design;
- d. provide colour contrast between signage and mounting surfaces;
- e. where used to give the same type of information within the same facility, ensure signage is consistently shaped, coloured and positioned;
- f. ensure information on signage is short and simple;
- g. ensure signage is consistently located, including height considerations for overhead or wall-mounted signs and uniform placement of identification signs for facilities and services;
- h. where possible, mount signs at eye level since it allows people, especially those who are near-sighted, to get closer to read the sign;
- i. where facilities or elements, including but not limited to washrooms, elevators, telephones, information kiosks, routes, 'Areas of Refuge', and parking facilities are accessible, provide signage with the International Symbol of Accessibility to designate as accessible (Figure 74);
- j. avoid using vertical wording and electronic scrolling signage, and where scrolling signage has to be used, ensure characters and symbols move slowly across the screen;
- k. where illuminated signage is provided, avoid using red, blue or green L.E.D.s on a black background as they are unreadable for most people with vision loss; and
- l. provide lighting in accordance with Section 5.7 Lighting requirements, as applicable at signs.

Durham Accessibility and Inclusivity Requirements

April 8, 2022

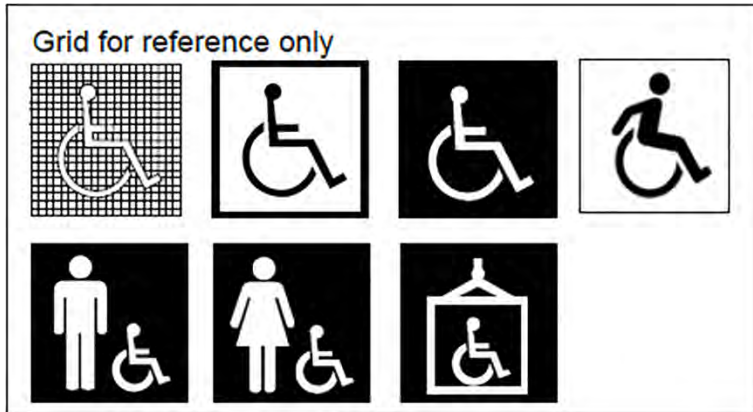

Figure 74: Examples of International Symbols of Accessibility

5.8.1.2 Character Features and Sizes

- ensure text characters (e.g. letter or number) are sans serif font type and have Arabic numerals;
- avoid the use of very fine type or very thick type font;
- use a combination of lower case and upper case letters since is easier to read than using all upper case letters;
- provide width to height ratio between 3:5 and 1:1 (Figure 75);
- provide stroke width to height ratio between 1:5 and 1:10;
- ensure characters are not italic, oblique, script, highly decorative or of other unusual forms;
- provide high tonal contrast between text characters and background surface;
- ensure the minimum character height is provided as per viewing distance as identified in Table 10; and
- use an uppercase "X" for character measurement.

Table 10: Character Height Relative to Viewing Distances

| Minimum Character Height (mm) | Maximum Viewing Distance (mm) |
|-------------------------------|-------------------------------|
| 200 | 6,000 |
| 150 | 4,600 |
| 100 | 2,500 |
| 75 | 2,300 |
| 50 | 1,500 |
| 25 | 750 |

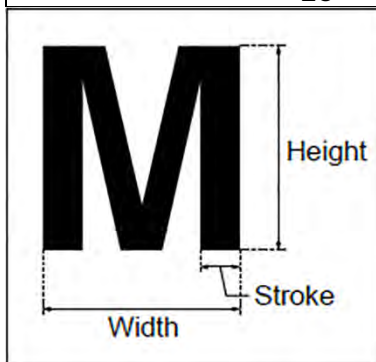

Figure 75: Character Features and Sizes

Durham Accessibility and Inclusivity Requirements

April 8, 2022

5.8.1.3 Pictograms and Symbols

Pictograms and symbols are used to complement text information and identify important facility features, elements or services, including information desks, public washrooms, and elevators.

Where pictograms are used:

- ensure pictogram has a field height of 150 mm (minimum);
- provide text descriptors and braille directly below the pictogram field and not in the pictogram field;
- provide high tonal contrast between pictogram and the background
- use the International Symbol of Accessibility to identify accessible facility features, spaces, elements and amenities (Figure 74); and
- use recognized and standardized symbols for accessibility features or other key building elements (e.g. washrooms, telephones and elevators) to facilitate wayfinding for all users (Figure 76).

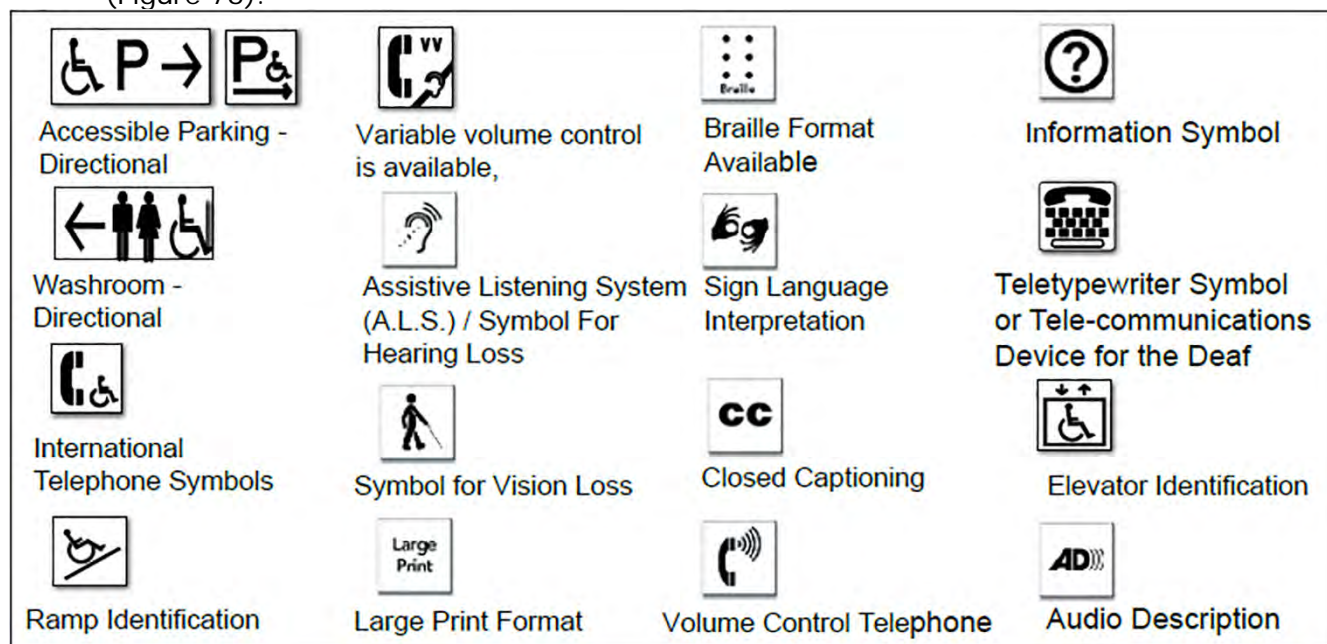

Figure 76: Example of Typical Pictograms and Symbols

5.8.1.4 Braille

Where braille is provided on signage:

- use uncontracted braille for signs that have 10 words or less and contracted braille for signs more than 10 words;
- ensure braille dots have a domed or rounded shape;
- locate immediately below the corresponding text (e.g. room numbers, names) and / or pictogram;
- ensure uppercase and lowercase braille matches written text precisely; and
- where text is multi-lined, place braille below the entire text.

5.8.2 Tactile Signage

Signage with tactile features (e.g. braille, raised characters / text, symbols or pictograms) are designed to be read by touch to identify permanent rooms and spaces. These features are not required for overhead or suspended signage (e.g. directional information).

In larger and complex buildings, such as recreation centres, provide tactile maps on each floor, close to the major point of arrival to the floor (e.g. elevator lobby) to assist with wayfinding for users with vision loss (Figure 79).

Durham Accessibility and Inclusivity Requirements

April 8, 2022

5.8.2.1 Design Features

Where tactile characters are provided:

- a. ensure text characters (e.g., letter or number) and pictograms (where provided) are raised between 0.8 to 1.5 mm above the surface (Figure 78);
- b. ensure the edges of the text characters are gently rounded;
- c. provide high tonal contrast between the tactile characters and the background surface;
- d. ensure all raised text characters, pictograms or symbols are accompanied by equivalent description in braille;
- e. where pictogram is provided, ensure they are 150 mm (minimum) high; and
- f. for text characters (e.g. letter or number):
 - i. ensure they are sans serif font and Arabic numerals;
 - ii. ensure height of characters are between 16 and 50 mm; and
 - iii. ensure text is entirely in upper case lettering as it is easier to read by touch, compared to a combination of upper and lower case letters.

5.8.2.2 Mounting Locations

Where signage with tactile features is provided:

- a. mount at 1200 mm (minimum) high, measured from the baseline of the lowest tactile character and 1500 (maximum) high, measured from the baseline of the highest tactile character (Figure 77);
- b. where provided at a door, install consistently on the wall beside the latch edge of door, 150 mm +/- 10 mm from the door frame;
- c. where provided at double doors with one active leaf, mount signage to the right of the right hand door;
- d. where there is no wall space at the latch side of a single door or on the right side of the double door, install signage on nearest adjacent wall;
- e. avoid mounting signage directly on external glazing where possible as it may reduce visibility and legibility of text;
- f. install to allow users to approach within 100 mm of sign location, clear of any door swing or protruding objects;
- g. mount so that a clear floor space of 455 mm by 455 mm (minimum), centred on the tactile characters is provided beyond the arc of any door swing between the closed position and the 45 degree open position; and
- h. ensure a clear wall area of 75 mm wide (minimum) around the sign is provided.

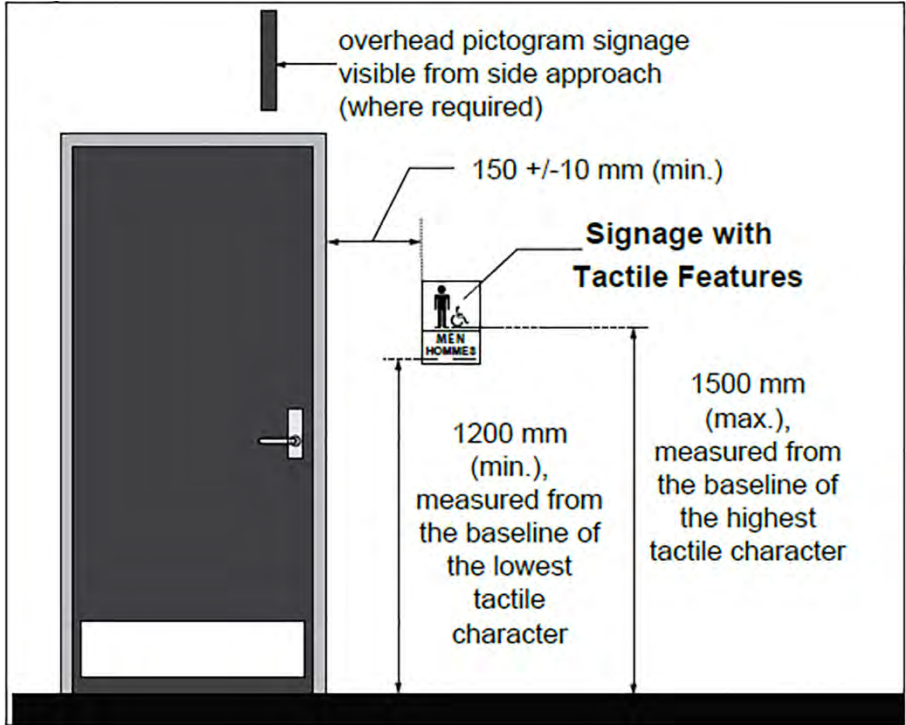

Figure 77: Mounting Location of Signage with Tactile Features - Elevation View

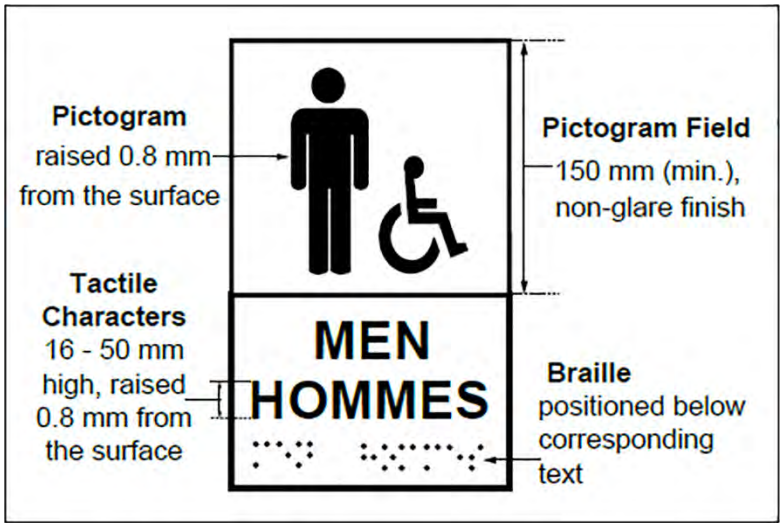

Figure 78: Signage with Tactile Features

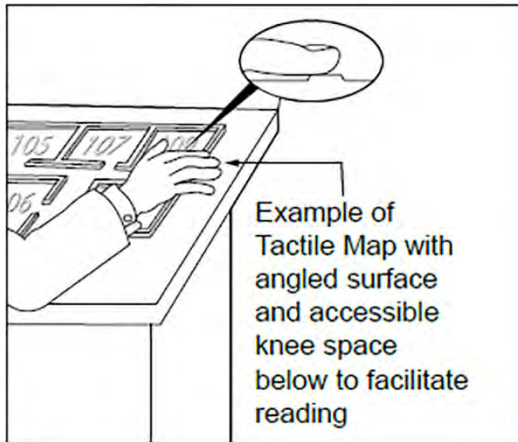

Figure 79: Tactile Map

5.8.3 Wayfinding Principles

- a. ensure consistent design, strategic placement and ideal mounting heights at key decision-making points along accessible routes for all signage;
- b. provide high tonal contrast between signage and mounting surfaces for full visibility;
- c. ensure there is no information overload or cluttering of signage to avoid confusion;
- d. avoid placing suspended signs against a light source to ensure full visibility (e.g. at the end of corridors which have windows, glass doors or window walls);
- e. mount signs so that they face the direction of travel as they are easiest to notice and read for people who might have limitation moving their head or have reduced peripheral vision; and
- f. control the use of temporary signage, which can render other relevant and accessible signage ineffective, through management procedures / protocols.

Durham Accessibility and Inclusivity Requirements

April 8, 2022

5.9 Windows

Rationale

Broad expanses of glazing in screens, sidelights and doors can be difficult to detect. While this may be a particular concern to people who are blind or have vision loss or those who are blind, it is possible for anyone to walk into a clear sheet of glazing especially if they are distracted or in a hurry.

People who use wheelchairs or scooters experience the facility from a seated position thereby lowering their eye level and reach range. This necessitates the need for lower sill heights to ensure equality of views as well as the provision of easily reached operating mechanisms. Window controls and operating devices are to respect the differences of amputees, hand strength or dexterity encountered with different types of disabilities, including arthritis.

Application

This section applies to windows, glazed screens, vision panels in doors, and fully glazed sidelights intended for viewing or that are required for ventilation.

Accessibility requirements are applicable to windows that are intended for use by facility occupants, staff or public.

5.9.1 Design Features

For windows, glazed screens and vision panels designed for the purpose of viewing:

- a. provide clear floor space of 915 mm wide by 1370 mm deep (minimum) for forward and 1525 mm wide by 915 mm deep (minimum) for side approach by users of mobility aids;
- b. where possible, provide a floor space with turning diameter of 1675 mm to accommodate larger mobility aids;
- c. locate bottom sill height no more than 1100 mm above the finished floor;
- d. where ventilation controls are provided, mount between 400 mm and 1100 mm above the finished floor to be reachable from a seated position (Figure 80);
- e. do not locate horizontal structure (e.g. mullion or other visual obstruction between 900 mm and 1300 mm above the floor; and
- f. where wall systems include extensive use of glazing, provide horizontal markings strips:
 - i. 50 mm in height, extending full width of glazed area, mounted between 1350 mm and 1500 mm above finished floor;
 - ii. where there is extensive glazing, consider providing a second strip at a lower level, between 850 to 1000 mm high above finished floor level; and
 - iii. ensure high tonal contrast is provided for users with vision loss.

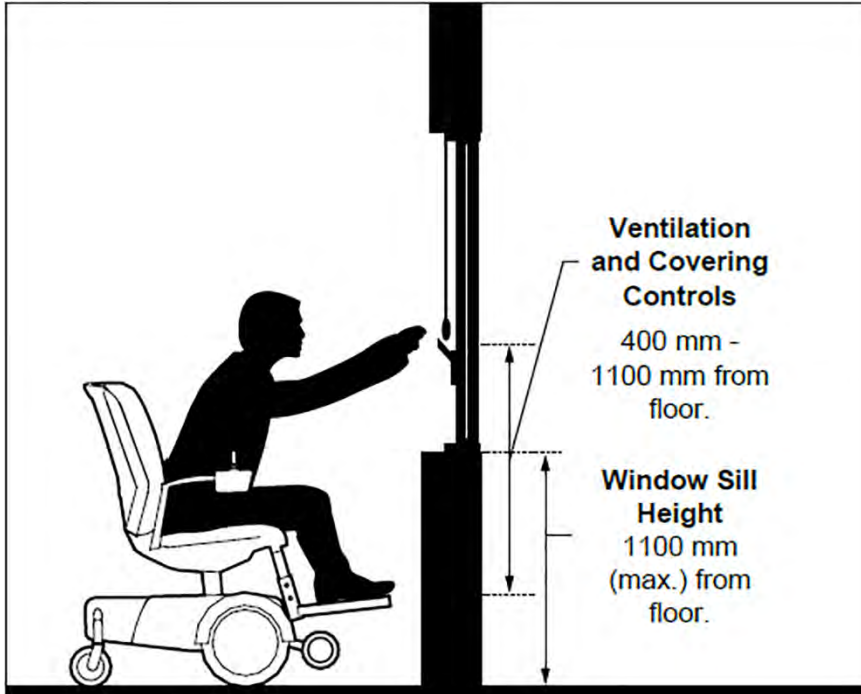

Figure 80: Window Design Features - Elevation View

Durham Accessibility and Inclusivity Requirements

April 8, 2022

6.0 Special Facilities and Spaces

6.1 Assembly Areas

Rationale

The clear floor space for inclusive designated accessible seating spaces are required for individuals unable to use typical seating. Accessible seating spaces need to provide adequate space to manoeuvre a mobility device as large as a scooter and are not to be limited to one location. Designated companion seating should also be provided. Guards placed around an accessible seating space should not interfere with the line of sight of someone. A choice of seating locations and ticket price range should be available.

Providing only one size of seating does not reflect the diversity of body types of our society. Seating with increased legroom will better suit individuals that are taller. Seats with removable armrests (adaptable seating) are helpful for people of larger stature as well as individuals that prefer to transfer to the seat instead of sitting in their mobility assistive device.

Application

This section applies to assembly areas in both interior and exterior environments. Common assembly areas where accessible seating spaces are required are identified in Table 11.

Table 11: Common Assembly Areas

| Civic | Entertainment / Cultural | Educational | Sports |
|-----------------------------------------------------------|---------------------------------|-----------------------------|-------------------|
| Council Chamber | Theatre | Lecture Hall | Arena |
| Public Meeting or Hearing Room | Places of Worship | Classroom | Stadium |
| Auditorium | Performing Arts Centre | Conference / Symposium Room | Gym |
| Multi-purpose room (e.g. Community or Recreation Centres) | Museum | Stage / Podium | Grand Stand Stage |

6.1.1 Design and Layout

- ensure lighting level is evenly distributed throughout all accessible routes and accessible seating spaces;
- ensure a consistent accessible path of travel of 1100 mm (minimum), 1800 mm preferred, throughout space for circulation;
- provide accessible seating options for users of mobility aids;
- provide adaptable seating options, with armrests that flip up and down at the end of aisle seats, to provide assistance to people transferring from mobility aids;
- provide assistive listening systems designed for the type of venue and audience; and
- ensure all audio-visual equipment, features, controls and related technology are usable by all participants and staff, where provided, including the provision of instructions and guidance in alternative formats.
- where lighting is dimmed (e.g. theatres or performing arts centre), ensure steps and accessible routes are illuminated (e.g. marked with lighting strips) to assist with identification.

6.1.2 Accessible and Adaptable Seating

6.1.2.1 Provision

Where fixed seating is available in assembly occupancies:

provide accessible seating spaces for users of mobility aids and adaptable seating based on total number of fixed seats, as identified in Table 12:

Table 12: Accessible and Adaptable Seating Requirements in Assembly Areas

Durham Accessibility and Inclusivity Requirements

April 8, 2022

| Total Number of Fixed Seats | Minimum Number of Accessible Seats | Minimum Number of Adaptable Seating |
|-----------------------------|------------------------------------|------------------------------------------------------------|
| Up to 20 | 2 | 1 |
| 21 to 40 | 2 | 2 |
| 41 to 60 | 2 | 3 |
| 61 to 80 | 2 | 4 |
| 81 to 100 | 3 | 5 |
| Over 100 | 3% of seating capacity | the greater of 5 seats or 5% of the aisle seating capacity |

6.1.2.2 Accessible Seating Spaces

- a. install directional signage in prominent locations to identify location of accessible seating spaces;
- b. locate spaces adjoining an accessible path of travel, without infringing on egress from any row of seating;
- c. provide at least one fixed companion seat adjacent to accessible seating spaces and within the same row, ensuring shoulder alignment for users sitting beside each other (Figure 81);
- d. when entering from side, ensure clear floor space to accessible seating spaces is 1525 mm wide by 915 mm deep (minimum) (Figure 83);
- e. when entering from rear or front, ensure clear floor space to accessible seating space is at least 915 mm wide by 1370 mm deep (minimum);
- f. ensure at least two accessible seating spaces are provided side by side;
- g. distribute seating locations to provide for a variety of admission prices;
- h. where accessible seating spaces are situated as part of the designated seating plan, provide a choice of viewing location and ensure there is a clear view of the event taking place (Figure 83);
- i. where accessible seating spaces are provided on an elevated platform (Figure 82), ensure the lines of sight are:
 - i. comparable to those for all viewing positions;
 - ii. not reduced or obstructed by standing members of the audience; and
 - iii. free of any obstructions (e.g. any barriers, handrails, guardrails or columns);
- j. where space is available, provide an increased riser height to ensure suitable sight lines and comparable views when users in front are in standing position; and
- k. ensure accessible seating spaces are positioned so that they do not obstruct sight lines of other users either sitting or standing.

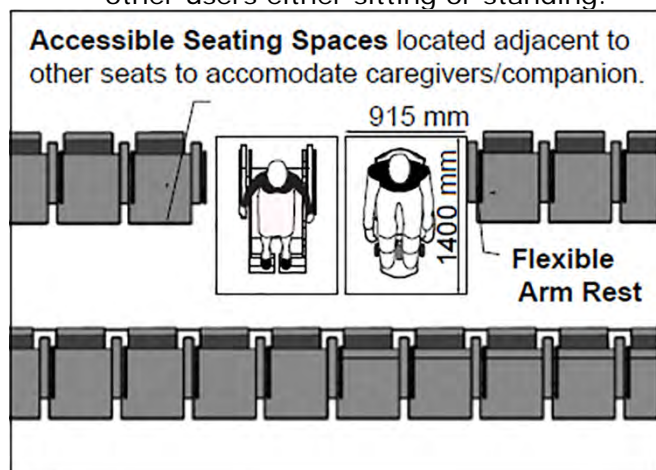

Figure 81: Accessible Seating Space Dimensions

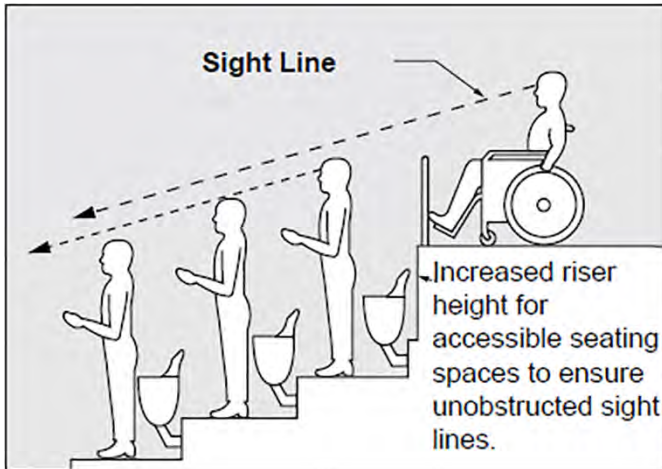

Figure 82: Lines of Sight

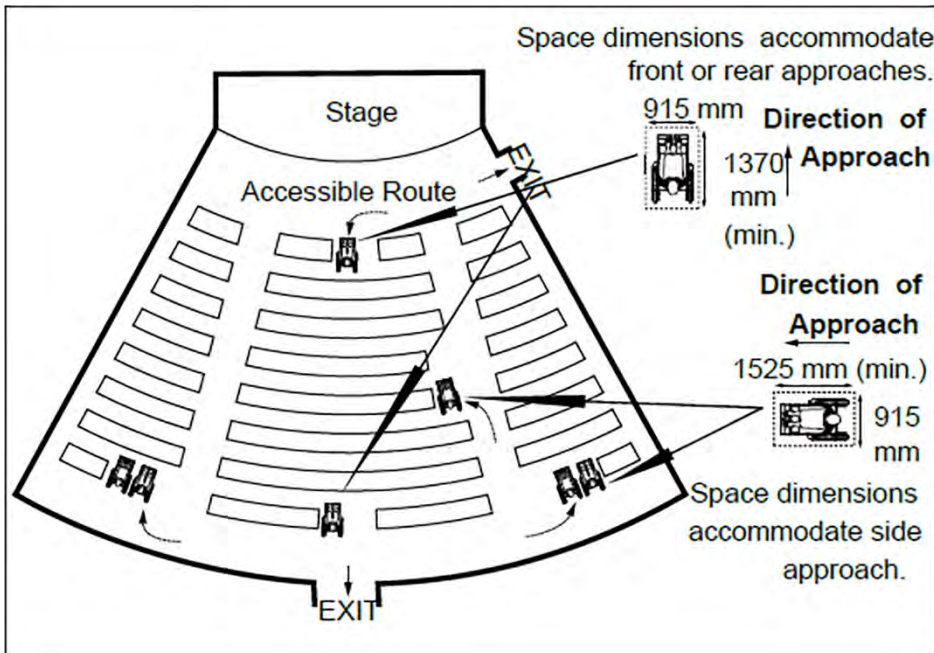

Figure 83: Accessible Seating Plan - Example of Viewing Positions

6.1.2.3 Adaptable Seating

- locate adjacent to an accessible route without infringing on egress from any row of seating or any aisle requirements;
- equip with a movable or removable armrest on the side of the seat adjoining the accessible route; and
- locate as part of the designated seating plan and provide a choice of viewing location with a clear view of the event taking place.

6.1.2.4 Storage for Mobility Aids

- ensure at least one (1) storage space where not more than 200 fixed seats is provided and a minimum of two (2) storage spaces, where more than 200 fixed seats are provided;
- provide a clear floor space of 915 mm wide by 1370 mm deep (minimum) for each space; and
- locate storage space on the same level and in proximity to the accessible seating spaces and seats designated as adaptable seating.

Durham Accessibility and Inclusivity Requirements

April 8, 2022

6.2 Meeting and Multi-Purpose Rooms

Rationale

Meeting and multi-purpose rooms are typically intended to be flexible (e.g. with movable seating) in order to accommodate a wide range of uses, group sizes (e.g. dependent upon overall size of space) and the needs and preferences of the widest range of participants as possible. With movable seating available at all times, the intent is that the clear floor space for at least 2 accessible seating spaces will be made available, for example with one on each side of a table for smaller spaces. For larger spaces, accessible floor spaces are expected to be possible on all sides of a table. When a meeting room is not in use, seats are to be removed from accessible seating spaces but stored in locations that ensure the accessible path of travel throughout room is not obstructed.

Some facilities may limit uses due to the classification and type of building, but maximum flexibility is expected to be built into the design to accommodate the changing needs of occupants over time. All people, but particularly those with hearing loss or who are hard-of-hearing, benefit from having a quiet acoustic environment - background noise including from mechanical equipment such as fans, should be minimal. Telephone equipment with volume control for individuals with hearing loss is required.

The provision of assistive listening is important for all especially when people are wearing face masks but also for a range of individuals who may have difficulty with low vocal volume or hearing difficulties thus affecting production of normal audible levels of sound.

The procurement of furniture and equipment for different types of meeting and multi-purpose rooms need to ensure that maximum flexibility and accessible options are always available.

Tables and workstations should address the knee and toes space requirements of individuals who use seated assistive mobility devices. Circulation areas also need to consider the spatial needs of larger mobility equipment including scooters.

Natural or full-spectrum coloured lighting, is a design feature that will facilitate use by all, especially for those who are blind or have vision loss for signage, controls and task lighting.

In locations where solar exposure or reflective glare may be problematic, such as where large expanses of glass are provided, providing blinds that can be louvred upwards is important.

Application

This section applies to highly-used and large meeting and multi-purpose rooms used by public and staff within a facility.

6.2.1 Design and Layout

- a. locate on an accessible path of travel;
- b. provide power door operators for entrances to large and highly used meeting or multi-purpose rooms;
- c. identify meeting / multi-purpose room(s) location with appropriate signage;
- d. ensure a consistent accessible path of travel of 1100 mm (minimum), 1800 mm preferred clear width is provided throughout space for circulation (Figure 84);
- e. provide a turning diameter of at least 1500 mm within the room;
- f. where space is available, provide a clear floor space of 2500 mm by 2500 mm;
- g. provide accessible tables and work surfaces with suitable knee clearances and seating, as identified in related sections;
- h. recommend providing movable tables and seating as they allow flexibility and accommodations to be made;
- i. provide assistive listening systems, identified with signage and International Symbol for Hearing Loss;
- j. where servery or millwork are provided, ensure clear floor space is:

Durham Accessibility and Inclusivity Requirements

April 8, 2022

6.3 Cafeteria and Dining Facilities

Rationale

Inclusive cafeteria and dining facilities are important to ensure everyone can eat together.

Cafeteria serving lines and seating area designs need to reflect the lower sight lines, reduced reach, knee-space and manoeuvring requirements of a person who is shorter or using a seated mobility assistive device such as a wheelchair or scooter. Patrons using mobility devices may not be able to hold a tray or food items while supporting themselves on canes or while manoeuvring a wheelchair. Tray slides should be designed to move trays with minimal effort.

Features such as colour and tonal contrasts and large print menus may assist for those who are blind or have vision loss and should be coordinated with customer service policies.

Providing flexible seating and tables allow easier accommodations for all users. An accessible customer service is especially important for this type of environment.

For further information, refer to the Accessibility for Ontarians with Disabilities Act (AODA), 2005 and the Integrated Accessibility Standards Regulation (Ontario Regulation 191/11).

Application

This section applies to elements unique to cafeterias and dining facilities. Typical considerations include:

- serving line and seating areas with lower sightlines, reachable surfaces and displays for users of mobility aids;
- clear aisle and floor space for overall circulation; and
- independent access.

6.3.1 Design and Layout

- a. provide a consistent accessible path of travel of least 1100 mm wide, 1800 mm preferred, throughout spaces for circulation; and
- b. where layout of cafeteria amenities are dispersed, ensure clear floor space in front of food displays and dispensing equipment of:
 - i. 915 mm wide and 1370 deep (minimum) for forward approach;
 - ii. 1525 mm wide and 915 mm deep (minimum) for side approach; and
- c. where space is available, provide clear floor space with turning diameter of 1500 mm to allow both side and frontal approach of larger wheeled mobility aids such as powered scooters and wheelchairs.

6.3.2 Food Displays and Service Lanes

Where self-service food displays are provided:

- a. ensure clear aisle width between tray slide and separating rail is 1100 mm (minimum), 1800 mm preferred (Figure 85b);
- b. provide tray slides mounted between 730 and 865 mm high above floor;
- c. provide minimum 1525 mm long tray slides;
- d. ensure at least 50% of shelves are mounted 400 to 1370 mm high for unobstructed side approach (Figure 85a); and
- e. ensure maximum side reach of 500 mm deep.

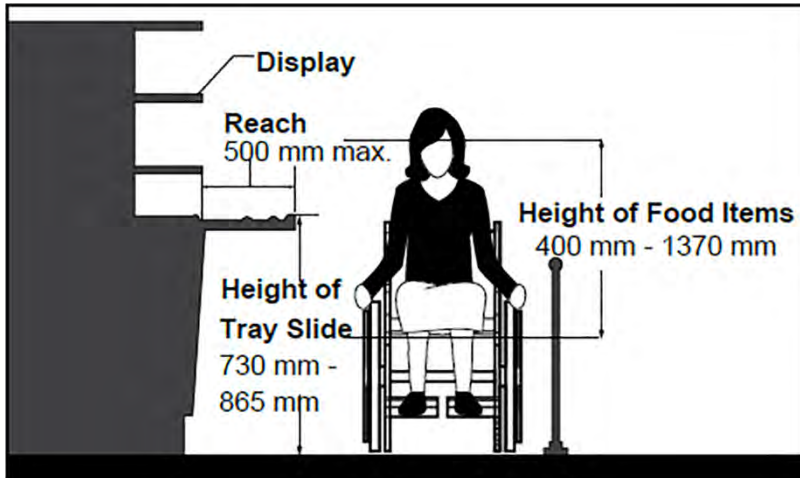

Figure 85a: Food Displays and Tray Slides - Section View

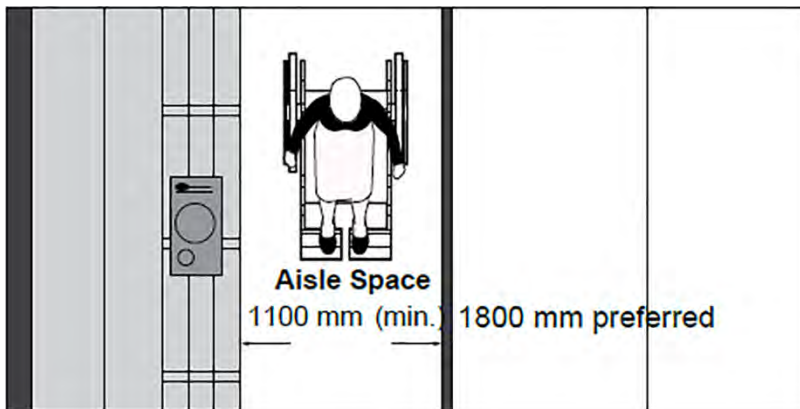

Figure 85b: Aisle Width - Plan View

6.3.3 Service and Payment Counter

- a. where provided, ensure at least one accessible service counter;
- b. provide a clear floor space for:
 - i. forward approach of 915 mm wide by 1370 mm deep; and
 - ii. side approach of 1525 mm wide by 915 mm deep; and
- c. ensure staff are visible from a seated position, to assist users if required.

6.3.4 Dining Areas

- a. ensure accessible seating spaces are provided for users of mobility aids;
- b. provide dining tables with clear knee space underneath table, as identified in relevant sections;
- c. provide a clear floor space of 1500 mm wide by 1500 mm deep (minimum) in front of dining areas; and
- d. provide informational and directional signage identifying accessible amenities with

Durham Accessibility and Inclusivity Requirements

April 8, 2022

6.4 Kitchens and Kitchenettes

Rationale

Kitchens and kitchenettes require an appropriate level of access to be useable by everyone includes those with disabilities. Adequate manoeuvring space is required for users of mobility equipment to approach and use work surfaces, storage elements and appliances. A frontal approach to work surfaces and appliances is generally safer, except at refrigerators where a side approach is usable. Where a frontal approach is used, knee and toe space are required.

For kitchen storage, ensuring the reach range of all users is important. Full-height storage cabinets or pantry cabinets are recommended as they provide a good range of accessible storage heights, which is particularly useful because in accessible kitchens, the amount of base storage is reduced by the knee clearance provisions. "Lazy Susan" trays also provide more accessible storage. Full-extension drawers and shelves provide storage space that is easy to reach and use.

The use of colour contrast between kitchen surfaces and controls will assist people with low vision locate surfaces, appliances and controls. Darker coloured work surfaces are preferable as they make it easier to identify objects located on them. Cooktops with flat ceramic surfaces should not be used for people with low vision. Colour and tonal contrasted of the front edges on the counters as well as cabinet hardware and all controls will help define the user space.

Application

This section applies to common-use kitchens and kitchenettes, for public and staff, typically available as amenities in public facilities, such as office environments and community centres, where multi purpose activity rooms are provided.

6.4.1 Design and Layout

- a. ensure floor surface is slip-resistant and has a non-glare finish
- b. ensure the following minimum clear floor space is provided directly in front of kitchen amenities and appliances, and to the one side where drawers or door open:
 - i. 915 mm wide by 1370 mm deep for forward approach;
 - ii. 1525 mm wide by 915 mm deep for side approach;
- c. where space is available, provide a turning circle of 2500 mm for users of larger mobility aids, including powered scooters and wheelchairs;
- d. ensure all controls and operating mechanisms are mounted no higher than 1100 mm from floor; and
- e. provide lighting in accordance with Section 5.7 Lighting requirements, as applicable, with task lighting option also available (e.g. under counter).

6.4.1.1 Pass-through or Galley Kitchens

For kitchens where counters, appliances or cabinets are on two opposing sides or opposite a parallel wall (Figure 86):

- a. provide a clearance of at least 1500 mm between all opposing base cabinets, countertops or walls within kitchen work areas; and
- b. ensure two doorways or openings are provided, with one at each end and with 950 mm clear width.

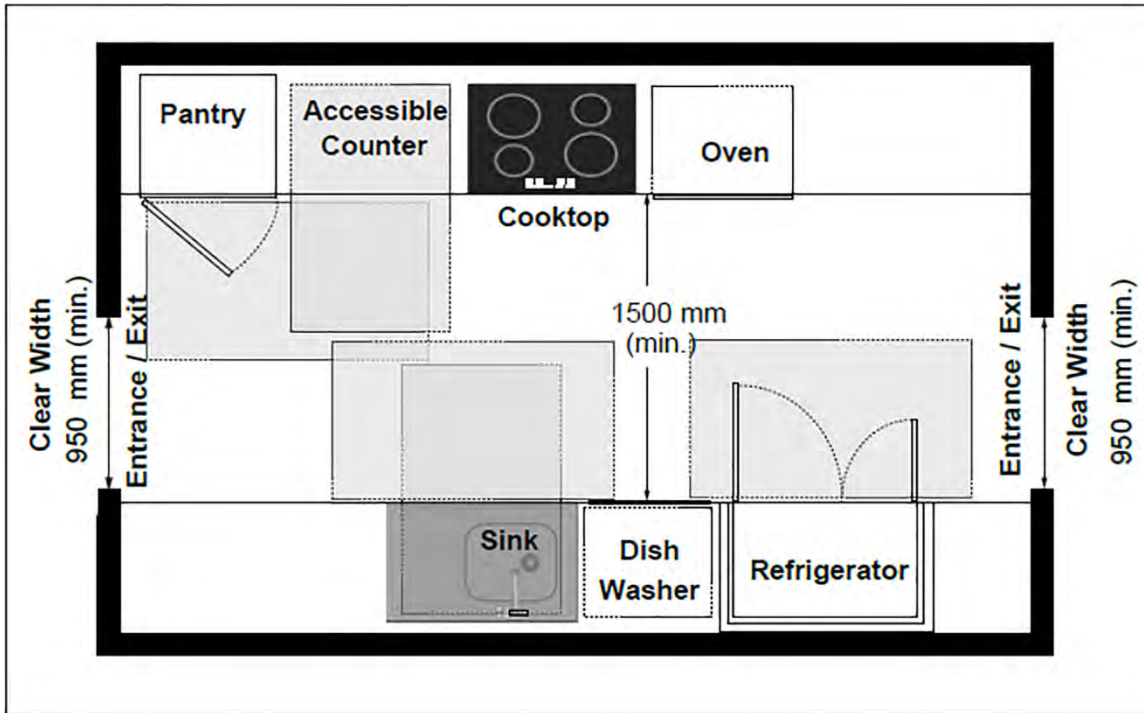

Figure 86: Pass-Through or Gallery Kitchen - Plan View

6.4.1.2 U-shaped Kitchens

Where kitchens are enclosed on three continuous sides (Figure 87):

- provide a clearance of at least 1500 mm between all opposing base cabinets, countertops or walls within kitchen work areas; and
- ensure entrance / exit clear width is at least 950 mm.

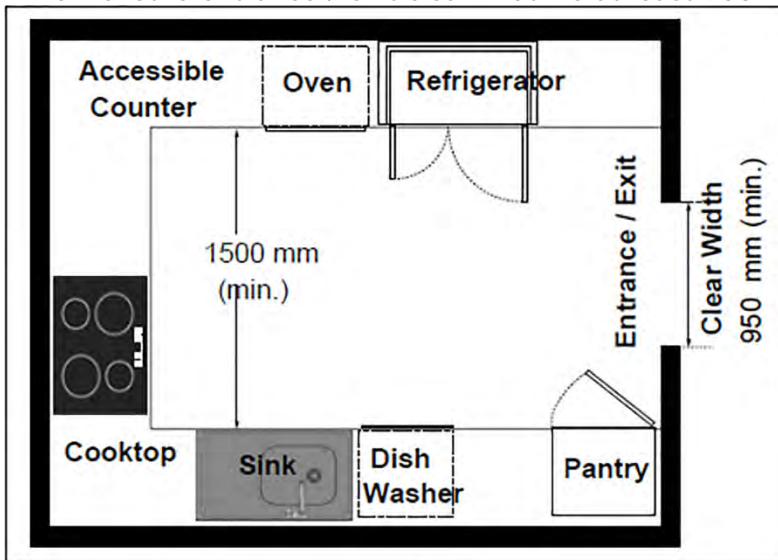

Figure 87: U-Shaped Kitchen - Plan View

6.4.1.3 L-shaped Kitchens

Where kitchens are L-shaped (Figure 88):

- provide a clearance of at least 1500 mm between all opposing base cabinets, countertops or walls within kitchen work areas.

Durham Accessibility and Inclusivity Requirements

April 8, 2022

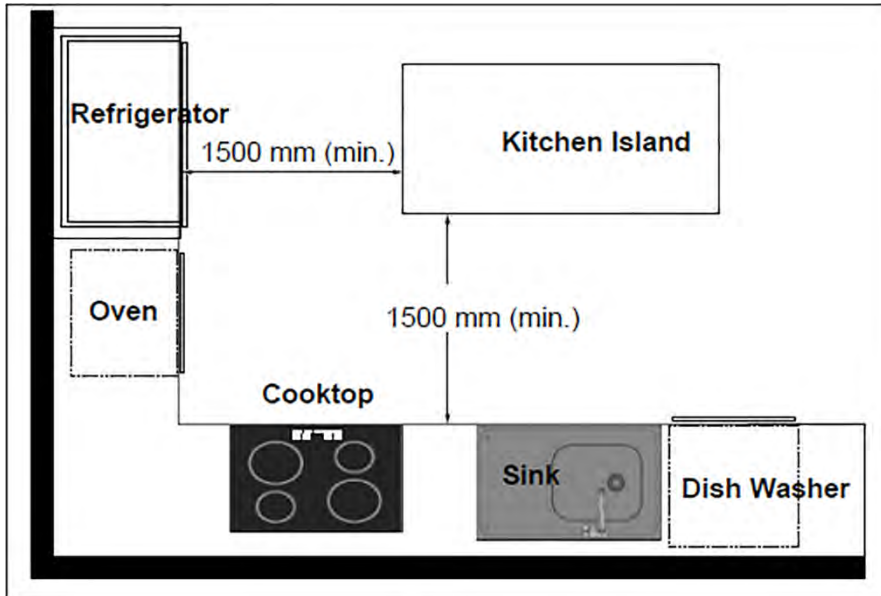

Figure 88: L-Shaped Kitchen - Plan View

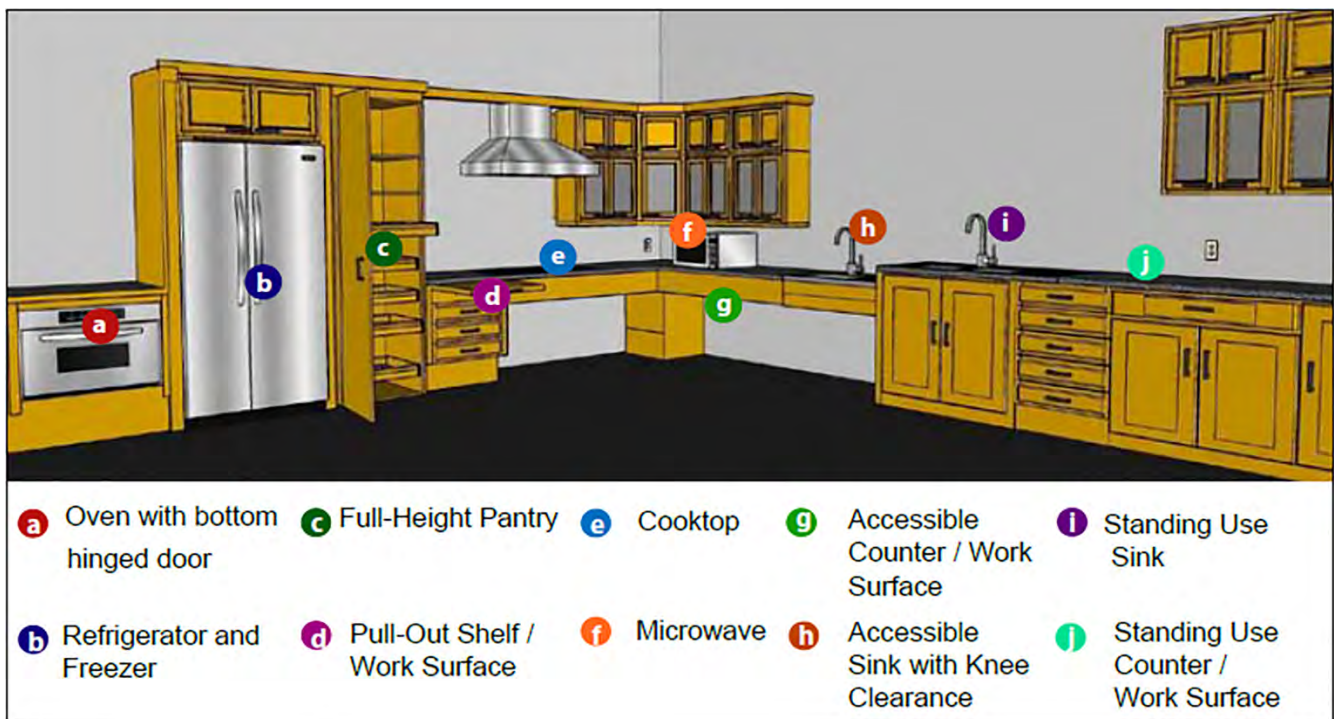

Figure 89: Example of Kitchen with Typical Amenities and Appliances

6.4.2 Counters and Work Surfaces

For accessible food preparation counters and work surfaces:

- a. provide a high tonal contrast between all cabinets, countertops, appliances and adjacent wall surfaces;
- b. ensure there are no sharp or abrasive surfaces underneath counter and work surfaces;
- c. ensure at least one (1) counter / work surface is accessible with:
 - i. dimension of 760 mm wide by 600 mm deep (minimum);
 - ii. top surface between 730 mm and 865 mm high (Figure 90);

Durham Accessibility and Inclusivity Requirements

April 8, 2022

- iii. a centred knee clearance at least 480 mm deep, 760 mm wide and 685 mm high;
 - iv. a clear floor space of at least 915 mm wide by 1370 mm, which may extend up to 480 mm underneath the counter / work surface; and
 - v. electrical outlets installed at the side or front of it.
- d. where possible, provide a portable, accessible side counter unit for frequently used appliances and related amenities;
 - e. recommend providing an additional pull out workboard below the standard counter surface;
 - f. recommend continuous countertops;
 - g. where kitchen islands are provided, recommend providing a lowered counter with knee clearance.

6.4.3 Kitchen Storage

Kitchen storage includes but is not limited to shelves, storage cabinets and drawers. Where provided:

- a. ensure at least one (1) storage unit is 1100 mm (maximum) high from floor where it is mounted above a counter / work surface;
- b. provide accessible cabinet door hardware (e.g. D-type door pull):
 - i. mount no higher than 1100 mm from floor (Figure 90);
 - ii. mount close to the bottom for upper cabinets and close to the top for base cabinets; and
- c. provide shelving above the counter and drawers or pull-out shelves below the counters;
- d. ensure toe space of 150 mm deep by 230 mm high (minimum) is provided at base cabinets, where provided (Figure 91).

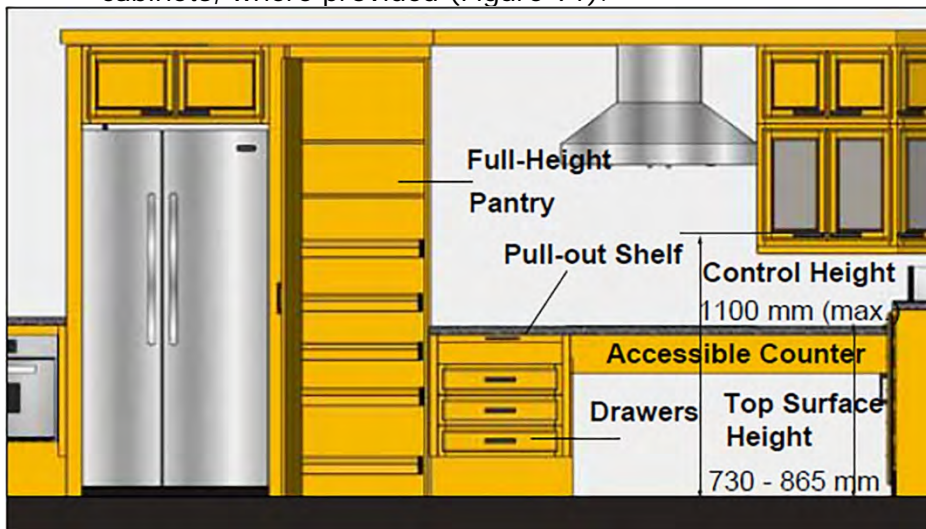

Figure 90: Kitchen Storage – Elevation View

Durham Accessibility and Inclusivity Requirements

April 8, 2022

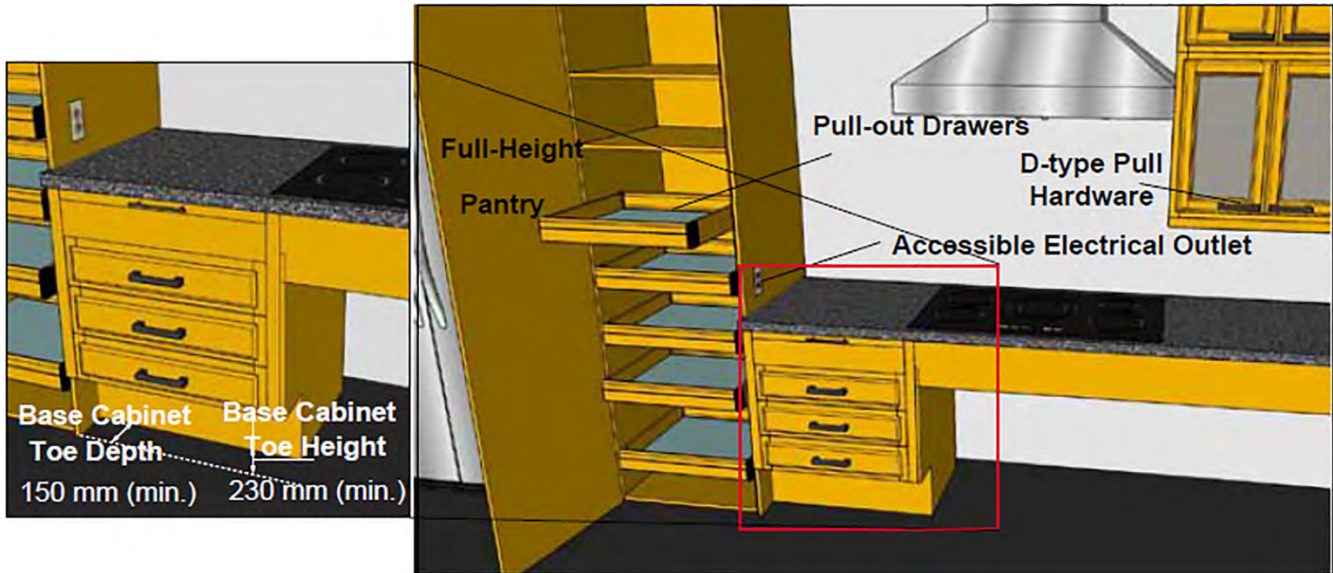

Figure 91: Kitchen Storage

6.4.4 Sinks

- install sink with its centreline at 460 mm (minimum) from a side wall;
- ensure the rim height of sink is located between 820 to 840 mm high above floor (Figure 92);
- provide knee clearance centred on the sink no less than 920 mm wide by 685 mm high by 200 mm deep;
- where toe clearance is provided, ensure it is 350 mm high by 500 mm deep (minimum);
- provide automatic faucet or lever-type controls that can be operated with one closed fist (Note: Faucets with a flexible hose attachment benefit a wider range of users.);
- ensure no sharp or abrasive surfaces under it;
- ensure hot water and drain pipes underneath sink are offset to the rear and do not obstruct the knee clearance (Figure 93); and
- where hot water and drain pipes abut the knee clearance, ensure pipes are insulated or covered to protect users.

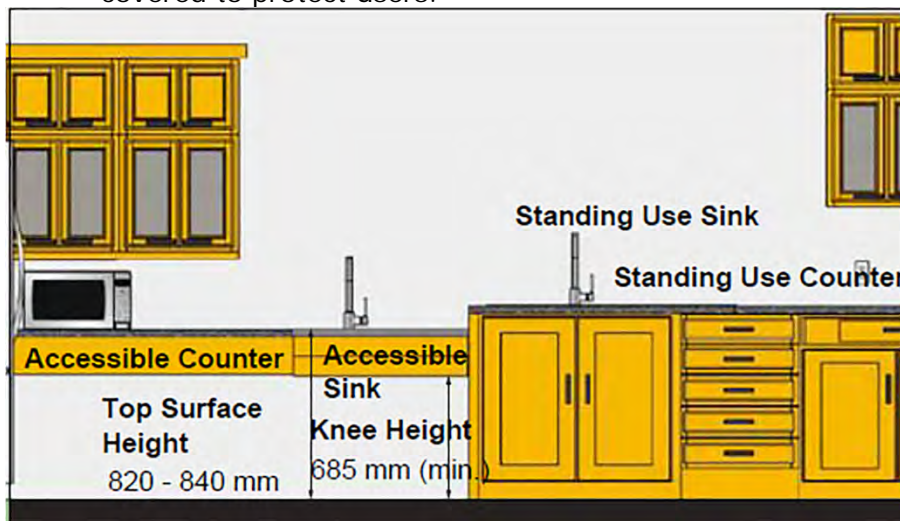

Figure 92: Sink - Elevation View

Durham Accessibility and Inclusivity Requirements

April 8, 2022

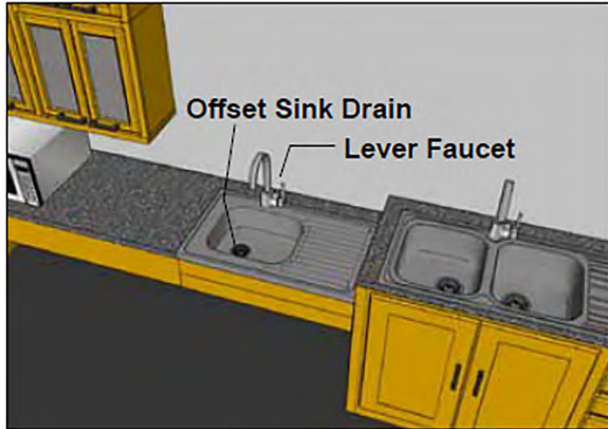

Figure 93: Accessible Sink

6.4.5 Kitchen Appliances

Kitchen appliances include but are not limited to cooktops, microwaves, ovens, refrigerators and freezers (Figure 89).

6.4.5.1 Cooktops

Where provided (Figure 94 and 95):

- a. use appliance models where controls are located away from the burners (e.g. do not require reaching across heating surface to operate);
- b. ensure a clear floor space of 915 mm wide by 1370 mm deep (minimum), which may extend up to 480 mm underneath the cooktop, is provided;
- c. ensure top surface height is located between 730 and 865 mm from the floor;
- d. provide a knee clearance centred on the cooktop of at least 760 mm wide by 685 mm high by 200 mm deep, with additional toe clearance of 500 mm deep by 350 mm high (minimum);
- e. provide insulation or other protection on the underside where knee clearance is provided; and
- f. provide a work surface on each side and at the same height as the cooktop:
 - i. width of 400 mm (minimum); and
 - ii. ensure surface is heat resistant.

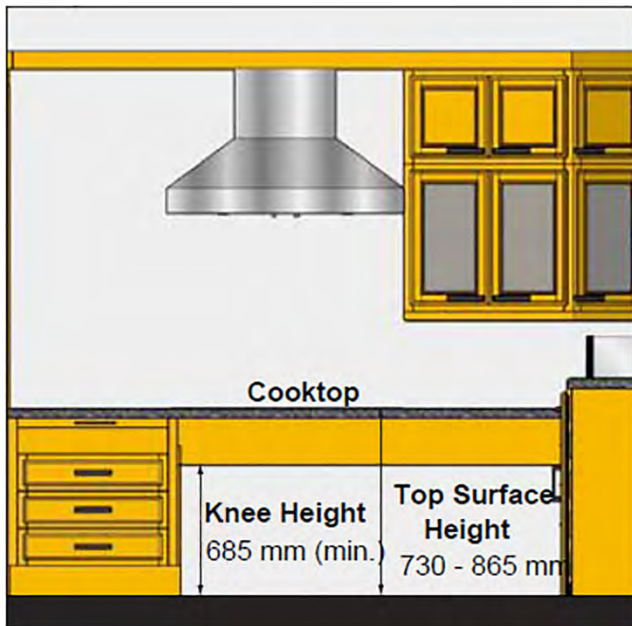

Figure 94: Cooktop - Elevation View Bb

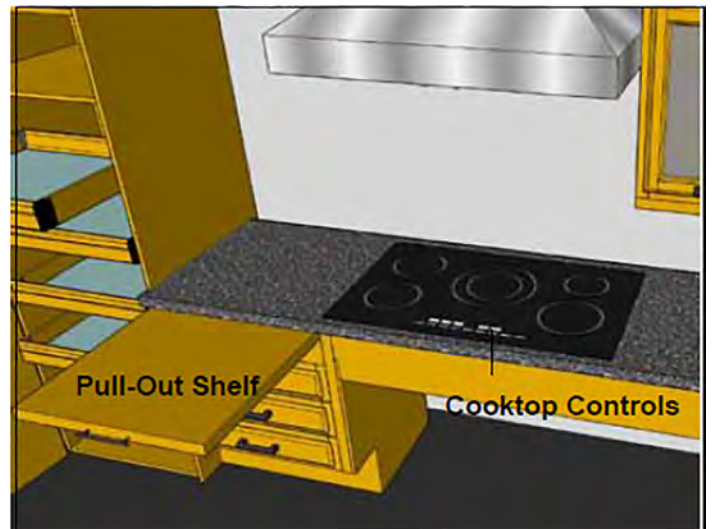

Figure 95: Cooktop

6.4.5.2 Ovens

Where provided (Figure 89):

- a. ensure oven controls are located on the front panels of oven;
- b. where microwave ovens are provided, mount at counter height;
- c. where ovens with side-hinged doors are provided:
 - i. provide heat resistant work surfaces with knee space below, adjacent to the latch side of oven door; or
 - ii. incorporate a heat resistant pull-out shelf that pulls out 250 mm (minimum) below the oven; and
- d. where ovens with bottom-hinged doors are provided, provide work surface on one side of the door.

6.4.5.3 Refrigerators and Freezers

Where provided:

- a. provide a self-defrosting freezer;
- b. provide a vertical side-by-side type refrigerator / freezer as they are more accessible;
- c. where an over- and-under type refrigerator is used, ensure the freezer shelf space is not more than 1100 mm high from the floor (Note: Models with freezers at the bottom are recommended.); and
- d. provide clear floor space in front of refrigerators / freezers, positioned or parallel approach immediately adjacent to refrigerator / freezer, with the centreline of the clear floor space offset 610 mm (maximum) from the front face (Figure 96);
- e. provide a through-the-door ice and water dispensers as it is convenient for many users; and
- f. recommend providing roll-out shelves or drawers to improve access to the refrigerator contents.

Durham Accessibility and Inclusivity Requirements

April 8, 2022

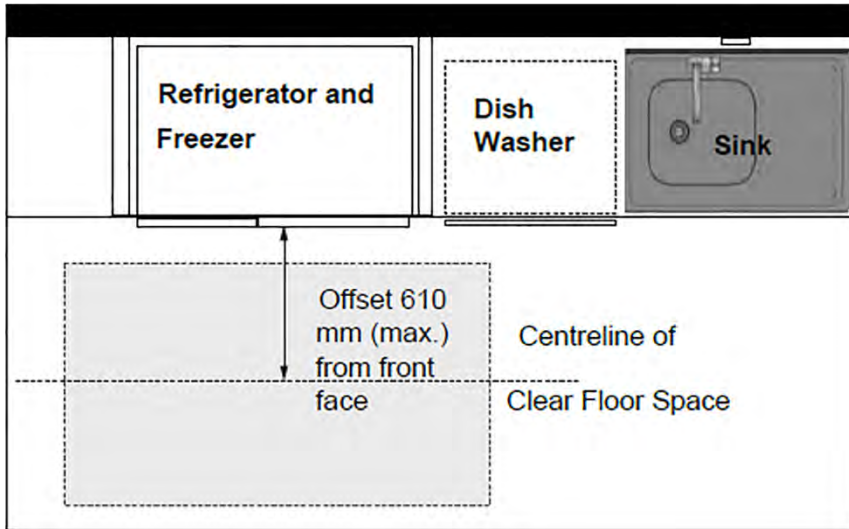

Figure 96: Clear Floor Space at Refrigerators and Freezers

Durham Accessibility and Inclusivity Requirements

April 8, 2022

6.5 Libraries

Rationale

Libraries are to be inclusive and welcoming to all.

Where traditional and automated systems are in use they will be usable for all patrons, volunteers and staff. Both the design of the facility and the provision of services should be considered. Service counters and study carrels are to accommodate the knee-space and armrest requirements of a person using mobility assistive devices. Computer catalogues, carrels and workstations will be provided at a range of heights, to accommodate people who are standing or sitting, as well as children of many ages, sizes and abilities. It is preferred to provide height-adjustable furnishings to ensure operational equality.

The provision of workstations equipped with assistive technology such as large displays, screen readers, etc. increases the accessibility of a library.

The provision of book drop-off slots at different heights for standing and seated users will enhance usability.

Application

This section applies to libraries or a designated room in a facility that is used for the same purpose.

It is recognized that libraries have unique space requirements in order to accommodate book stacks and reference materials at both high and low shelving heights. Shelving heights in collection areas with book stacks is unrestricted where staff are available to assist users when requested. Ensure staff availability is coordinated as part of a formal Accessible Customer Service policy, practice or procedure that is in place for all Library facilities.

For more information, refer to the Integrated Accessibility Standard Regulation (Ontario Regulation 191/11).

6.5.1 Design and Layout

- a. provide a consistent accessible path of travel of at least 1100 mm wide, 1800 mm preferred, throughout spaces for circulation;
- b. provide turning diameter of 1500 mm in order to allow users of mobility aids to make a 180° turn;
- c. where space is available, a clear floor space of 2500 mm is recommended to allow users of mobility aids to make a 180° turn within the aisle configuration;
- d. where provided, ensure security gates have a clear width of 950 mm (Figure 97);
- e. provide at least one accessible service counter at circulation, information or self-service checkout areas;
- f. where online catalogues or other workstations are provided, ensure at least 50% are accessible;
- g. provide lighting in accordance with Section 5.7 Lighting requirements, as applicable;
- h. ensure acoustic quality is free of unnecessary background noise;
- i. provide informational and directional signage where any services or amenities or users with disabilities are available on different floor levels (e.g. Information or Customer Service Desks);
- j. ensure library staff are provided with disability awareness / sensitivity training; and
- k. provide alternative formats for key resources based on user requests and through development of partnerships with other organizations (e.g. CNIB, Canadian Hearing Society). This includes considerations related to the availability of Audio Books on CD-ROM for users with low literacy or who have a vision loss, as well as Closed Captioning options for any audio / visual media, for users with hearing loss.

Durham Accessibility and Inclusivity Requirements

April 8, 2022

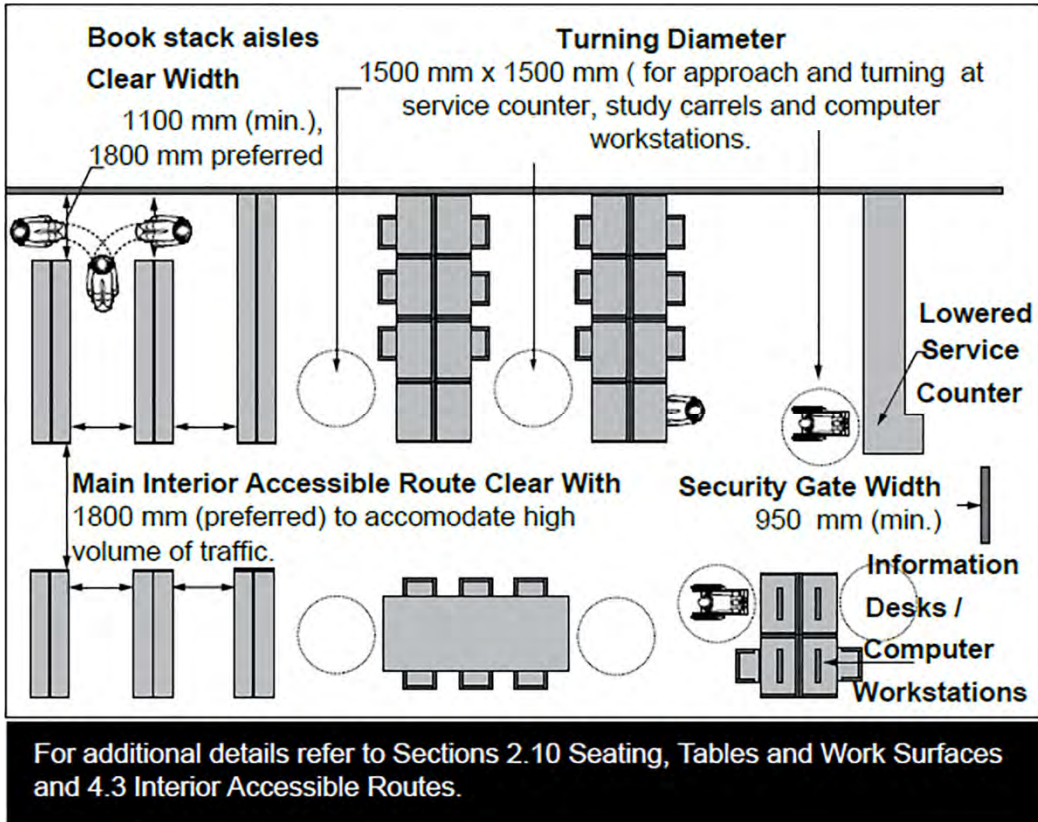

Figure 97: Library Design and Layout - Plan View

6.5.2 Book Drop Slots

- a. locate on an accessible path of travel;
- b. provide clear floor space in front of drop slot:
 - i. 915 mm wide by 1370 mm deep for a forward approach; and
 - ii. 1525 mm wide by 915 mm deep for a side approach;
- c. ensure a high tonal contrast between drop slot and mounting surface;
- d. locate slot between 900 and 1100 mm above the floor (Figure 98); and
- e. ensure slot controls are usable with closed fist and operable with one hand.

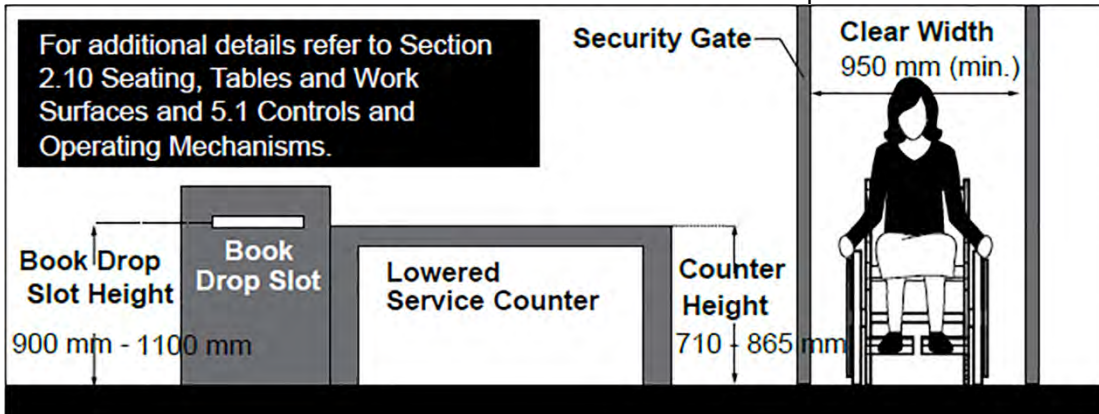

Figure 98: Library Security Gate, Service Counter and Book Drop Slot

6.5.3 Book Stacks or Carousels

- a. ensure accessible path of travel of at least 1100 mm, 1800 mm preferred between aisles (Figure 99);

Durham Accessibility and Inclusivity Requirements

April 8, 2022

- b. ensure library policy is in place to provide assistance for users to access items that are too high or too low;
- c. ensure large print collection and heavier materials are placed on lower shelves for easy access; and
- d. where more frequently used or referenced materials are provided (e.g. newspapers, periodicals, pamphlets and community brochures), a mounting height between 400 mm and 1100 mm high is required to accommodate the reach ranges of diverse users, including small children, seniors and users of mobility aids.

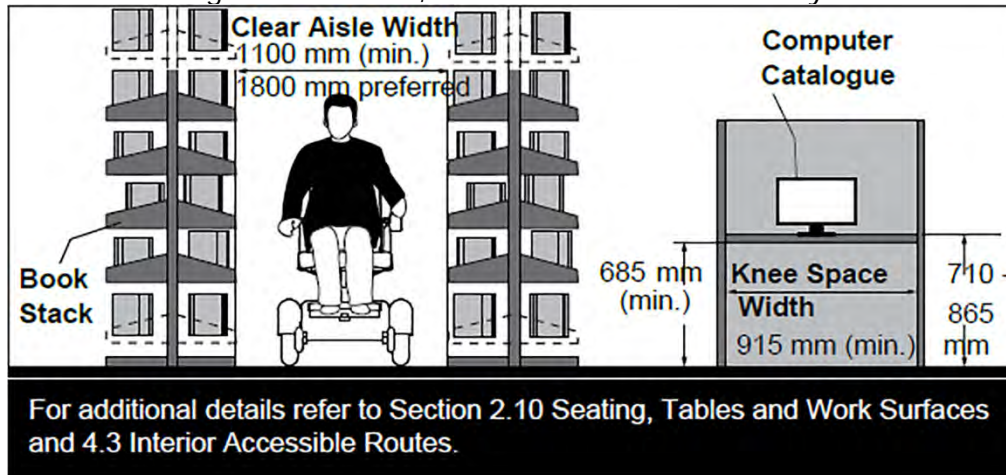

Figure 99: Book Stacks

6.5.4 Reading Lounges and Study Areas

- a. provide a variety of flexible seating options;
- b. ensure a high tonal contrast is provided between furniture and their surroundings;
- c. ensure all study tables, study carrels and work surfaces provide suitable knee and toe clearances with at least 10% of each surface type fully accessible;
- d. ensure maximum 1120 mm shelf height above study tables and carrels where applicable; and
- e. incorporate an electric outlet.

6.5.5 Computer Catalogues and Workstations

- a. provide suitable knee and toe clearances with at least 10% of each surface type fully accessible;
- b. a maximum work surface height of 865 mm;
- c. a maximum table depth of 915 mm;
- d. ensure accessible workstations have height adjustable surface and area equipped with adaptive technology (e.g. flexible mouse control and scrolling feature); and
- e. ensure at least one accessible workstation has specialized equipment for users with vision loss (e.g. screen reader software, scanner and magnifiers).

Durham Accessibility and Inclusivity Requirements

April 8, 2022

6.6 Recreational and Community Facilities

Rationale

Opportunities for recreation, leisure and active sport participation are to be available to all members of the community. Access is to be provided to halls, arenas, and other sports facilities, including but not limited to access to the site, all activity spaces, gymnasias, fitness facilities, lockers, change rooms and showers. People with disabilities will be active participants, as well as spectators, volunteers and members of staff.

For waiting areas in these facilities, the provision of benches is important for individuals who may have difficulty with standing for extended periods.

Swimming is an important recreational and therapeutic activity for many people with disabilities. The buoyancy and freedom offered by an immersive water environment can be enabling in themselves. Primary considerations for accommodating people who have mobility impairments include accessible change facilities and a means of access into the water. Ramped access into the water is preferred over lift access, as it promotes integration (everyone will use the ramp) and independence. Many people who are visually impaired will benefit from colour and textural cues along primary routes of travel and at potentially dangerous locations, such as the edge of the pool, at steps into the pool and at railings.

Application

This section applies to recreational and community facilities, whether indoor or outdoor, used by spectators, participants, volunteers, coaching staff and facility employees. Recreational and community facilities include, but are not limited to:

- courts (e.g., basketball, volleyball, tennis);
- fields (e.g. baseball, soccer, football);
- arenas (e.g., ice pad, skating rinks);
- aquatic facilities (e.g. swimming pools, spas, wading pools, splash pads, saunas);
- gymnasiums; and
- exercise and fitness facilities

Criteria in this section requires detailed review and application based on the type of facility, level of use and number of features or elements provides (e.g. total number of change rooms).

6.6.1 Design and Layout

The design and layout of recreational and community facilities, typically consists of the following elements:

6.6.1.1 Change Rooms

- a. provide at least one accessible change room, with at least one accessible change cubicle to accommodate parents with children, companions or care givers of the opposite sex.

6.6.1.2 Viewing Area

- a. provide level accessible seating spaces to accommodate users of mobility aids; and
- b. integrate assistive listening systems or visual equipment, depending on the type of venue.

6.6.2 Arenas

For access to ice pads and skating rinks in arenas:

- a. locate on an accessible path of travel;
- b. provide access panels to ice surface with clear width of at least 950 mm; and
- c. provide level or beveled access to ice pads or skating rinks.

Refer to Sledge Hockey Accessibility Design Guidelines for Arenas.

6.6.3 Exercise and Fitness Facilities

- a. ensure accessibility features are provided, if available, for at least one of each type of equipment or machine;

Durham Accessibility and Inclusivity Requirements

April 8, 2022

- b. provide a clear floor space of 915 mm by 1370 mm (minimum) for a front approach or 915 mm by 1525 mm for a side approach on one side of exercise equipment to allow transfer; and
- c. where space is available, provide a clear floor space of 1675 mm by 1675 mm for transfer to exercise equipment.

6.6.4 Aquatic Facilities

- a. ensure pool deck surfaces are firm, stable, slip-resistant and have a matte finish;
- b. ensure deck surface has running or cross-slope gradient no steeper than 1:50 (2%) for drainage of water;
- c. provide recessed drainage tiles with openings no greater than 13 mm wide;
- d. provide an accessible path of travel around the perimeter of pool deck at 1100 mm (minimum) wide, 1800 mm preferred;
- e. provide tactile walking surface indicators (TWSI) 610 mm wide to clearly delineate the perimeter of the pool deck and locate where any area contiguous to the pool deck may be confused with the deck;
- f. provide high tonal contrast on pool lane markers, related tie-off devices, starter blocks and any other permanent or temporary equipment (e.g. life-guard chairs, diving boards or platforms, safety equipment); and
- g. provide an area for mobility aids or assistive devices to be stored so they do not obstruct circulation around pool deck.

6.6.4.1 Entry and Exit Point

Provide at least one accessible entry and exit point:

- a. ensure entry and exit point is located away from any designated swimming lanes.

6.6.4.2 Sloped Entry or Ramp

For new construction, ensure sloped entry or ramp is provided. Transfer lifts are permitted as an option for existing facilities that cannot be retrofitted to provide a sloped entry or ramp.

- a. ensure running slope is no more than 1:15 (6.67%);
- b. where possible, provide running slope of no more than 1:20 (5%);
- c. provide handrails, mounted between 865 mm and 920 mm high from surface, extending at top landing only (Figure 100) (Note: Extensions are not required on bottom landing as they can be a bumping hazard for swimmers.);
- d. ensure the clear width between handrails is 1100 mm (minimum);
- e. provide top and bottom landing of at least 1670 mm by 1670 mm;
- f. ensure water depth at the bottom of the ramp is at least 600 mm and not greater than 900 mm;
- g. provide a hard-surfaced area capable of accommodating a movable barrier separating the area from the deck, and is 750 mm (minimum) wide that is contiguous to the entire length of the part of the submerged ramp that pierces any part of the deck; and
- h. ensure the finishes in the submerged portions of the ramps and curbs are different in colour or shade from each other and from that of the pool walls and bottom.

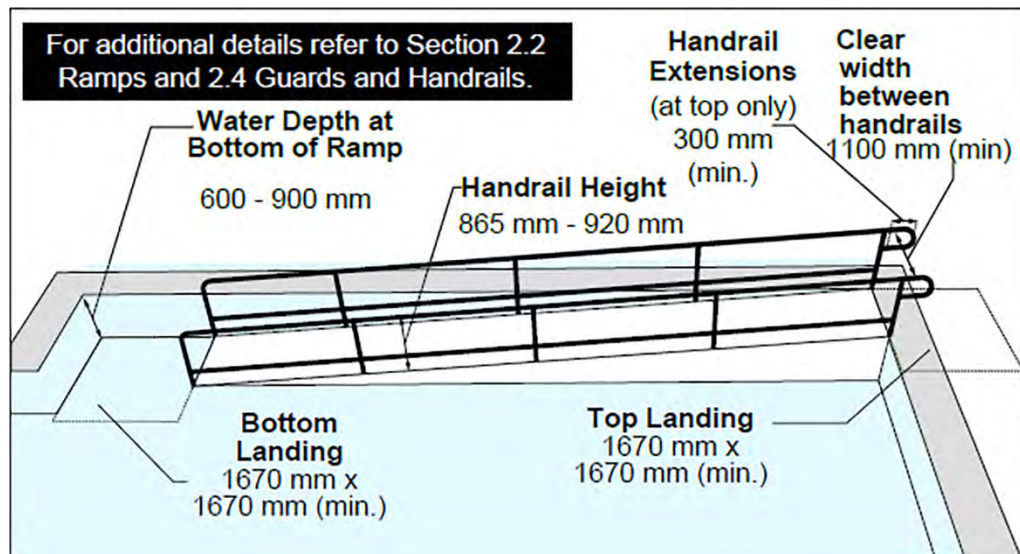

Figure 100: Sloped Entry or Ramp to Swimming Pool

6.6.4.3 Transfer Systems

Existing facilities without ramps are encouraged to secure a fixed transfer lift to support client needs.

6.6.4.4 Transfer Lifts

- locate transfer lifts on an accessible path of travel and in shallow end, where water level does not exceed 1200 mm high;
- ensure the centreline of the seat for the transfer lift is located over the deck and at 400 mm (minimum) from the edge of the pool when in the raised position;
- ensure seat is firm with suitable padding, with a minimum width of 400 mm;
- provide a clear deck space of 1675 mm by 1675 mm on the transfer side of the lift;
- ensure lift is designed to be operable without assistance from both the deck and water and when in use, its controls and operating mechanism are unobstructed and mounted no higher than 1100 mm from pool deck or water surface; and
- ensure single user lifts have a minimum weight capacity of 135 kg and capable of sustaining a static load of at least 1.5 times the rated load.

Durham Accessibility and Inclusivity Requirements

April 8, 2022

6.7 Change Rooms

Rationale

In addition to accessible common use change rooms, a separate accessible unisex change room is important. This is valuable in a scenario where an attendant of the opposite sex or a parent or spouse is assisting a disabled child or adult. Sufficient space should be allowed for two people and an assistive mobility device, along with accessible benches and accessories.

The provision of accessible handrails along circulation routes from dressing rooms to facilities including the pool, gymnasium and other activity areas, will benefit many facility users.

The provision and number of Universal Change Rooms or Stalls as part of Change Rooms and related areas may vary depending upon the type of facility.

Application

This section applies to change rooms, which may also be referred to as dressing / locker rooms or fitting areas, used by the public or staff. These spaces share common elements and design features. Typically, change rooms are provided in arenas, pools, fitness centres and related recreation / community centres.

For a Pool facility, often a combination of shared and private spaces are provided for change areas, which often also integrate washroom and shower facilities as part of the overall design. The total number of universal change rooms or stalls should be identified based on the size and occupancy of each facility and the required fixture counts for washrooms and showers.

6.7.1 Provision and Location

For Universal Change Rooms or Stalls that are intended for private use in addition to other public or staff change rooms that may be available:

- a. provide at least one universal change room or stall for each type of other regular change room facility that is provided (e.g. Male, Female or Universal Change Room);
- b. in a retrofit situation, 10% of change rooms, and never less than one, should be universal, for each type of other regular change room facility that is provided; and
- c. ensure universal change rooms or stalls are located along an accessible route.

6.7.2 Design and Layout

- a. where doors are provided at the change room entrance, provide a clear width of 950 mm (minimum) and equip with power door operators;
- b. provide a consistent accessible path of travel 1100 mm (minimum) wide, 1800 mm preferred throughout spaces for circulation in the change room;
- c. ensure a clear turning diameter of 1500 mm (minimum) is provided inside change room circulation area to allow users of mobility aids to make a 180 degree turn;
- d. ensure the floor surface is slip-resistant and allows suitable drainage;
- e. where washroom facilities are provided as part of a change room, provide accessibility design requirements, in accordance with Section 4.5 Washrooms requirements, as applicable;
- f. where shower facilities are provided as part of a change room, provide accessibility design requirements, in accordance with Section 4.6 Showers requirements, as applicable; and
- g. provide lighting in accordance with Section 5.7 Lighting requirements, as applicable.

6.7.3 Change Room Amenities

Change room amenities typically include, but are not limited to, benches, lockers, showers and washrooms.

6.7.3.1 Permanent Benches

Where permanent benches are provided:

Durham Accessibility and Inclusivity Requirements

April 8, 2022

- a. provide seat height of 450 to 500 mm above finished floor to allow users of mobility aids to transfer;
- b. ensure seat depth between 330 mm to 510 mm, with back support, unless seat surface is permanently positioned against a wall; and
- c. provide high tonal contrast finishes to assist with distinguishing bench surfaces from surroundings.

6.7.3.2 Lockers

- a. Where lockers are provided inside change rooms:
- b. ensure at least 10% of the total number of lockers but never less than one is designated as accessible;
- c. identify accessible lockers clearly with signage (e.g. International Symbol of Accessibility);
- d. provide a clear floor space in front of accessible lockers of:
 - i. 915 mm wide at 1370 mm deep (minimum) to allow for a forward approach; and
 - ii. 1525 mm wide by 915 mm deep (minimum) to allow a side approach;
- e. mount bottom shelf between 400 mm and 1200 mm high from the floor;
- f. ensure locking mechanism is mounted between 900 mm and 1100 mm high above floor; and
- g. ensure identification / number signage for all lockers:
 - i. is mounted no higher than 1500 mm (centre);
 - ii. provides lettering or number print size between 13 mm and 19 mm high, with either raised or recessed lettering; and
 - iii. provides a high tonal contrast with the background.

6.7.4 Universal Change Rooms or Stalls

- a. identify clearly with signage (e.g. International Symbol of Accessibility);
- b. provide a clear turning diameter of 1700 mm (minimum) inside of the change room or stall (Figure 101a);
- c. where space is available; provide a 2500 mm turning diameter inside universal change rooms or stalls;
- d. ensure floor surface is firm, level and slip-resistant;
- e. provide an entrance door or stall door with:
 - i. a clear width of 950 mm (minimum), when door is in an open position;
 - ii. a locking mechanism that can be locked from the inside and released from the outside, in case of emergency;
 - iii. spring hinges or gravity hinges in the case of a stall door, so that door closes automatically, where the door swings outwards; and
 - iv. a power door operator, where an entrance door is required for a private universal change room;
- f. provide a change bench 1830 mm long by 760 mm wide, mounted with top surface between 450 and 500 mm high;
- g. provide grab bars with specifications identified in Section 4.5.7 Grab Bars:
 - i. install one L-shaped grab bar at the end of the bench, with the vertical component, 150 mm (minimum) from front edge of seat and clearance of 150 mm (minimum) above the bench seat (Figure 101b);
 - ii. install one horizontal grab bar, 1200 mm (minimum) long, mounted 750 to 850 mm high and centered on the long side of the bench;
- h. provide minimum of two collapsible coat hooks protruding maximum 50 mm, and mounted maximum 1200 mm high;
- i. provide motion sensor or automatic illumination of the interior, and lighting in accordance with Section 5.7 Lighting requirements, as applicable; and
- j. include a full-length mirror.

Durham Accessibility and Inclusivity Requirements

April 8, 2022

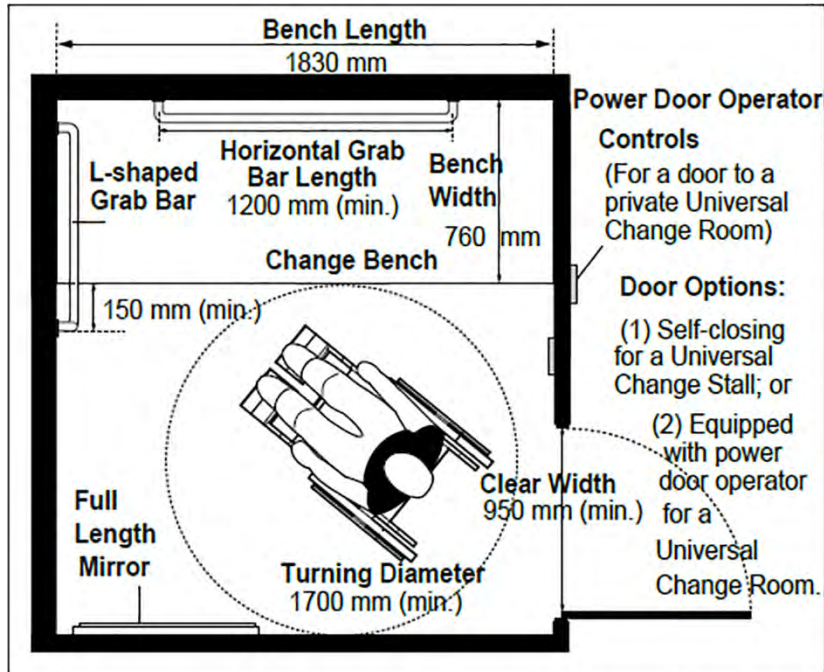

Figure 101a: Universal Change Room or Stall - Plan View

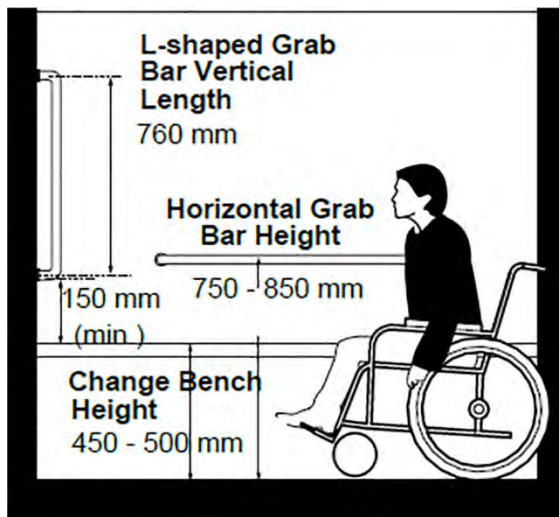

Figure 101b: Grab Bar Dimensions

Durham Accessibility and Inclusivity Requirements

April 8, 2022

6.8 Balconies and Terraces

Rationale

Inclusive balconies and terraces are important to full accessibility of a facility. Where a number of outdoor balconies, porches, patios or terraces are provided, it is desirable to consider options for protection from weather including different levels of sun and wind protection. This is of benefit to individuals with varying tolerances for sun or heat. Entry doors to these spaces should be designed to match all entry door requirements. Doors to these spaces also typically incorporate large expanses of glazing. These need to be appropriately marked to increase their visibility so they do not become a hazard. Thresholds at balcony doors should be avoided.

Application

This section addresses spaces that may be used as exits and areas of refuge from public facilities, such as common-use balconies and terraces.

This section does not address balconies and terraces within private residences.

6.8.1 Design and Layout

- a. locate on an accessible path of travel;
- b. ensure ground or floor surfaces are firm, slip-resistant with maximum gradient of 1:50 (2%) to permit drainage;
- c. where spacers for drainage are provided on ground surfaces, ensure maximum width of 6 mm between each;
- d. provide depth of 2000 mm (minimum) (Figure 102);
- e. provide minimum 1100 mm clearance between edge of outswinging door and guard/railing;
- f. ensure threshold is beveled at slope of 1:2 (50%) (maximum), where transition is between 6 to 13 mm; ensure door stops and door sweeps do not prevent maneuverability;
- g. where doors open directly into a path of travel, provide cane detectable guards or other protective barriers located perpendicular to the door; and
- h. where guards are provided, design to facilitate visibility from seated position (Note: Guards at balconies and terraces may consist of vertical pickets or glass).

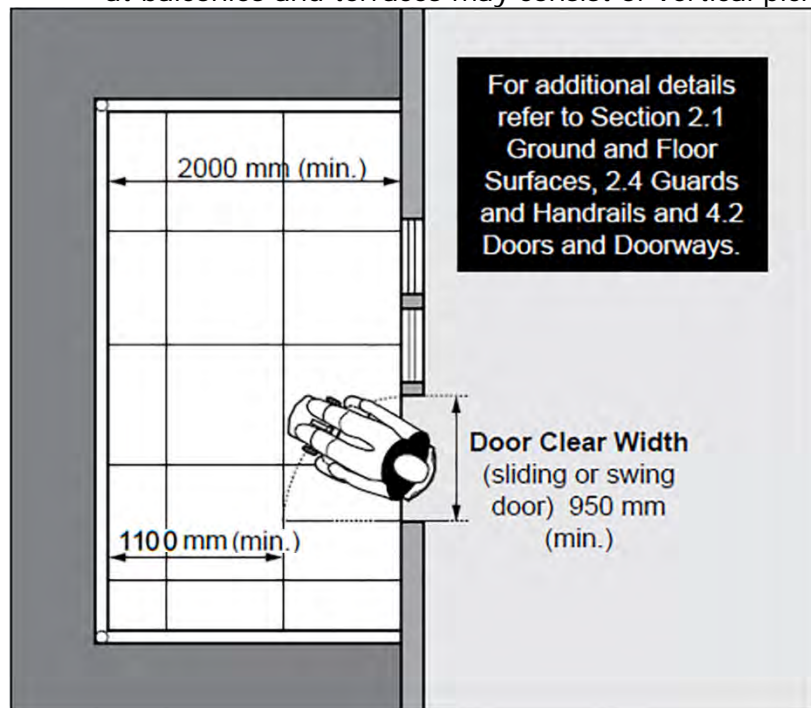

Figure 102: Balcony/Terrace - Plan View

Durham Accessibility and Inclusivity Requirements

April 8, 2022

6.9 Service Counters

Rationale

Service counters should be accessible and welcoming to all visitors including those with a wide range of disabilities. A choice of counter heights is recommended to provide a range of options for a variety of people. Lowered sections will serve children, people of short stature and people who use mobility devices such as a wheelchair or scooter. The choice of heights should also extend to speaking ports and writing surfaces.

The provision of knee space under the counter facilitates face to face communication and use by a person using a seated mobility assistive device such as a wheelchair or a scooter.

The provision of assistive listening devices, especially where glass or plexiglass barriers separate the service provider from the public, is important for both public and staff for the range of individuals who may have difficulty with low vocal volume thus affecting production of normal audible levels of sound.

The use of colour contrast, acoustic controls, tactile difference or audio landmarks (e.g., receptionist voice or music source) can assist those who are blind or have vision loss to more precisely locate service counters or speaking ports.

Application

This section applies to service counters used by both the public and staff, whether the services are obtained in the buildings or outdoors.

A variety of service counter applications are provided in the built environment, with numerous options for accessible design. Service counters may include, but are not limited to:

- reception desks;
- check-out counters;
- teller counters;
- security counters;
- information desks or kiosks; and
- food service counters.

6.9.1 Provision

- a. where a single queuing line serves a single or multiple counters, ensure each service counter is accessible; or
- b. where there are multiple queuing lines and service counters, ensure at least one (1) service counter is accessible for each type of service provided.

6.9.2 Design and Layout

- a. locate on an accessible path of travel;
- b. where there are multiple queuing lines and service counters, provide signage (e.g. International Symbol of Accessibility) to identify the accessible service counter(s);
- c. provide clear floor space in front of service counters for users of mobility aids (Figure 105):
 - i. 915 mm wide by 1370 mm deep to allow forward approach; and
 - ii. 1525 mm wide by 915 mm deep to allow side approach;
- d. ensure service counter surface provides a high tonal contrast compared with adjacent surfaces to identify counter when approaching;
- e. ensure accessible service counters are not used as storage space;
- f. provide lighting in accordance with Section 5.7 Lighting requirements, as applicable;
- g. ensure sources of light (natural or artificial) are not positioned directly behind service counters as they place people in silhouettes, which is a problem for people who lip read and people with vision loss; and
- h. provide a lowered counter usable from seated position
 - i. with top surface mounted between 710 mm and 865 mm high above floor;

Durham Accessibility and Inclusivity Requirements

April 8, 2022

- ii. ensure a clear knee space under the counter of at least 480 mm deep by 915 mm wide by 685 mm high (Figure 104); and
- iii. ensure maximum forward reach of 635 mm deep across top.
- i. Where service counters are accessible on both sides for public and staff use, it is preferred that the width of counter surface should allow seating positions to be diagonal from each other to allow suitable reach across counter for transactions.



Figure 103: Example of Typical Service Counter

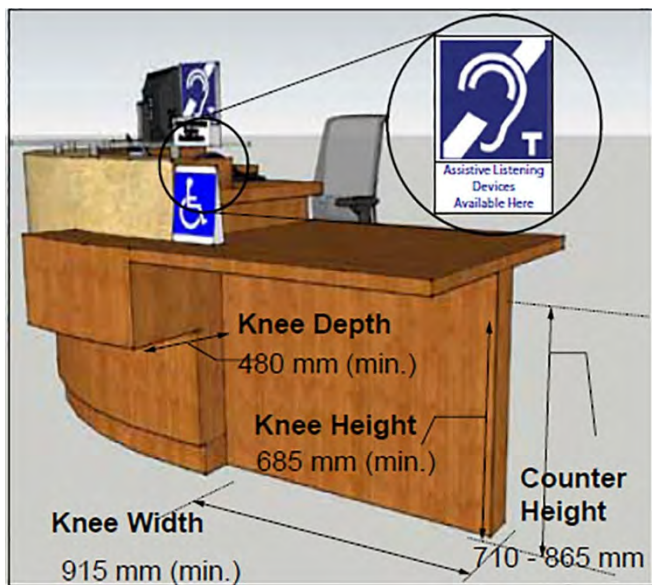

Figure 104: Dimensions of Accessible Service Counter

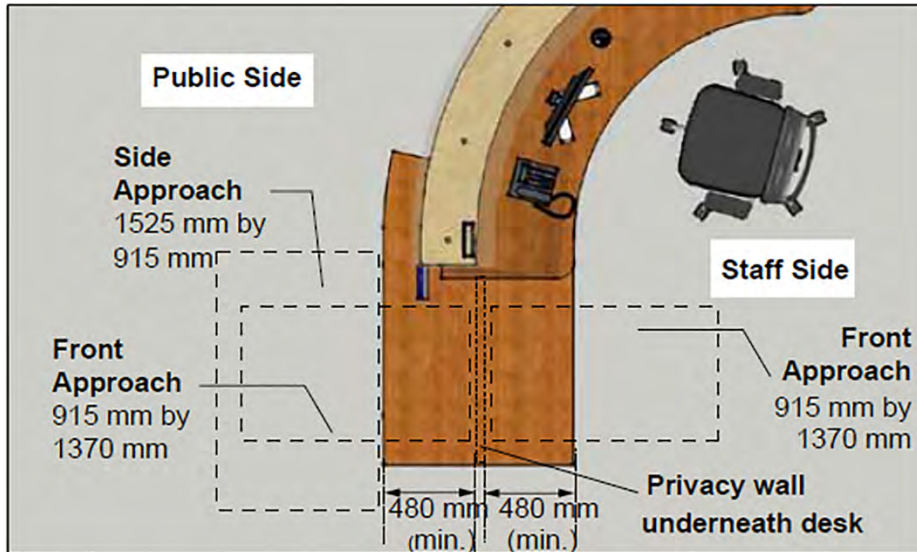

Figure 105: Clear Floor Space Requirement at Accessible Service Counter - Plan View

6.9.3 Communication Systems

Where communication systems are provided at service counters:

- a. ensure counter areas are well-lit to assist staff and visitors with hearing loss who may communicate by lip reading;
- b. where speaking ports are provided, provide at least one speaking port at 1100 mm high (maximum) from floor level;
- c. where no staff person is available, provide an information phone or call bell with information signage, with controls mounted at 1100 mm (maximum);
- d. integrate alternate devices for visitors who are Deaf, deafened or hard of hearing;
- e. where assistive listening systems are available, ensure signage with International Symbol for Hearing Loss is provided to indicate devices are available for use;
- f. where staff communicate from an enclosed counter behind glass, ensure the glazing does not reflect glare. Where appropriate install sliding windows that open fully to allow communication, whether verbal, through lip reading or use of sign language; and
- g. provide disability awareness / sensitivity training for staff where communication systems are provided to ensure proper use and interaction with customers with disabilities.

Durham Accessibility and Inclusivity Requirements

April 8, 2022

6.10 Waiting and Queuing Areas

Rationale

Queuing areas for information, tickets or services should permit people who use wheelchairs, scooters and other mobility devices as well as people with a varying range of user ability to move through the line safely and independently without stigmatization or segregation.

Waiting and queuing areas need to provide space for mobility devices, such as wheelchairs and scooters. Queuing lines that turn corners or double back on themselves will need to provide adequate space to manoeuvre mobility devices. Providing handrails in queuing lines may be useful support for individuals and guidance for those who are blind or have vision loss. The provision of benches in waiting areas is important for individuals who may have difficulty with standing for extended periods.

Application

This section applies to waiting and queuing areas in both interior and exterior environments.

6.10.1 Waiting Areas

Where waiting areas are provided:

- a. position the waiting area so that it is clearly visible when entering the facility;
- b. provide directional and informational signage to identify and guide users to waiting areas, where they may not be clearly visible when entering a facility;
- c. provide tactile floor plan / directional map to assist users with vision loss with wayfinding throughout complex facilities;
- d. ensure a lowered counter with suitable knee clearance for users of mobility aids is provided, where there is a counter;
- e. where fixed seating is provided, ensure at least 3% of the seating is accessible but in no case fewer than one accessible seating space;
- f. where accessible seating is provided:
 - i. provide a clear floor space of 915 mm wide and 1370 mm depth, adjacent to fixed seating / waiting area and away from the main path of travel, for users of mobility aids to position themselves, their equipment, a service animal, or maneuver throughout the space (Figure 106) (Note: Clear floor space for designated accessible seating must be positioned to allow shoulder alignment for user of mobility aid and person in adjacent seat.);
 - ii. locate adjacent and connected to an accessible path of travel;
 - iii. provide variety of seating options, including back and arm supports for various users; and
 - iv. ensure accessible seating is integrated with the overall layout of other seating that is provided in waiting areas;
- g. provide companion seating immediately adjacent to the accessible seating;
- h. provide a range of seating options such as wider seats;
- i. provide a building directory for large facilities, especially where no rooms are assigned; and
- j. where lower coffee or telephone tables are provided adjacent to seating waiting areas, ensure the top surface is 510 mm high (minimum), for reach from a seated position.

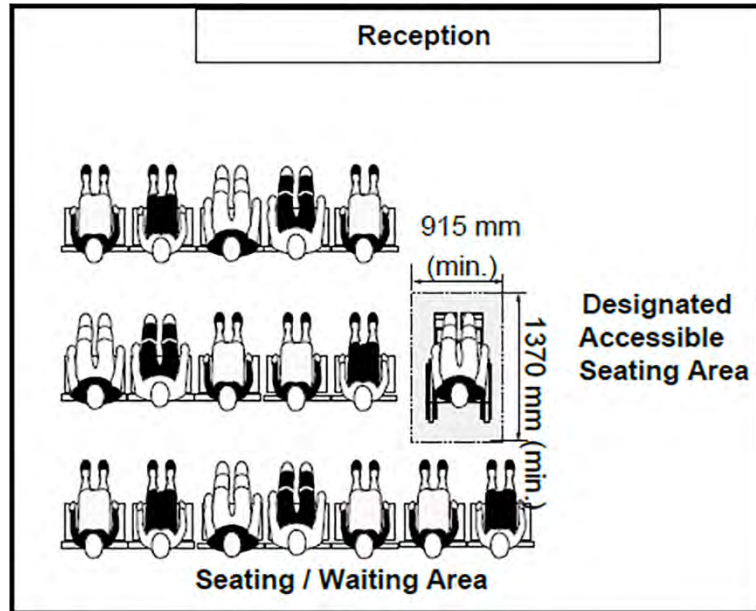

Figure 106: Waiting Area - Plan View

6.10.2 Queuing Areas

Where queuing areas are provided:

- a. locate on an accessible path of travel; and
- b. provide directional and informational signage to identify location of queuing area entry.

6.10.2.1 Fixed Queuing Guides

When providing fixed queuing guides:

- a. ensure clear width of 1100 mm (minimum) between guides (Figure 107);
- b. provide clear floor space of 1675 mm wide by 1675 mm deep (minimum), where queuing guides change direction and where they begin and end;
- c. where space is available, provide clear floor space of 2440 mm by 2440 mm at entry, exit and turn locations to accommodate larger wheelchairs and scooters;
- d. ensure lower edge or base guides are cane-detectable, mounted at or below 680 mm from floor, with supports (Note: Rope or flexible banding is not recommended for permanent queuing systems because they are more difficult to detect with a long cane and are unstable.);
- e. where temporary queuing guides are provided, ensure they are cane detectable and stable;
- f. provide a high tonal contrast between guide surfaces and adjacent surroundings (e.g. for enhanced visibility);
- g. ensure guides have a glare-free finish;
- h. define and identify permanent queuing areas with use of floor patterns, colours, and/or textures
- i. where queues are longer than 10 meters, recommend providing rest areas with accessible seating along the queuing system; and
- j. provide a rest area at the end of the queuing system for people to wait for companions who are queuing.

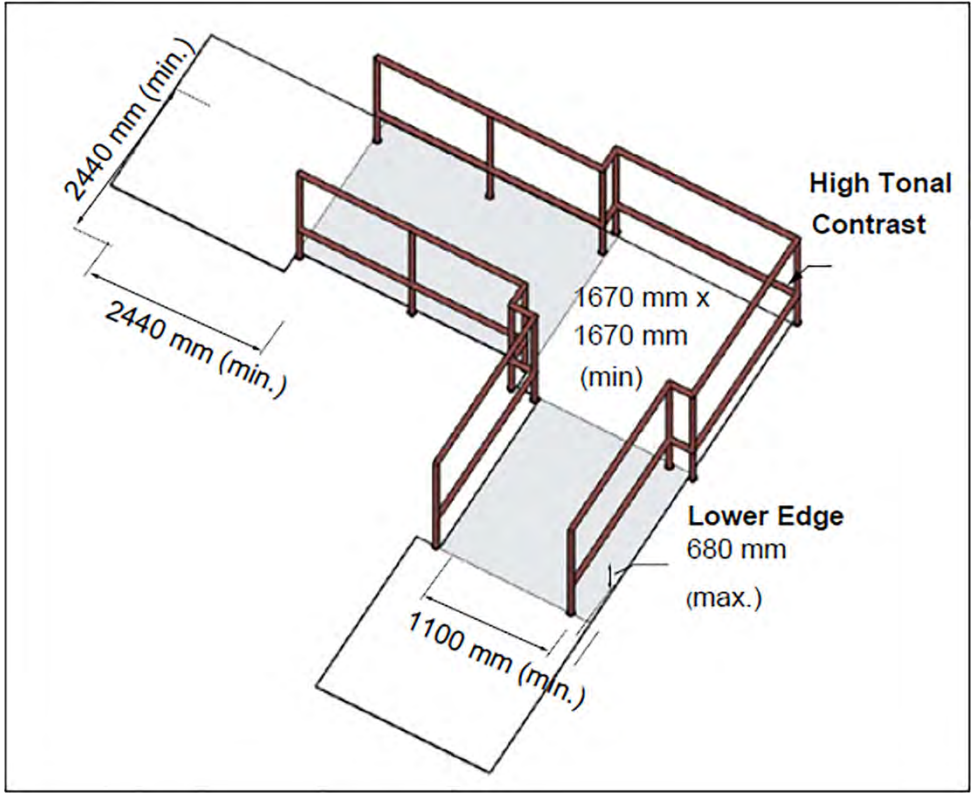

Figure 107: Fixed Queuing Guide

Durham Accessibility and Inclusivity Requirements

April 8, 2022

6.11 Visitability – Housing

Rationale

Visitable housing ensures living spaces are places where people with disabilities can also come for a coffee, a meal or a short visit. Social engagement is associated with a stronger immune systems and better mental health as interacting with others boosts feelings of well-being and decreases feelings of depression.

Visitability refers to a design strategy that aims to provide basic access to a home through at least three key design elements:

1. Level entry and clear space at entrance area;
2. Wider doors and accessible routes throughout the entrance level; and
3. A washroom on the same level as the accessible entrance.

Visitability does not refer to the creation of barrier-free / fully accessible units, but rather, it provides considerations for basic access and adaptability. Through the use of minimal adjustments, visitable housing makes communities more livable for people with physical disabilities, those who use mobility aids, and seniors by providing options to age in place.

Application

For the private sector, visitability is encouraged for the construction and / or substantial renovation of residential housing units.

This section does not apply to ongoing maintenance and repair to existing public, social or affordable housing.

6.11.1 Design Requirements

Key design features for visitable housing are summarized as follows:

6.11.1.1 Exterior Path of Travel

- a. ensure minimum clear width of 1800 mm wide; and
- b. provide a gentle grade (maximum 1:20 or 5%) from the street, sidewalk, back lane, or the dwelling unit's parking space leading to an accessible entrance into the dwelling unit.

6.11.1.2 Entrance and Landing Area

- a. provide a minimum clear area of 1525 mm by 1525 mm at entrance landing;
- b. ensure there is no step or elevation change at entrance;
- c. provide a no or low-profile threshold at entrance; and
- d. ensure that the entry into a visitable unit is through the main entrance to the unit. Where this is not possible, an alternative entrance may be used, including an entrance located at the side, rear or through the garage of the home.

6.11.1.3 Interior Circulation

- a. provide doorways with a clear width of 950 mm (minimum); and
- b. ensure clear passage is provided throughout main floor corridors (on the same level as main entrance), with no elevation changes, with a minimum clear width of 950 mm (1200 mm is preferred) allowing access to all main floor activity areas, including the washroom.

6.11.1.4 Washroom

Ensure a washroom is located on the main or ground floor level with the following features:

- a. contain a minimum of one sink and one toilet;
- b. entrance door swings outward or is sliding;
- c. ensure clear floor space of 760 mm by 1220 mm is provided, clear of any door swing; and
- d. provide a clear route to the toilet 950 mm wide (minimum).

6.11.2 Recommended Visitability Features

- a. Doorways with a clear width of 950 mm.
- b. For doors at entrance and throughout main floor level, hardware such as handles, pulls, latches and locks that are operable with one hand and mounted no higher than 900 mm

Durham Accessibility and Inclusivity Requirements

April 8, 2022

- from finished floor. Operation of door hardware should not require fine manual dexterity, such as grasping, pinching or twisting. Return lever-type door opening hardware is recommended.
- c. At main entrance, provide electrical rough-in on the hinge side for the option of installing a power door operator in the future.
 - d. Latch-side clearance of 600 mm on the pull side and 300 mm on the push side at entrance and interior doors.
 - e. Doorbell / intercom system operating controls mounted at 1100 mm.
 - f. Raised electrical outlets mounted at 400 mm (minimum) to centre line above finished floor level.
 - g. For the main floor washroom:
 - i. provide a minimum of one suitably mounted grab bar and wall reinforcement for future grab bar installation; and
 - ii. provide lever type faucet controls and non-slip flooring; and
 - h. For the kitchen:
 - i. provide lever type control at sink;
 - ii. provide clear floor space directly in front of each appliance, sink and work counters and to the one side where drawers and doors open: 915 mm wide by 1370 mm deep for forward approach and 1525 mm wide by 915 mm deep for side approach; and
 - iii. provide a minimum clearance between counters and all opposing cabinets of 1500 mm (minimum).

Durham Accessibility and Inclusivity Requirements

April 8, 2022

6.12 Outdoor Public Use Eating Areas

Rationale

Inclusive outdoor public use eating areas ensure that everyone can enjoy a meal outside.

Outdoor dining tables with an extension of the table surface make them accessible to a person using a wheelchair.

A firm, level surface around the table, with an accessible path leading to the table, is required for wheelchair and scooter accessibility but also for anyone who needs a stable walking surface. A change in texture between the pathway(s) to the table area is an important cue for those who are blind or have vision loss.

Tables that have the support leg(s) that are not a tripping hazard and do not block the necessary toe and knee space are important.

Application

This section applies to newly constructed and redeveloped outdoor public use eating areas at public facilities which typically provide tables (e.g. picnic tables) intended for public use as a place to consume food.

6.12.1 Design and Layout

- a. ensure a minimum of twenty percent (20%) of tables and no fewer than one in outdoor public use eating area are accessible;
- b. provide a clear space of 2000 mm (minimum) on all sides of the table (Figure 108);
- c. ensure accessible tables provide suitable knee and toe clearances (Figure 109);
- d. ensure 730 – 865 mm high table height;
- e. locate on an accessible path of travel or trail;
- f. ensure ground surface leading to and under tables is firm, stable and no steeper than 1:50 (2%);
- g. tables to be colour contrasted to background;
- h. disperse the locations of accessible tables in outdoor public use eating areas to provide a choice for users with disabilities;
- i. recommend fixing accessible tables and seating so that they cannot be moved to an inaccessible location;
- j. provide directional signage at strategic locations to identify the location(s) of accessible tables and for public use eating areas; and
- k. where washrooms are provided, ensure accessible features (e.g. at least one universal toilet room, per cluster of regular washrooms).

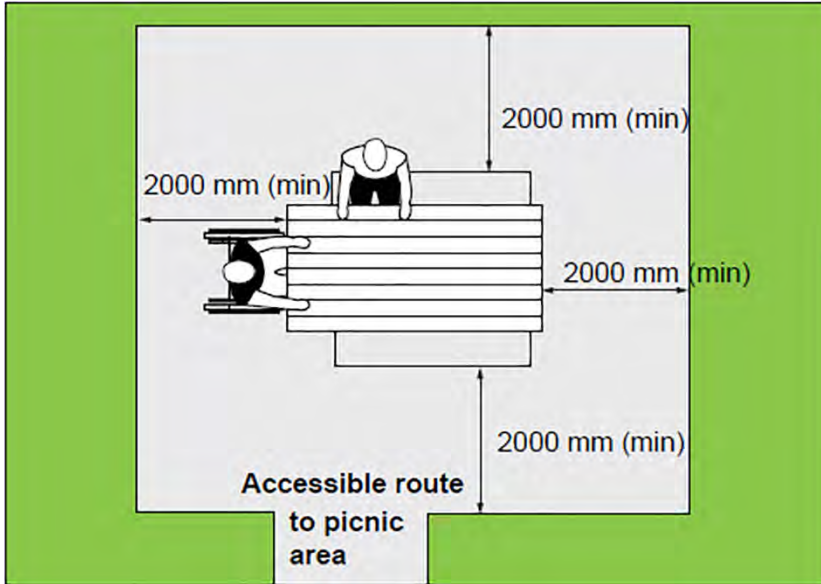

Figure 108: Picnic Table Design and Features - Plan View

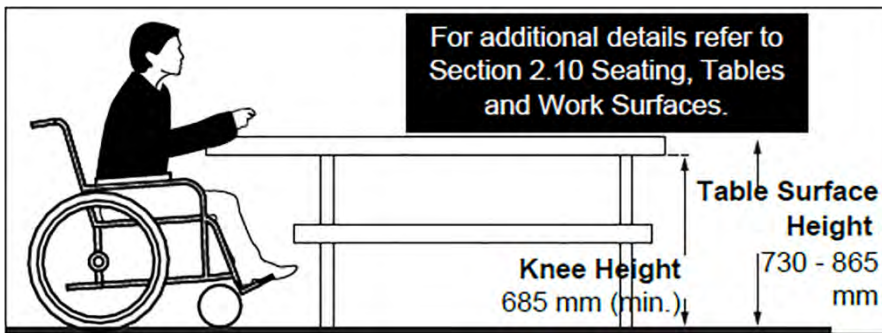

Figure 109: Picnic Table Design and Features - Elevation View

Durham Accessibility and Inclusivity Requirements

April 8, 2022

6.13 Inclusive Play Spaces

Rationale

Inclusive play spaces ensure that children with disabilities have equal opportunities for fun, exercise, peer interaction and development of socialization skills. They also provide \ opportunities for parents and caregivers with disabilities to interact with their children.

Application

This section applies to play spaces designed for children. Play spaces can be located in a variety of public settings (e.g. parks, schools, childcare facilities or community / recreation centres). Play spaces typically require consideration or accessibility features related to:

- the number and types of play structures, equipment, elements and features provided;
- play areas surrounding the play structures; and
- site amenities and features surrounding the play space.

Criteria provided in this section is intended to summarize key features for inclusive play spaces and reference to applicable standards. Detailed planning and design is required for provision of inclusive play spaces.

6.13.1 Consultation Requirements

When constructing new or redeveloping existing outdoor play spaces, consultation on the needs of children and caregivers with various disabilities must occur with:

- a. the public and people with disabilities; and
- b. the Durham Accessibility Advisory Committee.

6.13.2 Design Requirements

When constructing new or redeveloping existing play spaces:

- a. incorporate accessibility features such as sensory and active play components for children and caregivers with various disabilities into the design of outdoor play spaces; and
- b. ensure that outdoor play spaces have ground surface that is firm, stable and has impact attenuating properties for injury prevention and sufficient clearance to provide children and caregivers with various disabilities the ability to move through, in and around the outdoor play space.

Ensure the design of inclusive play spaces and features meet the requirements of CAN / C.S.A. Z614-14, Annex H as amended, including:

- i. H.1 Scope;
- ii. H.2 Reference Publications
- iii. H.3 Reference Definition
- iv. H.4 Play spaces (e.g. ground-level and elevated play components, accessible routes, transfer systems, play components and ground surfaces); and
- v. other applicable sections of these Requirements, as required.

Requirements related to the area surrounding or beyond the play space, including, but not limited to, parking lots, washrooms, drinking fountains, and recreation facilities, are referenced elsewhere in this document.

6.13.3 Summary of Key Design Considerations

The information in the following sub-sections is intended to highlight key considerations only, not detailed specifications. Refer to requirements of the Canadian Standards Association (CAN / C.S.A. Z614-14, Annex H), as amended. This information is not intended to duplicate existing standards, but is focused on presenting best practices for accessibility.

6.13.4 Entry and Exit Points

A level approach, gradually sloped route or ramps are examples of types of accessible entry / exit points to a play space.

Durham Accessibility and Inclusivity Requirements

April 8, 2022

Provide a minimum of two accessible entry / exit points:

- a. located as part of an adjacent accessible route;
- b. ensure accessible connections provided to play space surfaces are firm, stable and slip-resistant, as well as providing direct connections to individual play components; and
- c. provide clear width of 1800 mm.

6.13.5 Accessible Routes

- a. provide at least one accessible route within the boundary of the play space, connecting ground-level play components and elevated play components, including entry and exit points of the play components;
- b. ensure clear width of accessible route is 1800 mm; and
- c. ensure the maximum slope for an accessible route connecting ground-level play components within the boundary of a play space is 1:15 (6.67%).

Refer to exceptions and detailed requirements, including gradient, clear width and reduced width criteria, identified in C.S.A., Annex H, as amended.

6.13.6 Play Space Ground Surface

- a. provide accessible surface materials for play spaces such as poured-in-place rubber, accessible turf, rubber mats and tiles, bond fibres or shredded rubber and engineered wood fibre.

6.13.7 Play Components

- a. provide a high tonal contrast between a play component and its surroundings.

6.13.8 Elevated Play Components

An elevated play component is a play component reached from above or below grade, and is part of a composite play structure.

- a. ensure at least 50% of elevated play components are connected to a ramp or transfer system, as identified in Table 13.

Table 13: Percentage of Elevated Play Components Required to be Connected to Transfer Systems

| Total Number of Elevated Play Components | Total Percentage of Elevated Play Components Requiring Ramp or Transfer System |
|------------------------------------------|--------------------------------------------------------------------------------|
| 20 or more | 50% minimum (25% ramp and 25% ramp or transfer system) |
| Less than 20 | 50% minimum (ramp or transfer system) |

6.13.9 Transfer Systems

A transfer platform is used where transfer is intended from a wheelchair or other mobility aid.

- a. provide transfer systems to connect elevated or ground-level play components (e.g. transfer steps or platforms);
- b. ensure transfer steps are used where movement is intended from a transfer platform to a level that provides elevated play components on an accessible route;
- c. ensure the distance covered by transfer steps is shortest possible; and
- d. provide a minimum clear floor space of 915 mm wide by 1370 mm long or 915 mm by 1525 mm for side approach adjacent to all transfer locations or to play components (Figure 110).

Refer to detailed requirements, including means of support and surface sizes for example, identified in C.S.A., Annex H, as amended. Examples of supports include a rope loop, a loop-type handle, a slot in the edge of a flat horizontal or vertical member, poles or bars, or solid D-shaped rings affixed to corner posts.

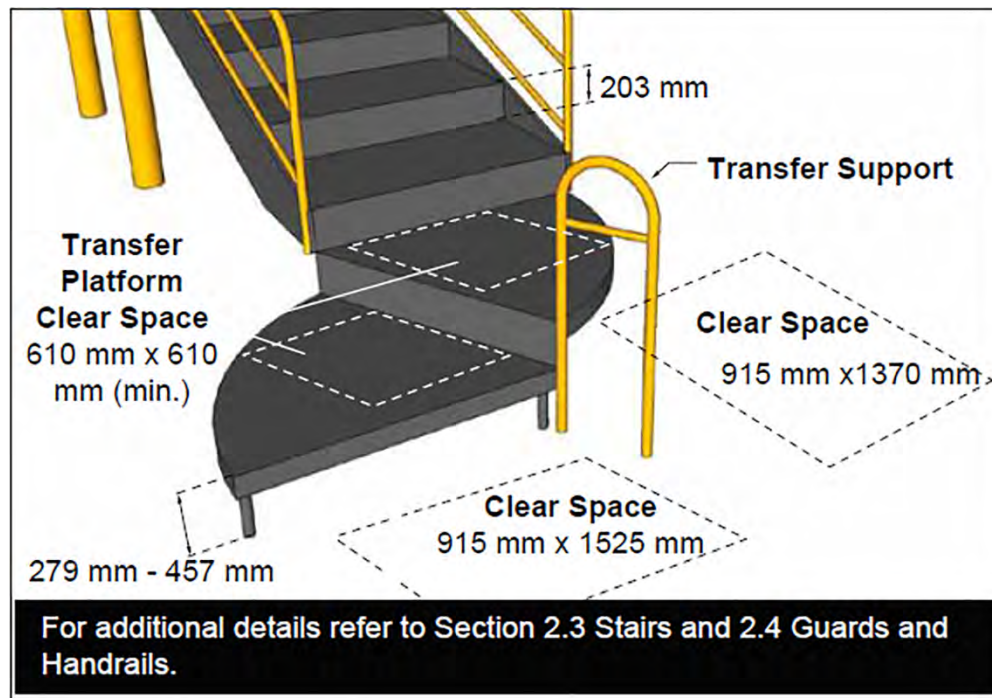

Figure 110: Transfer Systems

6.13.10 Turning Space

provide clear turning space for mobility aids of 1675 mm (preferred) or 1500 mm (minimum) diameter on the same level as play components.

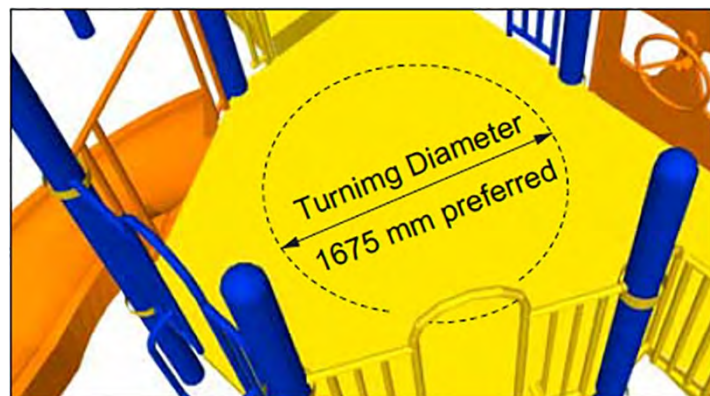

Figure 111: Turning Space - Plan View

6.13.11 Ground-Level Play Components

A ground-level play component is a play component that is approached and exited at the ground level. Provide the ratio of ground-level play component alternatives, compared to elevated play components, as identified in Table 14.

Durham Accessibility and Inclusivity Requirements

April 8, 2022

Table 14: Ground-Level Play Component Alternatives to Elevated Play Components

| Number of Elevated Play Components provided | Minimum number of ground-level play components required to be on an accessible route | Minimum number of different types of ground-level play components required to be on accessible route |
|---------------------------------------------|--------------------------------------------------------------------------------------|------------------------------------------------------------------------------------------------------|
| 1 | n/a | n/a |
| 2 to 4 | 1 | 1 |
| 5 to 7 | 2 | 2 |
| 8 to 10 | 3 | 3 |
| 11 to 13 | 4 | 3 |
| 14 to 16 | 5 | 3 |
| 17 to 19 | 6 | 3 |
| 20 to 22 | 7 | 4 |
| 23 to 25 | 8 | 4 |
| More than 25 | 8 plus 1 for each additional 3 over 25, or fraction thereof | 5 |

Source: Canadian Standards Association (CAN / CSA Z614-14, Annex H)

6.14 Multi-Faith Rooms

Rationale

Multi-faith rooms promote the spiritual well-being of the users of the facilities, by providing a private space that can be used for quiet activity and contemplation by all religions, races, cultures and beliefs. An accessible multi-faith room or space allows individuals of all abilities the opportunity to undertake their own spiritual or cultural practices when required.

Application

This section applies to multi-faith rooms designed for public and staff.

6.14.1 Design and Layout

- a. Multi-faith rooms shall be located on an accessible route, with an accessible entrance.
- b. An accessible path of travel shall be provided within the multi-faith room to all accessible fixtures and furniture.
- c. Provide an accessible storage area for shoes at the entrance of the multi-faith room. A clear area shall be provided at the entrance to the multi-faith room to prevent shoes from blocking the accessible path. This shall be complemented with a KEEP CLEAR mat if the clear entrance is not guaranteed.
- d. Seats are to be provided at entrances and at other locations where people are required to remove their shoes.
- e. Where carpeting is provided within the space, it shall have low pile, be securely fixed to the floor, and comply with the requirements of Section 2.1 Ground and Floor Surfaces.
- f. Accessible seating that complies with Section 2.10 Seating, Tables and Work Surfaces shall be provided within the prayer hall to accommodate people who cannot bend to pray.
- g. Accessible cabinets shall be provided for the storage of religious items and artifacts within the multi-faith room.

6.14.2 Ablution Rooms

- a. Ablution rooms are to be included where multi-faith rooms are provided in a facility. The ablution rooms allow users the proper facilities for ritual cleansing prior to prayer.
- b. Ablution rooms shall be located adjacent to and with direct access to the multi-faith room.
- c. At least 1 ablution station shall be designed to be accessible, with the following requirements:
 - i. Linked to an accessible path of travel, and located closest to the entrance;
 - ii. Electronic or sensor faucets;

Durham Accessibility and Inclusivity Requirements

April 8, 2022

- iii. Two horizontal bars, one on either side of the sink, mounted at a height between 700 – 800 mm, with a support length equal to the length of the sink;
- iv. A bidet shower system, soap and paper dispensers mounted near the sink with all accessories, including the bidet shower mounted at a height between 700 – 1200 mm; and,
- v. clear floor space of 915 mm wide by 1370 mm deep (minimum) for forward approach in front of the station.

6.14.3 Indoor Smudging

The provision of smudging facilities within a building contributes to an inclusive environment for all users for whom this practice is used for cultural and religious purposes. Smudging is used for a variety of purposes, from cleansing to healing to prayer and more. Smudging will typically be conducted within a multi-faith room, unless a dedicated smudging space is provided, or permission and provisions are made for alternate locations.

In spaces where indoor smudging is typically to be practiced;

- a. Suitable exhaust fans and ventilation systems must be in place and operational;
- b. A cast iron (or other suitable material) pan or vessel is to be provided and used for all smudging materials;
- c. The exhaust fan must be turned on prior to the smudging, and is to be left on when exiting the room.

Durham Accessibility and Inclusivity Requirements

April 8, 2022

7.0 Appendices

7.1 Glossary

| Term | Definition |
|------------------|----------------------------------------------------------------------------------------------------------------------------------------------------------------------------------------------------------------------------------------------------------------------------------------------------------------------------------------------------------------------------------------------------------------------------------------------------------------------------------------------------------------------------------------------------------------------------------------------------------------------------------------------------------------------------------------------------------------------------------------------------------------------------------------------------------------------------------------------------------------------|
| Access Aisle | Refers to an accessible and safe pedestrian space or route used for loading and unloading from vehicle, as well as safe travel to and from designated accessible parking spaces to nearest accessible route / entrance. Access aisles include pavement markings for easy identification and are often shared between accessible parking spaces. |
| Accessible | Refers to any space, feature, element, site, environment or facility that can be used (e.g., located, approached, entered, exited or operated) by people with varying disabilities, with or without the use of mobility aids or assistive devices. Can also refer to services, practices and programs. |
| Accessible Route | A continuous, unobstructed path (interior or exterior) connecting users to accessible elements, features, amenities and spaces. Typically, accessible routes include parking access aisles, pedestrian sidewalks and curb ramps and interior corridors, floors, elevators and ramps |
| Accommodation | A term used to reflect how an individual's needs are met for unique circumstances where a solution may not be "technically" feasible or practical to implement. Where barriers continue to exist because it is impossible to remove those barriers at a given point in time, then accommodation should be provided to the extent possible, short of "undue hardship". There is no set formula for accommodating people with disabilities. Each person's needs are unique and must be considered afresh when an accommodation request is made. A solution may meet one person's requirements but not another's, although it is also the case that many accommodations will benefit large numbers of people with disabilities. Accommodating an individual's needs through differential treatment must be achieved in a manner that maximizes integration and dignity. |
| Adaptable | The ability of a certain building space or element, such as kitchen counters, sinks, or grab bars, to be added or altered so as to accommodate the needs of individuals with or without disabilities or to accommodate the needs of people with different types or degrees of disabilities. |
| Ambient Light | The total amount of light in a space, including daylight or artificial light, whether from direct sources or reflected from surfaces in that space |
| Amenities | Features or services that are usable by the public that typically increase physical comfort throughout the built environment (e.g., washrooms, resting areas, telephones, drinking fountains or food vending machines). |
| Amenities | Features or services that are usable by the public that typically increase physical comfort throughout the built environment (e.g., washrooms, resting areas, telephones, drinking fountains or food vending machines). |

Durham Accessibility and Inclusivity Requirements

April 8, 2022

| Term | Definition |
|---------------------------------------|--------------------------------------------------------------------------------------------------------------------------------------------------------------------------------------------------------------------------------------------------------------------------------------------------------------------------------------------------------------------------------------------------------------------------------------------------------------------------------------------------------------------------------------------------------------------------------------------------------------------------------------------------------|
| Amenity Strip | A section of a path or sidewalk that is set aside for placement of street furniture (e.g., benches, hydro poles, vending machines and post boxes), to ensure it is located away from pedestrian path of travel. |
| Anthropometrics | Refers to the study of human physical measurement, movement and proportions of the human body, with respect to reach ranges, sight lines, etc. |
| Area of Refuge (or Rescue Assistance) | A safe holding area which has been designated in a Fire Safety Plan, with direct access to an exit and is equipped with separate ventilation and communication equipment. It is a place where people can wait temporarily until they can exit safely or await further instructions or assistance during an emergency evacuation. |
| Arena | Refers to an enclosed, indoor venue, often circular or oval-shaped and designed to showcase a variety of performance or sporting events (e.g., hockey, basketball, football or soccer) in a large open space, typically surrounded on most or all sides by tiered seating for spectators. Often, the key feature of an arena is that the event space is the lowest point, allowing for maximum visibility. |
| Assembly Area | A room or space accommodating a group of individuals for educational, recreational, political, social, civic or amusement purposes, or for the consumption of food and drink. |
| Assistive Listening Systems (ALS) | Assistive listening systems (ALS) augment standard public address and audio systems by providing signals which can be received directly by people with special receivers or their own hearing aids and which eliminate or filter background noise. The type of assistive listening system appropriate for a particular application depends on the characteristics of the setting, the nature of the program, and the intended audience. Magnetic induction loops, infrared and radio frequency systems are types of listening systems which are appropriate for various applications. Refer to Induction Loop or Infrared Assistive Listening Systems. |
| Audible Signals | Signals which emit a distinctive sound, communication or alert to provide a warning or indicate a readiness to respond (e.g., alarm bell or signal). |
| Automatic Door | A door equipped with electronic sensors allowing it to be opened and triggered when pedestrians approach (e.g., typically sliding doors or swing doors equipped with guardrails for safety). See Power-Assisted Door. |
| Barrier | Refers to anything that prevents a person with a disability from fully participating in any aspect of society because of their disability. This can include a physical barrier, an architectural barrier, an information or communication barrier, an attitudinal barrier, or a technological barrier for example. It can also include policies and practices that result in an obstacle or hardship (e.g., systemic barrier). |
| Blended Curb | A connection with a slope of 1:20 (5%) or less between the level of a pedestrian walkway and the level of a crosswalk. |
| Bollard | Typically a 900 mm high (minimum) post to mark a pedestrian path from vehicular traffic. |

Durham Accessibility and Inclusivity Requirements

April 8, 2022

| Term | Definition |
|-----------------------------------|--------------------------------------------------------------------------------------------------------------------------------------------------------------------------------------------------------------------------------------------------------------------------------------------------------------------------------------------------------------------------------------------------------------------------------------------------------------------------------------------------------------|
| Braille | Braille is a system of touch reading for the blind which employs embossed dots evenly arranged to represent numbers and letters. Literary Braille, as officially approved, comprises of two grades. Grade 1 Braille is in full spelling and consists of the letters of the alphabet, punctuation, numbers, and a number of composition signs which are special to Braille. Grade 2 Braille consists of Grade 1 and 189 contractions and short-form words, typically used for signage where space is limited. |
| Change Room | See Dressing Room. |
| Circulation Route or Path | An exterior or interior pedestrian way used for traveling from one place to another. |
| Clear Floor Space | The amount of unobstructed floor or ground space required to accommodate a single stationary user, or a mobility device / aid, such as wheelchairs, scooters, canes and crutches. |
| Closed Circuit | A telephone with dedicated line(s), such as a house phone, courtesy phone or phone that must be used to gain entrance to a building or part thereof. |
| Closer | See Door Closer |
| Common Use | Refers to those interior and exterior rooms, spaces or elements that are made available for regular and daily for use by the occupants or visitors of a facility. (e.g., common use areas of an office may include kitchens, reception areas, washrooms, etc.). |
| Communication Devices and Systems | Devices that enable or enhance the ability of people to receive or transmit information, usually electronically, for communication. |
| Cross-Slope | The slope that is perpendicular to the direction of travel. Opposite of running slope. |
| Crosswalk | That part of a roadway at an intersection that is marked for safe pedestrian crossing (e.g., by lines or other markings on the surface). |
| Curb Ramp | A sloped ramp surface cutting through a curb or built up to it (e.g., between the sidewalk and the road surface). |
| DAIR | Refer to Stage. |
| Deaf | A term to describe people with a severe to profound hearing loss (90 decibels or greater), with little or no residual hearing. Lowercase deaf is used when referring to the medical / audio logical condition of having little or no hearing, while uppercase Deaf refers to individuals who identify themselves as deaf and share a culture and community, not just a medical condition. |
| Deafened | A term used to describe individuals who grow up hearing or hard of hearing and suddenly, or gradually, experience a profound loss of hearing. Late-deafened adults usually cannot understand speech without visual clues such as print interpretation (e.g., computerized note taking), speech reading or Sign Language. |
| Disability | Describes a functional limitation or activity restriction caused by an impairment. Common types include: sensory (e.g., vision or hearing), mobility, physical, cognitive, learning or mental health disabilities. Refer to the Ontario Human Rights Code for a detailed definition of disabilities |
| Door Closer | A device or assembly used to open or close a door automatically. |

Durham Accessibility and Inclusivity Requirements

April 8, 2022

| Term | Definition |
|-------------------------------|-----------------------------------------------------------------------------------------------------------------------------------------------------------------------------------------------------------------------------------------------------------------------------------------------------------------------------------------------------------------------------------------------------------------------------------------------------------------------------|
| Door Jamb | The vertical component of a door frame. |
| Dressing Room | Home or visiting team locker rooms that are not for the general public, but dedicated to the group using the playing areas (e.g., hockey arena, soccer field or basketball court). Generally contains showers, benches and washroom amenities. |
| Egress (Means of) | Means of egress refers to a continuous path of travel provided for the escape of people from any point in a building leading to a point of safety (e.g., a separate building or an exterior open space protected from fire exposure), including exits and exit routes. |
| Elevator Lobby | The waiting area in front of an elevator. |
| Entrance | An access point into a building or portion of a building or facility used for the purpose of entering. An entrance includes the approach, the vertical access leading to the entrance platform, the entrance door, landing area, vestibules (if provided), the entry door or gate, and the hardware of the entry door or gate. The principal or main entrance of a building or facility is the door through which most people typically enter (e.g., highest level of use). |
| Exit | The part of a means of egress, including doorways, that leads from the floor area it serves to a separate building, an open public thoroughfare, or an exterior open space protected from fire exposure from the building and having access to an open public thoroughfare. |
| Facility | All or any portion of buildings, structures, elements, improvements, equipment and pedestrian or vehicular routes located on a site or in a public right-of-way, where specific programs or services are provided or activities performed. |
| Fire Safety | A general term typically relating to the ability of a building or site to resist, suppress or control the onset and spread of fire and the protection of building occupants. |
| Fire Safety Plan | An operational plan that provides information, directions, strategies and recommendations for the safe evacuation of users during fire emergencies |
| Firm Surface | Refers to a surface that does not deform under the vertical forces exerted by permitted users. Reference ASTM F 1951 Standard. |
| Flare Sides | A sloped surface that flanks a curb ramp and provides a graded transition between the ramp and the sidewalk. Flares bridge differences in elevation and are intended to prevent ambulatory pedestrians from tripping. Flares are not considered part of the accessible route. |
| FM Assistive Listening System | FM assistive listening systems are variations on the commercial FM radio. Radio signals are broadcast by an FM transmitter that is piggybacked on the sound system used in the facility. These signals are received by individual "radios", which are small pocket-size receivers tuned to the specific frequency used in the transmission. |

Durham Accessibility and Inclusivity Requirements

April 8, 2022

| Term | Definition |
|-------------------------------------------|---------------------------------------------------------------------------------------------------------------------------------------------------------------------------------------------------------------------------------------------------------------------------------------------------------------------------------------------------------------------------------------------------------------------------------------------------------------------------------------------------------------------------------------------------|
| Foot-Candle (FC) | Refer to measurements of the visible light intensity on a surface, a distance from the light source. One foot-candle is equivalent to the illumination produced by one candle (an optical standard reference) at a distance of 305 mm (one foot). One foot-candle equals approximately ten lux. Foot-candle is the imperial measure. Refer to Lux. |
| Forward Approach | Where a person will make use of a service counter, drinking fountain, or any other usable element of the built environment, by positioning their body or mobility aid directly in front of and facing the element. |
| Glare | Often refers to uncomfortably bright light reflected from a surface, floor, window or screen. Glare occurs when one part of the environment is much brighter than the general surrounding area, causing annoyance, discomfort or loss in visual performance. |
| Grade | The slope parallel to the direction of travel that is calculated by dividing the vertical change in elevation by the horizontal distance covered. |
| Guard | Protective barrier to prevent accidental falls at openings in floors and at the open sides of stairs, landings, balconies, mezzanines and ramps. Handrail supports often act as guards. |
| Hard of Hearing | A term used to describe people with a hearing loss who rely on residual hearing to communicate through speaking and speech-reading, as well as to hold conversations on the telephone. The degree of hearing loss can range from mild to profound. People who are hard of hearing can understand some speech sounds, with or without a hearing aid, and communicate primarily by speech. people who are hard of hearing often use hearing aids, lip reading and other assistive technologies. |
| High Tonal Contrast | Tonal contrast refers to the difference in colour and brightness between one surface or element and its adjacent surface. Effective tonal contrast can be used to locate a particular feature, for example using a different colour and / or brightness for a handrail compared to the surface around the handrail. |
| Illumination | The combined amount and intensity of lighting provided, measured in foot-candles or lux. |
| Kilonewton (kN) | Equals 1000 Newtons. |
| Induction Loop Assistive Listening System | Induction loop assistive listening systems use a wire around the room to transmit an electromagnetic signal that is picked up by a small telecoil in the hearing aid. Users simply switch on this telecoil (the "T" setting) and adjust the volume of the hearing aid, if necessary. Loop systems are generally used by fewer people with hearing loss due to advances in hearing aid technology. |
| Infrared Assistive Listening System | Infrared assistive listening systems operate on infrared light that is beamed from one or several infrared transmitters to small, specialized receivers. There are several types of infrared receivers: stethoscope-style that dangle from the ears, a headset type that fits over the ears, and a small pocket-size type similar to the FM receiver. Where confidential transmission is essential (e.g., a court room setting), an infrared system generally is more effective recognizing transmission will be restricted within a given space. |
| Lavatory | A washbasin or sink used for personal hygiene. |

Durham Accessibility and Inclusivity Requirements

April 8, 2022

| Term | Definition |
|-----------------------------------|--------------------------------------------------------------------------------------------------------------------------------------------------------------------------------------------------------------------------------------------------------------------------------------------|
| Lux | The metric measurement for light intensity or illumination. See Foot-Candle. |
| Maneuvering Space | The minimum floor or ground area needed for users of mobility aids to move into or out of a place, space or along an accessible pathway or route. |
| Mobility Aids (or Devices) | A term used to encompass the variety of assistive devices used by people with mobility / physical types of disabilities, including manual and power wheelchairs, scooters, canes and crutches. |
| Newtons (N) | The amount of force needed to move 1 kilogram of an object 1 meter per second squared. |
| Operable Control | The part of equipment or appliances that is used to insert or withdraw objects, to activate or deactivate, or to adjust the equipment or appliance (e.g., a coin slot, pushbutton or handle). |
| Operable Portion | A part of a piece of equipment or appliance, used to insert or withdraw objects or to activate, deactivate or adjust the equipment or appliance, such as a coin slot, push button or handle. |
| Passenger Loading Zone | Designated and signed area used for loading and unloading of passengers into or out of a waiting vehicle. |
| Pedestrian Access Route | An accessible route or corridor for pedestrian use within the public right-of-way. |
| Pictogram | A pictorial symbol or image that represents activities, facilities, spaces or concepts. |
| Platform Lift | An elevating device which is used to transport a person (with or without assistive equipment) between levels on a platform. A vertical platform lift is a self-contained unit, with or without an enclosure. An inclined platform lift is used for staircases. |
| Power-Assisted Door | A door with a mechanism that opens the door automatically, upon the activation of a switch, button or a control. The door also remains in the "open" position for a set period of time to allow safe passage. See Automatic Door. |
| Public Entrance | An entrance that is not a service entrance or a restricted entrance. |
| Public Use | Buildings, facilities and interior or exterior rooms, spaces, sites or elements that are made available to the public and that are typically owned, operated or leased by the City of Oshawa. |
| Ramp | A walking surface with a running slope steeper than 1:20 (5%). |
| Running Slope | The slope that is parallel to the direction of travel expressed as a ratio of rise to run. Opposite of cross-slope. |
| Seated Mobility Assistance Device | A term used to encompass the variety of assistive devices that users will be seated upon to move about a space. Used by people with mobility / physical types of disabilities, including manual and power wheelchairs and scooters. Refer also to Mobility Aids (or Devices) |
| Service Counter | A raised surface on which business is transacted. Service counters can be comprised of either built-in (e.g., kiosks) or loose furniture (e.g., podiums). Other examples of service counters include: ATMs, checkout counters, self service kiosks, food vendor, and information counters. |
| Service Entrance | An entrance not intended for use by the public and used primarily for delivery of goods and services. |

Durham Accessibility and Inclusivity Requirements

April 8, 2022

| Term | Definition |
|------------------------------------------|------------------------------------------------------------------------------------------------------------------------------------------------------------------------------------------------------------------------------------------------------------------------------------------------------------------------------------------------------------------------------------------------------------------------------------|
| Side Approach | Where a person will make use of a service counter, drinking fountain, or any other usable element of the built environment, by positioning their body or mobility aid perpendicular to the element. |
| Sidewalk | A public right-of-way designated for pedestrian use and typically located between the curb or roadway and the adjacent property line. |
| Sightline | The line of view between a person in an audience and a performance, speaker or displayed item. |
| Sign or Signage | A sign is a means of conveying information about direction, location, safety or form of action and in general should be designed to be clear, concise and consistent. Signage displays text, symbols, tactile or pictorial information. |
| Site | A parcel of land bounded by a property line or a designated portion of a public right-of-way. |
| Slip-Resistant | A surface that provides sufficient frictional counterforce to the forces exerted in walking to permit safe ambulation. |
| Sprinklered | Refers to a building or any part of a building equipped with an automatic sprinkler system. |
| Stable Surface | Refers to a surface that does not deform or erode under the angular forces of permitted users travelling in a straight line or turning. |
| Stage | Refers to a space designed primarily for performances and is typically elevated from the audience seating area. |
| Stair System | Refers to combined elements that make up a typical stair, including steps, landings, and handrails, for example. |
| Street Furniture | Elements in the public right-of-way that are intended for use by pedestrians, including benches, lighting fixtures, waste dispensers and paper vending machines, for example. |
| Tactile | Describes an object that can be perceived using the sense of touch, and typically provided for users with vision loss. |
| Tactile Walking Surface Indicator (TWSI) | A surface detectable underfoot or by a long white cane, to assist people with low vision or blindness by alerting or guiding them. |
| Touch Tour | Typically refers to tours provided by museums or other cultural / arts facilities that allow users with vision loss to touch and feel objects, displays and features, for example to gain a sensory understanding of objects and allow individual exploration. Tactile experiences may include: replicas, models, props, and handling objects which convey one aspect of the work. |
| Transfer Space | An unobstructed area adjacent to a fixture or furniture, allowing the positioning of a mobility aid to assist users with transferring to the fixture or furniture. |
| TTY, Teletypewriter or Text Telephone | TTY is the abbreviation for "teletypewriter" and refers to a means of electronic communication between deaf people or deaf and hearing people using interactive, text-based communication. Used in conjunction with a telephone, this device transmits and received typewritten messages using coded signals across the standard telephone network. The term T.T.Y. also refers to devices known as "text telephones" and T.D.D.s. |

Durham Accessibility and Inclusivity Requirements

April 8, 2022

| Term | Definition |
|------------------------------------------------|-------------------------------------------------------------------------------------------------------------------------------------------------------------------------------------------------------------------------------------------------------------------------------------------------------------------------------------------------------------------------------------------------------------------------------------------------------------------------------------------------------------------------------------------------------------------------------------------------------------------------------------------------------------------------------------------|
| Universal Access | A broad term to reflect the intended goal of inclusion for all, based on the principles of universal design or the “design of products and environments to be usable by all people, to the greatest extent possible, without the need for adaptation or specialized design” (Ron Mace). |
| Universal Trail Assessment Process or U.T.A.P. | "An objective method of documenting trail conditions for universal access. The UTAP: <ul style="list-style-type: none"> - documents actual trail conditions; - enhances user safety through accurate information about trail conditions; - increases access for people of all abilities; - identifies maintenance needs- creates accessibility information; - enhances environmental protection; - facilitates trail planning and budgeting; - enables informed choice of trails based on interests and abilities; - inventories trails and facilities; and - documents patterns of trail use." |
| Video Signage | Video signage refers to video devices such as televisions, computer monitors / screens, and flat panel displays that may be used to provide information (e.g., directories). Advantages of video signs include the use of motion to attract attention, and the ability to rapidly update the content of the signs. |
| Vision Loss | This term usually refers to a progressive decrease in visual acuity. However, it can refer to the sudden onset of substantial acuity decrease or total blindness. |
| Vision Panel | A glazed opening in a door leaf which allows people to see through to the other side without opening the door. |
| Visitable Housing | Visitable housing is the concept of designing and building homes with basic accessibility, providing easy access on the main level for both residents and visitors of all ages and abilities. The three basic accessibility features include no step entry, clear passageways, and an accessible washroom. |
| Wayfinding | A term used to describe a variety of means for spatial orientation and finding your way to a destination. Wayfinding design describes a variety of means for helping people find their way, through touch, print, signage, architecture and landscaping, for example. |

