

**CURB DETAIL**

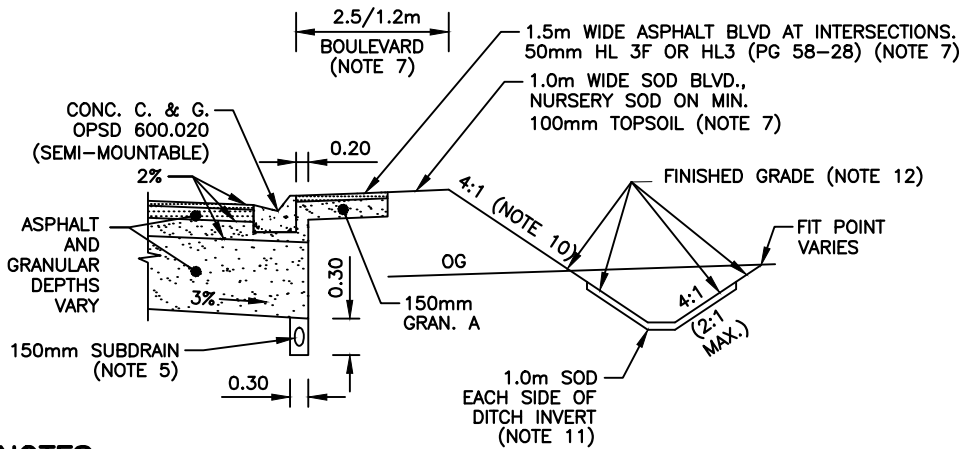

**SUBDRAIN DETAIL WHERE APPLICABLE**

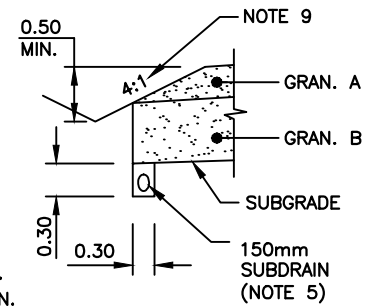

**NOTES:**

- FOR SHOULDER WIDTH REFER TO ROADS AND ENTRANCEWAY SPECIFICATIONS
- FOR SUPERELEVATED ROADS REFER TO OPSD 210.020, 206.020 AND S-300.062
- AT GUIDE RAIL LOCATIONS, ROUNDING TO BE 1.0m FOR OPSD 912.185 INSTALLATIONS AND 0.5m FOR OPSD 912.186 INSTALLATIONS. IN ADDITION REFER TO OPSD 202.031, 202.032 (FOR GRADING END TREATMENTS).
- FULL WIDTH PAVED SHOULDERS OR PARTIAL WIDTH PAVED SHOULDERS AS PER S-300.060.
- SUBDRAIN TO BE OPEN PROFILE (DUAL WALL) HDPE PIPE. CONNECT PERFORATED SUBDRAIN TO NON PERFORATED C.S.P. (2.0m) OR NON PERFORATED OPEN PROFILE (DUAL WALL) HDPE PIPE WHEN OUTFALLING INTO DITCH. RODENT GRATES TO BE PLACED AT OUTFALLS AS PER S-100.090.
- UTILITY CROSSINGS TO HAVE MIN. 0.8m COVER TO BOTTOM OF DITCH. GAS MAINS TO HAVE 1.2m COVER.
- OUTSIDE INTERSECTIONS THE BOULEVARD CAN BE REDUCED TO 1.2m AND PAVED WIDTH REDUCED TO MIN. 0.7m WITH 0.5m SOD.
- SUBDRAIN REQUIRED WHERE BOTTOM OF SUBGRADE TO BOTTOM OF DITCH IS LESS THAN 0.3m.
- 4:1 GRANULAR SIDESLOPES ARE DESIRABLE, 3:1 MAXIMUM.
- THE DESIRABLE EMBANKMENT SIDESLOPE IS 4:1. A 3:1 SIDESLOPE MAY BE USED AT CONSTRAINT LOCATIONS. INCLUDE GUIDERAIL PROTECTION FOR STEEP SIDESLOPES AS SPECIFIED
- PROVIDE SOD WHERE DITCH IS SHALLOW AND SEED/MULCH AREA <0.50m.
- SEED AND MULCH WITH 50mm OF TOPSOIL TO COVER GRANULAR ROAD EMBANKMENT BEYOND ROUNDING. PLACE 100mm OF TOPSOIL (BELOW FINISHED GRADE) BEYOND GRANULAR ROAD EMBANKMENT.
- PROVIDE 0.5m TO 1.0m WIDE FLAT BOTTOM DITCHES WHERE GRADING CAN BE ACCOMMODATED WITHIN R.O.W AND WHEN NOT DIRECTLY IN FRONT OF A RESIDENTIAL HOME OR WITHIN 100m OF THE DITCH HIGH POINT.
- SHOULDER LAYOUT POINT AT MIDDLE OF ROUNDING

ALL DIMENSIONS IN METRES EXCEPT WHERE NOTED.



WORKS DEPARTMENT

**TYPICAL SECTION RURAL**

DWG. DATE: 2010 04
REVISION NO.: 11
REV. DATE: 2023 02
SCALE: N.T.S.

**S-300.020**